

**TOWN OF CONCORD  
SELECT BOARD  
AGENDA  
JUNE 21, 2021  
5:00 PM  
VIDEO CONFERENCE**

Join Zoom Meeting

<https://us02web.zoom.us/j/84092395810?pwd=TnMyWmprWHBla21CczdQM0EvWVVFZz09>

Meeting ID: 840 9239 5810

Passcode: 865209

One tap mobile

+16465588656,,84092395810# US (New York)

Dial by your location

877 853 5257 US Toll-free

888 475 4499 US Toll-free

Meeting ID: 840 9239 5810

Find your local number: <https://us02web.zoom.us/u/kcwFtQro3l>

#	Agenda Item
1.	Call to Order
2.	Welcome new Select Board member Henry Dane
3.	Elect New Select Board Officers
4.	Consent Agenda <ul style="list-style-type: none"> <li>• Town Accountant Warrants: June 10, 2021</li> <li>• Minutes to approve: May 10, 2021; May 17, 2021; May 24, 2021</li> <li>• Gift Acceptance: Friends of Sleepy Hollow gift through donation by Mary McGuire Tyler and Family of \$10,000.00 to the Cemetery Trees Account for the replacement and replanting of trees and/or bushes near the intersection of Ripley and Bartlett Avenues in Sleepy Hollow Cemetery</li> </ul>
5.	Town Manager's Report
6.	Chair's Remarks
7.	Discuss Upcoming Meetings: In-Person, Virtual, Hybrid
8.	Public Hearing: Grant of Location Petition from Comcast to install approximately 262 feet of Coaxial Cable in 3" PVC conduit in Hubbard Street and two new vaults within the sidewalks, in front of #54 and #34 Walden St.
9.	Public Hearing: Petition from National Grid to relay approximately 1850 feet of 2" CS and 60 feet of 2" PL 60 psi gas main with 1960 feet of new 4" PL 60 psi in Hubbard Street, from Thoreau Street to Walden Street.
10.	Debrief from Town Meeting
11.	Confirm Summer Meeting Schedule
12.	Discuss Focused Meetings and Possible Topics
13.	Discuss FY22 Draft Committee Liaison Assignments
14.	Discuss FY21 Select Board Goals and Upcoming FY22 Goal Setting Session
15.	Discuss Process for Town Manager Evaluation
16.	Committee Nominations: Deborah Adelman of 1 Abbot Lane to the Bruce Freeman Rail Trail Advisory Committee for a term to expire on April 30, 2024. Ann Sussman of 534 Old Marlborough Road to the West Concord Advisory Committee for a term to expire on April 30, 2024. Melinda Shumway of 365 Garfield Road to the Historic Districts Commission for a term to expire on January 1, 2026.

17.	Committee Appointments: Jack Clymer of 13 River Street to the Tax Relief Committee for a term to expire on April 30, 2024
18.	Committee Liaison Reports
19.	Miscellaneous Correspondence
20.	Public Comments
21.	Adjourn

**TOWN OF CONCORD  
SELECT BOARD  
MAY 10 2021  
MINUTES**

Pursuant to notice duly filed with the Town Clerk, the Concord Select Board convened in a meeting via video conference on May 10, 2021 at 4:00pm.

Present were Linda Escobedo, Chair; Susan Bates, Clerk; Jane Hotchkiss, Terri Ackerman, and Matthew Johnson. Also present was Stephen Crane, Town Manager.

**Call to Order**

**Roll call vote**

Ms. Escobedo: Present  
Ms. Bates: Present  
Ms. Ackerman: Present  
Ms. Hotchkiss: Present  
Mr. Johnson: Present

**Consent Agenda**

- Minutes to approve: April 5, 2021; April 12, 2021; April 12, 2021 Executive Session (not to be released)

Upon a motion duly made and seconded, it was **UNANIMOUSLY VOTED:** to approve the consent agenda.

**Roll call vote**

Ms. Escobedo: Aye  
Ms. Bates: Aye  
Ms. Ackerman: Aye  
Ms. Hotchkiss: Aye  
Mr. Johnson: Aye

**Town Manager's Report**

Governor Baker recently announced that four mass vaccinations sites would be closing by the end of June and that vaccination efforts would be focused at the regional level in partnership with local boards of health. The regional vaccination clinic that was submitted by a nine-town collaborative, including Concord, is still pending before the Massachusetts Department of Public Health (DPH). It is unclear if that application will be approved but Health Director Susan Rask has contacted DPH to reiterate our commitment to the regional clinic.

The Concord Police Department participated in a bicycle rodeo for children on Saturday, May 1, at Cousins Field, and featured a variety of activities and courses that children, parents and officers took part in together. Children won prizes, including backpacks and reflective stripes.

**TOWN OF CONCORD  
SELECT BOARD  
MAY 10 2021  
MINUTES**

Officer Anthony Salvucci, Detective Tia Manchuso and Inspector Ronald Holsinger were on hand to help participants of all ages learn new skills — including the rules of the road — in order to help children safely ride their bikes to school. The event was held ahead of National Walk, Bike and Roll to School Day on Wednesday, May 5, which was celebrated with support from Concord Police, the Concord Public schools, Safe Routes to School and the Transportation Advisory Bicycle Subcommittee, as well as numerous community members, to make the event a success.

In accordance with MassDEP's requirement for all Public Water Systems (PWS) serving between 10,000 and 50,000 customers to begin quarterly sampling for PFAS in the month of April 2021. Division staff completed initial sampling activities on April 12th at all raw and finished groundwater supply sources. Testing was performed under MassDEP's free PFAS Lab Analyses Program for PWS, with the cost for field samples, associated confirmatory samples, and QA/QC data review covered under the program.

Initial results were received in late April, and confirmatory sampling to ensure the validity of initial results was completed in early May. While not final, these initial results demonstrate that all groundwater supplies have levels of PFAS6 below MassDEP's Maximum Contaminant Level (MCL) of 20 parts per trillion (ppt), indicating immediate or emergency treatment for these compounds is not needed at this time. One groundwater supply (Hugh Cargill Wellfield) had an initial result of >10 ppt, and will likely require monthly monitoring going forward. All other groundwater supplies will remain on quarterly monitoring. Notably, there was no detection of PFAS6 at Robinson Well. Messaging is actively being prepared to communicate these results to our customers, including the development of a webpage dedicated to this topic.

The benches at Heywood Meadow will be replaced this week after receiving a facelift from resident Michael Sprague, who sanded the benches and applied marine grade spar varnish to each bench.

The Division of Natural Resources invites all residents to participate in pulling the wildly invasive Garlic Mustard that is currently flowering around Town. The Division of Natural Resources staff will train volunteers on garlic mustard identification and will supply yard waste bags for garlic mustard.

The Fire Department responded to eighty-one calls for service and conducted several fire prevention inspections including a property with two 1,000 gallon underground propane tanks. School fire drills were also conducted at Alcott, Thoreau, Ripley, and Willard. This burn season through Permittees, we have issued over 362 burn permits. We still have 22 Agriculture burn permits active and we have received 280 request and transactions for permits and 26Fs.

Mr. Crane announced that the Town of Concord has once again received an AAA Bond Rating with stable outlook from Moody's. Mr. Crane commended the Chief Financial Officer Kerry Lafleur and her department for their work.

**TOWN OF CONCORD  
SELECT BOARD  
MAY 10 2021  
MINUTES**

**Chair's Remarks**

Ms. Escobedo noted that the League of Women Voters recently held a presentation regarding cyber security led by Chief Information Officer Jason Bulger and the Town Manager. The League of Women Voters also held a presentation on Open Meeting Law from the Assistant Attorney General.

The Select Board sent a letter to the Middle School Building Committee last week to applaud all of the work they have been doing. The Select Board also encouraged them to target, as closely as possible, a one hundred million dollar project, and strongly encouraged them to listen to the significant feedback from the community at this time as they seek compromise before moving into the schematic design phase.

**Concord Library Sustainability Committee Draft Report**

The Library Sustainability Committee has drafted a sustainability plan. Library Corporation Director Sherry Litwack and Library Trustee Jeff Adams presented the report. The plan outlines the necessary steps for assessing, planning, and implementing a series of collaborative actions across operations and programming between 2021 and 2026 and establishes the aspirational goal of carbon neutrality by 2030. The plan builds on the commitment of the Library to meet the needs of today and future generations through stewardship and information sharing. Finally, the plan aligns with the Town of Concord's emissions reduction goals for 2050. This plan supports a ten year roadmap to climate neutrality and sustainability for the CFPL Corporation and its partners. Residents can [view the full plan on the committee's website](#).

Select Board members voiced support for the committee's goals of consistently reassessing needs and feasibility of different sources of energy, new technology, and grant opportunities. The committee acknowledged the rapidly changing energy market and technology landscape, and the need to plan and reassess in short intervals in order to meet the goal of carbon neutrality.

**Update on 2019 Hard Drive Data Breach**

Mr. Crane reiterated that in October 2019, 108 hard drives were inappropriately removed from Concord Public Works, where they were being held in preparation for proper disposal. Concord Police launched an extensive investigation which is ongoing. There has not been definitive proof of a case of identity theft associated with this breach. Under state law, the Town had to notify the population that was impacted by this breach. Part of this process includes offering credit monitoring to the party subjected to the breach. The hard drives were not encrypted, a third party forensic data company searched the devices the drives were taken from to understand who was impacted. A third party call service has been providing credit monitoring to impacted individuals who were notified. Mr. Crane stated that the Town has taken all the steps that need to be taken, and is in the process of summarizing the impact of the data breach and all the steps that have been taken.

**TOWN OF CONCORD  
SELECT BOARD  
MAY 10 2021  
MINUTES**

**Discussion of ATM Warrant Articles Discussed at the May 6 Public Hearing**

#	Article Name	SB Recommendation	Vote
34	Community Preservation Committee Appropriation Recommendations in the amount of \$1,769,891.00	Affirmative Action	Unanimous
27	Minuteman Regional Technical High School District Budget in the amount of \$1,289,284.00.	Affirmative Action	Unanimous
28	Concord Public Schools Budget in the amount of \$41,708,424.00	Affirmative Action	Unanimous
29	Concord Public Schools Capital Budget as written in the warrant.	Affirmative Action	Unanimous
30	Concord-Carlisle Regional High School Budget in the amount of \$24,608,739.00	Affirmative Action	Unanimous

**Assign Select Board Warrant Article Narratives as needed**

Ms. Escobedo stated that it is unlikely there will be a Select Board narrative needed for the Town Meeting materials booklet regarding any of the articles in the previous agenda item. Draft narratives need to be completed by the 19<sup>th</sup> to Ms. Escobedo. These will be discussed on May 24<sup>th</sup>.

**Committee Nominations:**

Chief Financial Officer Kerry Lafleur to the Retirement Board for a term to begin on June 1, 2021, set to expire on April 30, 2024

**Committee Liaison Reports**

Ms. Hotchkiss attended the White Pond Advisory Committee meeting, where Deputy Town Manager Kate Hodges and Town Manager Stephen Crane met with the committee regarding the redevelopment plans for the pond. The Natural Resources Commission met and discussed the wetlands boundaries requirements for different properties.

Ms. Ackerman attended the PEG Access Committee meeting, where they are looking for three new members. The PAAC also voted to support Article 41 for the 2021 Town Meeting. The

**TOWN OF CONCORD  
SELECT BOARD  
MAY 10 2021  
MINUTES**

West Concord Advisory Committee and West Concord Cultural District Committee held a joint meeting where they reviewed the preamble of the West Concord Building Design Guidelines. The West Concord Junction Cultural District Committee is looking for a new member.

Mr. Johnson attended the Middle School Building Committee, where they voted 14-2 to revise the space summary recommendation and move to the schematic design phase. The Housing Authority Board has negotiated a contract with the new Executive Director Jennifer Polito. Town engineers have also completed a proposed site plan for a new house on Commonwealth Avenue and will be submitting a notice of intent to the Natural Resources Commission. The Public Ceremonies and Celebrations Committee is preparing for their Memorial Day celebrations. The MAPC MAGIC group met and discussed the MetroCommon 2050 Plan, with a focus on strategies for developing affordable housing in the region.

Ms. Bates attended the Planning Board meeting, where they had a hearing regarding Concord Children's Center proposal at 250 Old Bedford Road. The hearing will be continued until June 4. On June 22<sup>nd</sup>, there will be a public forum on the MAPC's plan for the Thoreau Business District. The Concord Business Partnership heard a presentation from the Middle School Building Committee. The Cemetery Committee met and discussed the declining population of Blanding's Turtle in Concord. The committee is working with Mass Wildlife to protect the turtles. Ms. Bates announced she will not be stepping up to the role of SB Chair for FY'22 as might be expected as SB tradition for the board's Clerk.

**Miscellaneous Correspondence**

Correspondence was included in the [meeting materials](#).

**Public Comments**

There were no public comments.

**Adjourn**

Upon a motion duly made and seconded, it was UNANIMOUSLY  
**VOTED:** to adjourn.

**Roll call vote**

Ms. Escobedo: Aye  
Ms. Bates: Aye  
Ms. Ackerman: Aye  
Ms. Hotchkiss: Aye  
Mr. Johnson: Aye

TOWN OF CONCORD  
SELECT BOARD  
MAY 10 2021  
MINUTES

Meeting Materials: <https://concordma.gov/DocumentCenter/View/29597/May-10-SB-Packet>

Minuteman Media Network Coverage: <https://www.youtube.com/watch?v=oe2BtHgNfRY>

DRAFT

**TOWN OF CONCORD  
SELECT BOARD  
MAY 17 2021  
MINUTES**

Pursuant to notice duly filed with the Town Clerk, the Concord Select Board convened in a meeting via video conference on May 17, 2021 at 4:00pm.

Present were Linda Escobedo, Chair; Susan Bates, Clerk; Jane Hotchkiss, Terri Ackerman, and Matthew Johnson. Also present was Stephen Crane, Town Manager.

**Call to Order**

**Roll call vote**

Ms. Escobedo: Present  
Ms. Bates: Present  
Ms. Ackerman: Present  
Ms. Hotchkiss: Present  
Mr. Johnson: Present

**Consent Agenda**

- Town Accountant Warrants: May 13, 2021
- National Public Works Week Proclamation: May 16 – May 22, 2021
- One Day Special Liquor Licenses
  - o Verrill Farm 11 Wheeler Road May 17, 2021 5:30pm-7:30pm Wines & Malt Beverages Only
  - o Verrill Farm 11 Wheeler Road June 6, 2021 12:00pm-4:00pm Wines & Malt Beverages Only
  - o Verrill Farm 11 Wheeler Road June 12, 2021 12:00pm-4:00pm Wines & Malt Beverages Only
  - o Verrill Farm 11 Wheeler Road June 24, 2021 5:00pm-9:00pm Wines & Malt Beverages Only
  - o Verrill Farm 11 Wheeler Road August 7, 2021 11:00am-3:00pm Wines & Malt Beverages Only

Upon a motion duly made and seconded, it was UNANIMOUSLY **VOTED:** to approve the consent agenda.

**Roll call vote**

Ms. Escobedo: Aye  
Ms. Bates: Aye  
Ms. Ackerman: Aye  
Ms. Hotchkiss: Aye  
Mr. Johnson: Aye

**Town Manager's Report**

The Town is working with a private pharmacy, PelMed to schedule a vaccine clinic for Concord Middle School (CMS) and Concord Carlisle High School (CCHS). The clinic will be held after

**TOWN OF CONCORD  
SELECT BOARD  
MAY 17 2021  
MINUTES**

school hours at the temporary facility in the CCHS parking lot. The vaccine doses will be provided by the pharmacy. The clinic will be open to families from CMS, CCHS, Carlisle Middle School, and local private schools. Registration will be coordinated by PelMed.

On 5/13/2021, shortly after noon, the Town experienced an outage from one of the three Internet Service Providers that cascaded into a failure of traffic routing on Concord's Broadband and Town network data.

The Town has engaged Concord Resident Ed Hurley-Wales of EHW Consulting to provide Diversity, Equity, and Inclusion services with the expressed goals and aims of increasing inclusion amongst leadership and staff, to better address barriers that limit belonging and full equity, and to create a system and clear roadmap, and increased capabilities.

Seasonal water use restrictions have been imposed for outdoor watering. Whereas, ongoing work associated with the Nagog Pond Intake Replacement project will render this source inoperable into June – compliance with the one-day per week lawn watering restriction is critical. Should customers not abide by these mandatory restriction demand will exceed supply.

The Town has received the attached hearing packet for the Joint Committee on Consumer Protection and Professional Licensure, which will hold a hearing on Thursday, May 20, 2021 on a number of bills including H. 3712. The bill was filed by Rep. Gouveia in accordance with the home rule petition approved at the 2020 Annual Town Meeting (Article 50). The current legislation differs slightly from the Article in that it identifies the four locations that would be eligible for the special licenses; this change was made at the request of legislative counsel.

**Chair's Remarks**

Ms. Escobedo noted the Moody's AAA Bond Rating that was included in the meeting materials, and thanked the Town Manager, Chief Financial Officer and her entire department, the Deputy Town Manager and all the Town's senior management team for providing excellent budgetary guidance to achieve this rating.

**Update on 911 Regional Dispatch Governance Agreement**

The Police Chiefs, Fire Chiefs, and Town Managers of both Concord and Acton attended to present this item. The draft agreement and governance model to establish an independent regional dispatch center for Acton and Concord was included in the [meeting materials](#).

The Select Board questioned the employee composition of the oversight for this agreement, and about outreach to the dispatchers to get their input on the agreement. Mr. Crane stated that this would be sorted out in the next phase, but emphasized a commitment to ensure the same or better working conditions for dispatchers, and that dispatchers from both communities would be represented by the same bargaining unit.

**TOWN OF CONCORD  
SELECT BOARD  
MAY 17 2021  
MINUTES**

The Select Board also questioned the financial impact of adding an Executive Director, Supervisor, and Treasurer. Mr. Crane stated that this would be covered through the state's subsidy for regional centers. The grant application to the state is due on May 31<sup>st</sup>, 2021.

The Police Chiefs and Fire Chiefs of both Acton and Concord responded to community concerns that converting to a regional center would not disrupt any institutional knowledge that existing dispatchers have, emphasizing that modern day dispatchers rely on technology for their roles and are usually not Concord or Acton residents.

The representatives from Concord and Acton both agreed that entering into a regional agreement would result in less cost to both municipalities, and the proposal is supported by the public safety officials of both communities.

The Acton Select Board also will be reviewing this item at their meeting. The Concord Select Board will revisit this item at their May 24<sup>th</sup> meeting.

**Discussion of ATM Warrant Articles Discussed at the May 11 and May 13 Public Hearing**

The Select Board continued their process of taking positions on warrant articles ahead of the 2021 Town Meeting.

#	Article Name	SB Recommendation	Vote
18	Senior Means-Tested Property Tax Exemption	Affirmative Action	Unanimous
19	Appropriation for Senior Means-Tested Tax Exemption	Affirmative Action	Unanimous
20	Light Plant Expenditures & Payment In Lieu of Taxes	Affirmative Action	Unanimous
21	Solid Waste Disposal Fund Expenditures	Affirmative Action	Unanimous
22	Sewer System Expenditures	Affirmative Action	Unanimous
23	Sewer Improvement Fund Expenditures	Affirmative Action	Unanimous
24	Water System Expenditures	Affirmative Action	Unanimous
25	Authorize Expenditure from PEG Access & Cable-Related Fund	Affirmative Action	Unanimous

**TOWN OF CONCORD  
SELECT BOARD  
MAY 17 2021  
MINUTES**

26	Beede Swim & Fitness Center Enterprise Fund Expenditures	Affirmative Action	Unanimous
32	Historic District Map Amendment	Affirmative Action	Unanimous
35	General Bylaw Amendment – Tree Preservation Bylaw	Affirmative Action	Unanimous
36	Zoning Bylaw Amendment – Floodplain Conservancy District	Affirmative Action	Unanimous
37	Zoning Bylaw Amendment – Table IV Minimum Parking	Affirmative Action	Unanimous
38	Zoning Bylaw Amendment – Two-Family or Additional Dwelling Unit	Affirmative Action	Unanimous
39	Zoning Bylaw Amendment – Earth Removal	Affirmative Action	Unanimous

**Review Consent Calendar for 2021 Annual Town Meeting**

Town Moderator Carmin Reiss drafted a consent agenda for the 2021 Annual Town Meeting, which was included in the [meeting materials](#).

The Select Board advised that the Moderator remove Article 38 from the consent calendar, and add Article 32.

There was no vote taken on this matter.

**Article 7 Personnel Bylaw Amendment**

Since the Select Board last discussed Article 7, the Personnel Board met and prepared a proposed amendment to the article. The Town Moderator consulted with Town Counsel and has ruled that the changes proposed were outside the scope of the initial article and were not submitted in time to be included on the warrant.

The Personnel Board will be holding a follow up meeting to consider next steps on Article 7. The Select Board will take a position on Article 7 at a future meeting.

**TOWN OF CONCORD  
SELECT BOARD  
MAY 17 2021  
MINUTES**

**Review 2021 Bond Sale**

Chief Financial Officer Kerry Lafleur reported that the Town received competitive bids from bond underwriters for a \$7,755,000, 10-year new money bond issue and a 5-year, \$1,205,000 General Obligation Refunding issue. The Town received a total of eleven bids on the Bonds. Bids were ranked by lowest True Interest Cost (TIC), with the winning bid received from J. P. Morgan Securities LLC. This original bid provided a True Interest Cost of 0.681177%, including a premium of \$1,672,581.60. The bid from J. P. Morgan Securities LLC was accepted by the Treasurer on behalf of the Town, subject to approval of the Select Board.

Ms. Lafleur is seeking approval from the Select Board to approve the bond award and execute all required documents. The Select Board did not have any objections.

Upon a motion duly made and seconded, it was UNANIMOUSLY

**VOTED:** That in order to reduce interest costs, the Treasurer is authorized to issue refunding bonds, at one time or from time to time, pursuant to Chapter 44, Section 21A of the General Laws, or pursuant to any other enabling authority, to refund the Town's \$8,750,000 General Obligation Municipal Purpose Loan of 2011 Bonds dated May 17, 2011 maturing on May 15 in the years 2022 through 2026, inclusive (the "Refunded Bonds") and that the proceeds of any refunding bonds issued pursuant to this vote shall be used to pay the principal, redemption premium and interest on the Refunded Bonds and costs of issuance of the refunding bonds.

**Roll call vote**

Ms. Escobedo: Aye  
Ms. Bates: Aye  
Ms. Ackerman: Aye  
Ms. Hotchkiss: Aye  
Mr. Johnson: Aye

Upon a motion duly made and seconded, it was UNANIMOUSLY

**VOTED:** that the sale of the \$7,680,000 General Obligation Municipal Purpose Loan of 2021 Bonds of the Town dated May 20, 2021 (the "Bonds") to J.P. Morgan LLC at the price of \$9,146,732.09 and accrued interest is hereby approved and confirmed. The Bonds shall be payable on February 15 of the years and in the principal amounts and bear interest at the respective rates, as follows:

Year	Amount	<u>Interest Rate</u>
2022	\$1,000,000	5.00%
2023	965,000	5.00
2024	975,000	5.00
2025	990,000	5.00

**TOWN OF CONCORD  
SELECT BOARD  
MAY 17 2021  
MINUTES**

2026	1,005,000	5.00
2027	535,000	5.00
2028	545,000	5.00
2029	540,000	5.00
2030	555,000	5.00
2031	570,000	5.00

**Roll call vote**

Ms. Escobedo: Aye  
Ms. Bates: Aye  
Ms. Ackerman: Aye  
Ms. Hotchkiss: Aye  
Mr. Johnson: Aye

Upon a motion duly made and seconded, it was UNANIMOUSLY

**VOTED:** that in connection with the marketing and sale of the Bonds, the preparation and distribution of a Notice of Sale and Preliminary Official Statement dated May 4, 2021 and a final Official Statement dated May 12, 2021, each in such form as may be approved by the Town Treasurer, be and hereby are ratified, confirmed, approved and adopted.

**Roll call vote**

Ms. Escobedo: Aye  
Ms. Bates: Aye  
Ms. Ackerman: Aye  
Ms. Hotchkiss: Aye  
Mr. Johnson: Aye

Upon a motion duly made and seconded, it was UNANIMOUSLY

**VOTED:** to authorize the execution and delivery of a Refunding Escrow Agreement to be dated May 20, 2021, between the Town and U.S. Bank National Association, as Refunding Escrow Agent.

**Roll call vote**

Ms. Escobedo: Aye  
Ms. Bates: Aye  
Ms. Ackerman: Aye  
Ms. Hotchkiss: Aye  
Mr. Johnson: Aye

Upon a motion duly made and seconded, it was UNANIMOUSLY

**VOTED:** that the Town Treasurer and the Select Board be, and hereby are, authorized to execute and deliver a continuing disclosure undertaking in compliance with SEC Rule 15c2-12 in such form as may be approved by bond counsel to the Town, which undertaking shall be incorporated by reference in the Bonds for the benefit of the holders

**Select Board  
Minutes  
May 17, 2021**

of the Bonds from time to time.

**Roll call vote**

Ms. Escobedo: Aye  
Ms. Bates: Aye  
Ms. Ackerman: Aye  
Ms. Hotchkiss: Aye  
Mr. Johnson: Aye

Upon a motion duly made and seconded, it was UNANIMOUSLY

**VOTED:** that we authorize and direct the Town Treasurer to establish post issuance federal tax compliance procedures and continuing disclosure procedures in such forms as the Town Treasurer and bond counsel deem sufficient, or if such procedures are currently in place, to review and update said procedures, in order to monitor and maintain the tax-exempt status of the Bonds and to comply with relevant securities laws.

**Roll call vote**

Ms. Escobedo: Aye  
Ms. Bates: Aye  
Ms. Ackerman: Aye  
Ms. Hotchkiss: Aye  
Mr. Johnson: Aye

Upon a motion duly made and seconded, it was UNANIMOUSLY

**VOTED:** that any certificates or documents relating to the Bonds (collectively, the "Documents"), may be executed in several counterparts, each of which shall be regarded as an original and all of which shall constitute one and the same document; delivery of an executed counterpart of a signature page to a Document by electronic mail in a ".pdf" file or by other electronic transmission shall be as effective as delivery of a manually executed counterpart signature page to such Document; and electronic signatures on any of the Documents shall be deemed original signatures for the purposes of the Documents and all matters relating thereto, having the same legal effect as original signatures.

**Roll call vote**

Ms. Escobedo: Aye  
Ms. Bates: Aye  
Ms. Ackerman: Aye  
Ms. Hotchkiss: Aye  
Mr. Johnson: Aye

Upon a motion duly made and seconded, it was UNANIMOUSLY

**VOTED:** that each member of the Select Board, the Town Clerk and the Town Treasurer be and hereby are, authorized to take any and all such actions, and execute and deliver such certificates, receipts or other documents as may be determined by them, or any of them, to be necessary or convenient to carry into effect the provisions of the foregoing votes.

**Select Board  
Minutes  
May 17, 2021**

**Roll call vote**

Ms. Escobedo: Aye  
Ms. Bates: Aye  
Ms. Ackerman: Aye  
Ms. Hotchkiss: Aye  
Mr. Johnson: Aye

**Committee Nominations**

There were no committee nominations.

**Committee Appointments:**

Upon a motion duly made and seconded, it was UNANIMOUSLY  
**VOTED:** to appoint Chief Financial Officer Kerry Lafleur to the Retirement Board for a term to begin on June 1, 2021, set to expire on April 30, 2024.

**Roll call vote**

Ms. Escobedo: Aye  
Ms. Bates: Aye  
Ms. Ackerman: Aye  
Ms. Hotchkiss: Aye  
Mr. Johnson: Aye

**Committee Liaison Reports**

Ms. Bates attended the Planning Board public hearing, where there was very little public feedback on the proposed articles for the 2021 Town Meeting. The Board of Assessors voted to release the overlay funds related to Article 19. The Board of Assessors is also looking for a new member. The Personnel Board met and developed the proposed amendment to Article 7.

Ms. Ackerman attended the CMLP Board meeting, where they discussed Article 31 and potential amendments. The CMLP Board supported Article 31. The CMLP Board deferred their vote on Article 41. The School Committee introduced the new Director of Diversity, Equity, and Inclusion. The Public Works Commission held a water rates hearing, where they discussed this year's rate increase of 10%.

Mr. Johnson reported that the Public Ceremonies and Celebrations Committee is moving ahead with their Memorial Day commemoration.

**Miscellaneous Correspondence**

Correspondence was included in the [meeting materials](#).

**Select Board  
Minutes  
May 17, 2021  
Public Comments**

There were no public comments.

**Adjourn**

Upon a motion duly made and seconded, it was UNANIMOUSLY  
**VOTED:** to adjourn.

**Roll call vote**

Ms. Escobedo: Aye

Ms. Bates: Aye

Ms. Ackerman: Aye

Ms. Hotchkiss: Aye

Mr. Johnson: Aye

**Meeting Materials:** <https://concordma.gov/DocumentCenter/View/29702/May-17-SB-Packet>

**Minuteman Media Network Coverage:** <https://www.youtube.com/watch?v=vwlzUc4AqA8>

**Select Board  
Minutes  
May 24, 2021**

Pursuant to notice duly filed with the Town Clerk, the Concord Select Board convened in a meeting via video conference on May 24, 2021 at 4:00pm.

Present were Linda Escobedo, Chair; Susan Bates, Clerk; Jane Hotchkiss, Terri Ackerman, and Matthew Johnson. Also present was Stephen Crane, Town Manager.

**Call to Order**

**Roll call vote**

Ms. Escobedo: Present  
Ms. Bates: Present  
Ms. Ackerman: Present  
Ms. Hotchkiss: Present  
Mr. Johnson: Present

**Consent Agenda**

- Minutes to approve: April 26, 2021
- Town Accountant Warrants: May 20, 2021

Upon a motion duly made and seconded, it was UNANIMOUSLY **VOTED:** to approve the consent agenda.

**Roll call vote**

Ms. Escobedo: Aye  
Ms. Bates: Aye  
Ms. Ackerman: Aye  
Ms. Hotchkiss: Aye  
Mr. Johnson: Aye

**Town Manager's Report**

The two-day clinic conducted by the Town at the temporary facility in the CCHS parking lot was highly successful. About 500 doses were administered to students from Concord, Carlisle, and others who had not yet received the vaccine. A second dose clinic will be held in three weeks.

While the Town awaits action by the Legislature and Governor regarding remote participation, plans are being made for boards and committees to resume in-person meetings after June. Given the busy schedules most boards and committees have, it is likely that there will be high demand for meeting spaces. The availability of meeting rooms in Town buildings has been impacted by the space reconfigurations made during the pandemic as well as Town House being offline. For example, some conference rooms were converted to workstations to

**Select Board  
Minutes  
May 24, 2021**

accommodate the social distancing requirements (which remain in effect until 5/29). To ensure that boards and committees have the opportunity to use one of available meeting spaces, room reservations will only be accepted for up to 30 days for non-executive, non-regulatory boards and committees.

Phase 1 construction on Emerson Park will begin on Tuesday May 25 and continue into the summer months with substantial work nearing completion in mid-July.

With continuous pumping helped by a lack of rain in recent days, the upstream flooding at the Sawmil Brook Culvert on Monument Street has been significantly reduced. The plan is to run the pump intermittently depending on rainfall until the permanent repair is done. A contractor has been selected to perform the repairs which include building a coffer dam to isolate the water to allow the removal of the failed portion of the culvert and replacing it with new precast concrete. Work will also include extending the culvert downstream in order to stabilize the embankment on that side.

A mandatory lawn watering restriction, limiting lawn watering to 1 day per week, is in effect. Rising temperatures and a lack of significant rain events predicted in the forecast are already resulting in increased water demands. Until critical infrastructure improvements at the Nagog Pond supply are complete, the water supply and customer demand situation will remain tenuous.

Beginning the week of June 7, Concord COA will begin offering in person programming for fully Covid vaccinated seniors on a limited basis. As expected, there are rules and guidelines that must be followed for any senior to enter the building; COA staff continue to communicate that the policies and rules are fluid, temporary and designed with the goal of mainlining a safe environment for all. The details of these regulations will be published in the COA newsletter which is scheduled to be mailed to all Concord residents aged 60+ during the week of 5/17.

Concord, in partnership with Lexington and Arlington, has been awarded funding to provide technical assistance to study the economic impact of tourism for each of the three towns. MAPC technical assistance is made possible through a range of sources including District Local Technical Assistance, Planning for MetroFuture Technical Assistance, and foundation grants. Awards are also made in alignment with the Baker Administration's Community Compact Cabinet Best Practices Program.

**Chair's Remarks**

Ms. Escobedo's remarks led into the following item regarding the Town's response to the COVID-19 State of Emergency Order expiring on June 15 and associated follow-up actions.

**Select Board  
Minutes  
May 24, 2021**

**Town of Concord Response to the Governor Rescinding the Declaration of Emergency Order**

The COVID-19 State of Emergency is scheduled to expire on June 15, 2021. With no further legislative action, Open Meeting Law changes that allowed for virtual meetings would revert back to pre-pandemic requirements. The result is that boards and committees would have to meet with a quorum in person beginning on June 15. Public participation via Zoom would still be allowed.

Additionally, the ability for restaurants to continue outdoor dining as approved under the COVID-19 Emergency Order is set to expire 60 days after the end of the State of Emergency (August 15, 2021). Once this expires, restaurants would need to apply to amend their liquor license to be able to serve alcohol outdoors and would need to meet the Zoning Bylaw's parking requirements for additional outdoor seating, which was waved under the emergency order.

In order to codify the ability for virtual participation in Open Meeting Law, the Select Board proposed submitting a letter to the legislature to support H.3213 and S.2104: An Act updating the Open Meeting Law to support remote participation.

Upon a motion duly made and seconded, it was UNANIMOUSLY

**VOTED:** to authorize the chair to send a letter of support to Concord's legislative representatives for H.3213 and S.2104: An Act updating the Open Meeting Law to support remote participation and incorporating comments as noted in this meeting.

**Roll call vote**

Ms. Escobedo: Aye

Ms. Bates: Aye

Ms. Ackerman: Aye

Ms. Hotchkiss: Aye

Mr. Johnson: Aye

**Update on Assistive Technology Plans for Town Buildings**

Deputy Town Manager Kate Hodges attended the meeting to present on assistive listening devices at Town facilities. The Council on Aging hosts a hearing support subcommittee to understand the assistive listening capability of Town buildings. The subcommittee is developing a report for the Deputy Town Manager and the Commission on Disabilities.

**911 Regional Dispatch Governance Agreement**

The Select Board revisited the application for the 911 Regional Dispatch Governance Agreement between the Town of Concord and the Town of Acton. The deadline for the

**Select Board  
Minutes  
May 24, 2021**

application is May 31, 2021. The Select Board heard presentations and citizen feedback at multiple meetings leading up to this meeting. Thomas Kennedy of the Edward Collins Center attended the meeting to reiterate the cost saving and operational benefits of Acton and Concord developing a regional center. Select Board members had questions regarding the terms and conditions for potential withdrawal from the agreement should that be necessary, as well as the financial impact of adding additional communities to a regional operation. Mr. Crane reiterated that if the funding application was not accepted by the state, Concord could back out of the proposal at no cost. If desired, the Town would be able to back out of the agreement and revert back to the current dispatch model at any time with notice. The public safety officials and town managers from Acton and Concord have both advised that the Town's enter into this agreement.

The Select Board initially voted on a motion to support the Town of Concord and Town of Acton Regional Dispatch Governance Agreement as presented at the meeting. This motion was rescinded later on in the meeting as it did not comply with the language required by the statute, at which time the Chair made the following motion quoting the required statutory language.

Upon a motion duly made and seconded, it was

**VOTED:** shall the municipality accept the provisions of sections of 18.0-18b inclusive of chapter 6a of the general laws providing for the establishment of a regional 911 emergency communication district together with the Town of Acton and the construction, siting, administration, operation, and maintenance of a regional 911 emergency communication center by the district under the provisions of the proposed district agreement filed with the Select Board in Concord and Acton.

**Roll call vote**

Ms. Escobedo: Aye

Ms. Bates: Aye

Ms. Ackerman: Aye

Ms. Hotchkiss: Nay

Mr. Johnson: Nay

**Applications for New Tour Guide Licenses**

Victor Curran, the teacher of the Concord History course that new tour guides are required to complete, attended to present the list of tour guides applying for a license. Mr. Curran congratulated the guides on the completion of the course.

Upon a motion duly made and seconded, it was UNANIMOUSLY

**VOTED:** to approve the applications for new tour guide licenses valid through December 31, 2021 as included in the meeting materials dated May 24, 2021.

**Roll call vote**

**Select Board  
Minutes  
May 24, 2021**

Ms. Escobedo: Aye  
Ms. Bates: Aye  
Ms. Ackerman: Aye  
Ms. Hotchkiss: Aye  
Mr. Johnson: Aye

**Committee Nominations:**

Thomas Swaim of 28 Central Street to the Zoning Board of Appeals for a term to expire on April 30, 2024. Elizabeth Akehurst-Moore of 86 Holden Wood Road to a second term on the Zoning Board of Appeals to expire on April 30, 2024. Andrew Boardman of 110 Hillcrest Road to the Planning Board for a term to expire April 30, 2026. Josh Galper of 65 Stone Root Lane to the White Pond Advisory Committee for a term to expire on April 30, 2024.

**Town Manager Appointment with Select Board Approval:**

Upon a motion duly made and seconded, it was UNANIMOUSLY

**VOTED:** to approve the Town Manager Appointment of Gary Kleiman of 57 Central Street to the Natural Resources Commission for a term to expire on April 30, 2024.

**Roll call vote**

Ms. Escobedo: Aye  
Ms. Bates: Aye  
Ms. Ackerman: Aye  
Ms. Hotchkiss: Aye  
Mr. Johnson: Aye

**Committee Liaison Reports**

Committee liaison reports were deferred to the next meeting. Mr. Johnson reported that the Middle School Building Committee will be holding an additional meeting next week to describe the final space summary and the projected budget.

**Miscellaneous Correspondence**

Correspondence was included in the [meeting materials](#).

**Public Comments**

**Select Board  
Minutes  
May 24, 2021**

Lois Suarez of 34 Everett Street asked why the tour guide licenses approved earlier in the meeting only run through December 31, 2021, rather than a full year. Senior Administrative Assistant Jeremy Romanul noted that this term corresponds with the term adjustments approved by the Select Board earlier in the year. Tour guide license will be renewed on a calendar year basis moving forward, with terms beginning on January 1.

**Adjourn**

Upon a motion duly made and seconded, it was UNANIMOUSLY  
**VOTED:** to adjourn.

**Roll call vote**

Ms. Escobedo: Aye  
Ms. Bates: Aye  
Ms. Ackerman: Aye  
Ms. Hotchkiss: Aye  
Mr. Johnson: Aye

**Meeting Materials:** <https://concordma.gov/DocumentCenter/View/29772/May-24-SB-Packet>

**Minuteman Media Network Coverage:** <https://www.youtube.com/watch?v=nwevBiN5leE>



**TOWN OF CONCORD**  
**Office of the Town Manager**  
Town House  
P.O. Box 535  
Concord, Massachusetts 01742

TEL: 978-318-3000  
FAX: 978-318-3002

Stephen Crane, Town Manager

## MEMORANDUM

To: Chair Escobedo and Members of the Board

From: Stephen Crane, Town Manager

Date: June 21, 2021

Re: Town Manager Report

---

### **Statement about Juneteenth**

Attached is a statement that was posted about the Juneteenth holiday. The Town's DEI advisors assisted in the drafting of the statement.

### **Extension of Open Meeting Law Provisions and Outdoor Dining**

Earlier this week, the Legislature approved, and the Governor signed, extensions to certain provisions from the pandemic emergency orders including the extension of outdoor dining and the Open Meeting Law (OML) modifications that allow for virtual meetings. Regarding outdoor dining, the bylaw change approved on the consent calendar at Town Meeting cleared the path for outdoor dining to continue under local rules. Regarding the OML extension, the Town has made provisions to accommodate in person, hybrid, and continued virtual meetings. However, the methods being employed for hybrid meetings have some limitations that need further work and the Select Board meeting spaces in the Town House remain unavailable. The extension will provide an opportunity for additional improvements and bring the Town House rooms online once the renovations are complete.

### **CFPL**

Staff and volunteers warmly welcomed patrons back to the Library on May 19. Patrons and visitors were so happy when they entered the Main and Fowler. Some of them checked out loads of books and audio-visual materials. There was a record-breaking 1,499 checkouts within eight hours on the re-opening day! As a result of the reopening, there have been several changes to services including limited curbside service. Public meeting rooms are now available and public computers will be available on June 21. Also, the "Tails and Tales" Summer Reading Program Officially Started on June 14<sup>t</sup> with over 230 children and 25 adults registered for the Summer Reading Program.

### **CPW**

MCI Daily Work Release Program: As Concord Public Works enters into one of the busiest seasons of the year for the department, the Highway & Grounds Division continues to provide a high level of service to the residents and businesses in the Town of Concord. Spring and Sumer

seasonal maintenance includes a wide variety of activities that require daily deployment of all crew members. While the Division is operating with a temporary absence of three full time equipment operators (in-hiring process), we have just learned that MCI Concord is prepared to re-initiate their daily work release program. This program has historically been utilized by CPW to support seasonal Town maintenance needs.

Activation of Public Water Fountains. In keeping with the relaxation of COVID protocols and just in time for increased outdoor seasonal activities, the Water/Sewer Division has been re-activating public water fountains (hydration stations) throughout the community.

### **DPLM**

Economic Vitality Committee: Director Rasmussen met with EVC Co-Chair John Boynton to review a draft scope of work to discuss with the consultant previously funded by a DHCD Downtown Initiative program to assist the EVC with outreach efforts to identify what has been learned over the past 15 months that can be used to support economic recovery and growth. Additionally, the Summer Solstice local business program is back for a second year. The program flyer is attached.

Ranger Program: This week two seasonal, full time rangers began working to monitor activity and remind residents/visitors of the rules regarding use of Town open spaces. After receiving reports of people using the future BFRT south of Powder Mill Road as a point of access to White Pond, they will be monitoring the trails and posting signs stating “No Bikes and No Swimming” along the trail.

Natural Resources Commission: A permit was issued for the Amended NOI and the hearing closed for the White Pond project. The NRC also issued three additional rules for Sachem’s Cove, to assist the Rangers in preserving and protecting White Pond and its watershed: No beach floats, no loud music, and no flyfishing.

White Pond Blue-Green Algae: Health Division staff received a number of calls asking about the algae bloom at White Pond. Water use advisory signage has been posted at all public access points to the pond and a public advisory notice about the pond was prepared for distribution via News and Notices and social media. This year, as in previous years, the Health Division will provide these updates as needed when conditions at the pond change.

### **Fire Department Activity**

Ninety calls for service. Including a vehicle fire on Monday 6/14. The fire occurred on Rte. 2 in front of the State Police Barracks during the evening rush hour. The fire was stubborn because part of the engine was made with magnesium that typically does not respond to conventional firefighting technique. There were no injuries.



Posted on: June 18, 2021

## **Statement of Town Manager Stephen Crane on Juneteenth**

### **Statement of Town Manager Stephen Crane on Juneteenth**

Yesterday, President Biden signed a new law making Juneteenth a federal holiday after Congress overwhelmingly approved it. Juneteenth, celebrated on the 19<sup>th</sup> of June, celebrates the ending of slavery in the United States. While the Emancipation Proclamation had been signed on January 1<sup>st</sup>, 1863, it wasn't until June 19<sup>th</sup>, 1865, two and a half years later, that Union soldiers brought the news to Galveston Texas that Civil War had ended and that enslaved people were now free.

The effort to have Juneteenth recognized as a holiday stretches back many years; the alacrity Congress showed in passing the legislation is a clear sign of the social and political change we are experiencing.

While this important holiday being recognized as an official federal holiday is a significant milestone in our journey toward greater diversity, equity, and inclusion, maintaining forward progress requires constant effort and attention. We must continue to address the social, economic, and political factors that impede progress. We must continue to look ahead for the next important milestone and strive to reach it.

As a freshman in college 30 years ago, I reached my first important milestone on my journey when I was a founding member of a student group focused on what was then known as multi-culturalism. The experience was both formative, in that I was painfully unaware of the widespread struggle for equity and inclusion, and transformative, in that I learned to embrace diversity and that the idea of "we are all the same" is about our humanity, not our cultures and values. I have carried these lessons with me since then and am fortunate to play a small role in promoting diversity, equity, and inclusion in Concord.

Our community has a rich African American history that perhaps isn't as well-known as our literary or Revolutionary history, but its contributions are seen and felt by Concordians on a daily basis. The families who have made significant contributions include names like Thomas and Jennie Dugan, Caesar Robbins, a Revolutionary War Patriot and namesake of the Robbins House in Concord, and Brister Freeman, namesake of Brister's Hill, to name a few. Concord is continuing on its journey, as is much of the United States, to better recognizing its African American history and honoring Juneteenth in Concord is an important milestone in that journey.

The Town is celebrating Juneteenth through a series of social media posts, special walking tours at the Concord Visitor Center, and by supporting Concord's African American History resource and museum, the Robbins House. Due to both the Town bylaws and collective bargaining agreements, municipal operations will continue as usual on Friday, June 18 and, although Saturday, June 19 now is a legal holiday, certain operations will continue that day (e.g., public safety, Beede Center/White Pond/Emerson Pool, Visitor's Center) as is customary on many other holidays.

In addition to observing Juneteenth, we are engaged in an effort to promote diversity, equity, and inclusion with the expressed goals and aims of increasing inclusion amongst leadership and staff, to better address barriers that limit belonging and full equity, and to create a system and clear roadmap, and increased capabilities. The initial phase of what is expected to be an ongoing effort are as follows:

- A Leadership Assessment consisting of individual interviews with each Senior Management Team member and other designated individuals will help us determine our readiness, strength, gaps, and recommendations for next steps and considerations towards full equity and inclusion.

- An Education & Learning component for the Senior Management Team and other designated individuals to bolster diversity, equity, and inclusion knowledge base and enhance Inclusive Leadership capabilities.
- The Development of a Strategic Road Map to meet and maximize Diversity, Equity, and Inclusion goals.
- Recommendation and consultation on key policies, procedures, and practices to mitigate or eliminate bias in key areas: improve talent recruitment, development, and retention and bolster communication around DEI.

Finally, as part of both the work above and the future observances of Juneteenth, the Town will work to revise its holiday policies so they provide a more inclusive workplace that gives employees the opportunity to celebrate holidays that are important to them.

# CONCORD

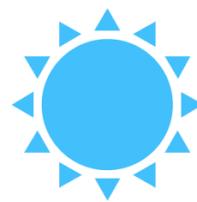

# SOLSTICE

*Sponsored by Concord Chamber of Commerce, Concord Together, and the Town of Concord*

**Shop at least 10 Concord  
businesses either in person  
or on-line between  
JUNE 21<sup>ST</sup> TO AUGUST 20<sup>TH</sup>  
and you could win a  
WEEKLY PRIZE  
or the  
GRAND PRIZE!**

*TRY 2 NEW STORES YOU'VE NEVER BEEN TO BEFORE.*

**TO ENTER:** Let the retailer know at check out that you would like to enter the Concord Solstice. Passports to be stamped in stores you visit (boards available in each store). Keep your online receipts.

**PETITION FOR UNDERGROUND INSTALLATION OF COAXIAL CABLE**

Concord, Massachusetts

**05/27/2021**

To the Selectboard of Concord, Massachusetts:

**Comcast of Massachusetts III, Inc.** requests permission to install coaxial cable to be owned and used by the petitioner, along and across the following public way or ways:

- *Hubbard Street*

Wherefore they pray that after due notice and hearing as provided by law, they be granted permission to install underground coaxial cable as they may find necessary and in accordance with the plan filed herewith.

**Comcast of Massachusetts III, Inc.**

By: *Gregory Franks*

Print name: Gregory Franks

Title: Sr. Manager of Government and Regulatory Affairs

Telephone or e-mail contact info: (617) 862-8437 cell phone

Gregory\_Franks@comcast.com

## ORDER FOR INSTALLATION OF UNDERGROUND COAXIAL CABLE

In Selectboard of the Town of Concord, Massachusetts

Notice having been given and a public hearing held, as provided by law,

IT IS HEREBY ORDERED: that **Comcast of Massachusetts III, Inc.** be and is hereby granted permission to install coaxial cable as it deems necessary, in the public way or ways hereinafter referred to, as requested in the said petition and accompanying plan.

All construction under this order shall be in accordance with the following conditions:

The new coaxial cable will be installed, starting at the existing Comcast vault located in front of 35 Hubbard Street, excavating to install PVC conduit 164'+/- to a proposed vault that will be installed in the sidewalk over the existing conduit that services the church. Then, from the newly installed vault, excavating across the street 94'+/- to a proposed vault to be installed in the sidewalk, installing PVC conduit 4'+/- to the property line for future service to the post office. There may be installed by said Comcast of Massachusetts III, Inc. such coaxial cables as are necessary in its business and all said coaxial cables shall be placed in a manner that complies with the National Electrical Safety Code.

The following are the public ways or parts of ways along which the above referred to may be installed thereon under this order:

- *Hubbard Street*

I hereby certify that the foregoing order was adopted at a meeting of the Selectboard of the Town of Concord, Massachusetts held the \_\_\_\_\_ day of \_\_\_\_\_, 2021.

---

Clerk of Board of Selectmen

We hereby certify that on \_\_\_\_\_, at \_\_\_\_\_ O'clock \_\_\_\_\_, at Concord, Massachusetts, a public hearing was held on the petition of **Comcast of Massachusetts III, Inc.** permission to install coaxial cables, fixtures and connections described in the order herewith recorded, and that we mailed at least seven days before said hearing a written notice of the time and place of said hearing to each of the owners of real estate (as determined by the last preceding assessment for taxation) along the ways or parts of ways upon which the Company is permitted to install coaxial cables, fixtures and connections under said order. And that thereupon said order was duly adopted.

\_\_\_\_\_  
\_\_\_\_\_  
\_\_\_\_\_  
\_\_\_\_\_  
\_\_\_\_\_

Selectboard of the Town of Concord, Massachusetts

**CERTIFICATE**

I hereby certify that the foregoing is a true copy of a location order and certificate of Hearing with notice adopted by the Selectboard of the Town of Concord, Massachusetts, on the \_\_\_\_\_ day of \_\_\_\_\_, 2021. This certified copy is made under the provisions of Chapter 166 of General Laws and additions thereto or amendments thereof.

Attest: \_\_\_\_\_  
Town Clerk

PROPOSED COMCAST UNDERGROUND CONDUIT, 1-3" PVC, SCH. 40, L=164'± (EXISTING VAULT TO NEW. VAULT#1)

NEW COMCAST VAULT#2 (24"X36") IN CONC. SIDEWALK

NEW COMCAST SERVICE CONDUIT 1-3" PVC, SCH. 40, L=4'± (NEW VAULT#2 TO ROW LINE)

EXIST. COMCAST VAULT W/COVER LABELED ELECTRIC REPLACE WITH NEW COMCAST (17" X 30") VAULT IN GRASS STRIP

EXIST. ELECTRIC LINE IN STREET BETWEEN CURB AND GAS LINE (FROM UP TO WALDEN STREET)

NEW COMCAST VAULT #1 (24"X36") IN BIT. CONC. SIDEWALK

CONC. WALK TO CHURCH

PROPOSED COMCAST UNDERGROUND CONDUIT, 1-3" PVC, SCH. 40, L=94'± (NEW VAULT#1 TO NEW. VAULT#2)

HUBBARD STREET (PUBLIC - 50 FT. WIDE)

HUBBARD STREET (PUBLIC - 50 FT. WIDE)

**LEGEND**

- CB CATCH BASIN
- ⊙ LP LIGHT POLE
- ⊗ WG WATER GATE
- ⊙ MH MANHOLE
- ⊙ TM TELEPHONE MANHOLE
- ⊙ EM ELECTRIC MANHOLE
- ⊙ L/PB LIGHT POLE BASE (NO LIGHT)
- E/HH ELECTRIC HAND HOLE
- ⊙ SM SEWER MANHOLE
- ⊙ DM DRAIN MANHOLE
- VGC VERTICAL GRANITE CURB
- ⊙ UTILITY POLE
- ⊙ SIGN
- 15"DT DECIDUOUS TREE
- SB STEEL BOLLARD

- G — GAS LINE
- W — WATER LINE
- T — TELEPHONE LINE
- E — ELECTRIC CONDUIT
- S — SEWER LINE
- D — DRAIN LINE
- C — CATV LINE
- — — APPROX. P.L.
- — — PROPOSED COMCAST UNDERGROUND CONDUIT
- — — DBL YELLOW CENTER LINE
- — — SINGLE YELLOW EDGE LINE
- — — SINGLE WHITE EDGE LINE
- — — SINGLE WHITE LANE LINE
- — — SINGLE WHITE LINE

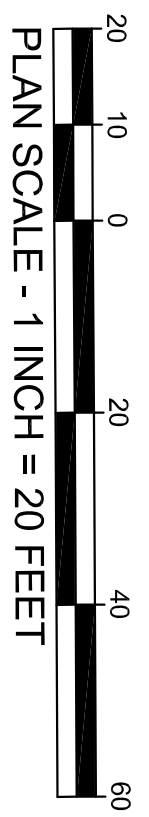

**PRECINCT 1**

PROPOSED COMCAST UNDERGROUND  
MIDDLESEX COUNTY

PLAN OF LAND  
IN  
**CONCORD, MA**

Prepared for:  
**COMCAST**  
9 FORBES ROAD, SUITE 9B  
WOBURN, MA 01801

Prepared By:  
**DEWSNAP ENGINEERING ASSOC. LLP**  
178 Lincoln Avenue - Saugus, MA 01906  
Tel.#:(781) 233-0595

Date: May 19, 2021  
Scale: As Shown

Checked By: F.D.D. & P.A.D.  
PROJECT LOCATION:  
**35 HUBBARD STREET  
CONCORD, MA**

Drawn By: W.A.J.  
Field By: N/A  
Sheet No. 1 of 4



THIS PLAN IS DRAWN ON 11" X 17" PAPER.

**NOTES:**

1. These plans were prepared from record data on file at the Town of Concord Engineering Department and various utility companies.
2. The locations of underground utilities shown are based on the above referenced data. Locations of underground utilities/structures may vary from location hereon and are not warranted to be accurate and/or correct. Additional buried utilities/ structures may be encountered. No excavations were performed during the progress of this survey to locate buried utilities/structures.
3. Prior to any construction the Contractor shall notify DIG-SAFE at least 72 hours in advance at 811 (National Call Number) for verification of utilities and for field locations.
4. It is the responsibility of the utility contractor installing the Comcast underground conduit, manholes and vaults to notify those utility companies not associated with the DIG-SAFE system to verify the locations of their respective utilities. Also, the installing contractor shall be responsible for repairing or replacing any traffic signal loops damaged during the installation of the new Comcast underground conduits and vaults.
5. Prior to the start of construction, the Utility Contractor shall confirm the number of conduits and size of the conduits for this project with the Comcast Project Coordinator.
6. These plans were prepared for permitting purposes with the Town of Concord, MA. After all utility lines have been marked out in the field the locations of the Proposed Comcast Underground Conduit and Vaults may be adjusted to fit with the existing utilities in the field.
7. All work to be performed is for the installation of the New Comcast underground conduit and vaults.
8. All work shall conform to the approving authorities Engineering and DPW Standards.
9. Upon completion of the trench work for the day, the contractor shall backfill, compact and pave the trench in all roadway and sidewalk areas and the work area shall be broom swept clean. In grassed areas the trench shall be loamed, seeded and hay mulch spread to keep the area stabilized until the grass has taken hold.
10. All concrete sidewalks disturbed or damaged by the placement of the Comcast Underground Conduit shall be repaired/replaced in kind in accordance with the Town of Concord Standards and requirements. All Curbing, Signage, Road and Parking stripping and traffic signal conduits, wiring or detection loops disturbed during the placement of the Comcast Underground Conduit shall be restored/replaced to their original condition by the Utility Contractor. All property and street line bounds and markers expected to be damaged or disturbed by the placement of the Comcast Underground Conduit shall be located and tied in by a Massachusetts Registered Professional Land Surveyor prior to the work and shall be replaced by the Land Surveyor as part of the project.
11. Street/Property lines are not the result of a boundary survey and are considered to be approximate.

**CONSTRUCTION NOTES:**

1. Following the Dig-Safe "mark out" and field verification of the existing underground utilities, the Proposed 3" PVC, Schedule 40 Comcast Conduit shall be adjusted in the field by the utility contractor to avoid being located over any existing utilities.

**DETAIL NOTES:**

1. The details depicted are for general reference only. The final product used shall be the responsibility of the general contractor and shall be of equal or greater material than that depicted and shall conform to the Engineering/DPW Standards for the City/Town and/or State where the project is located.

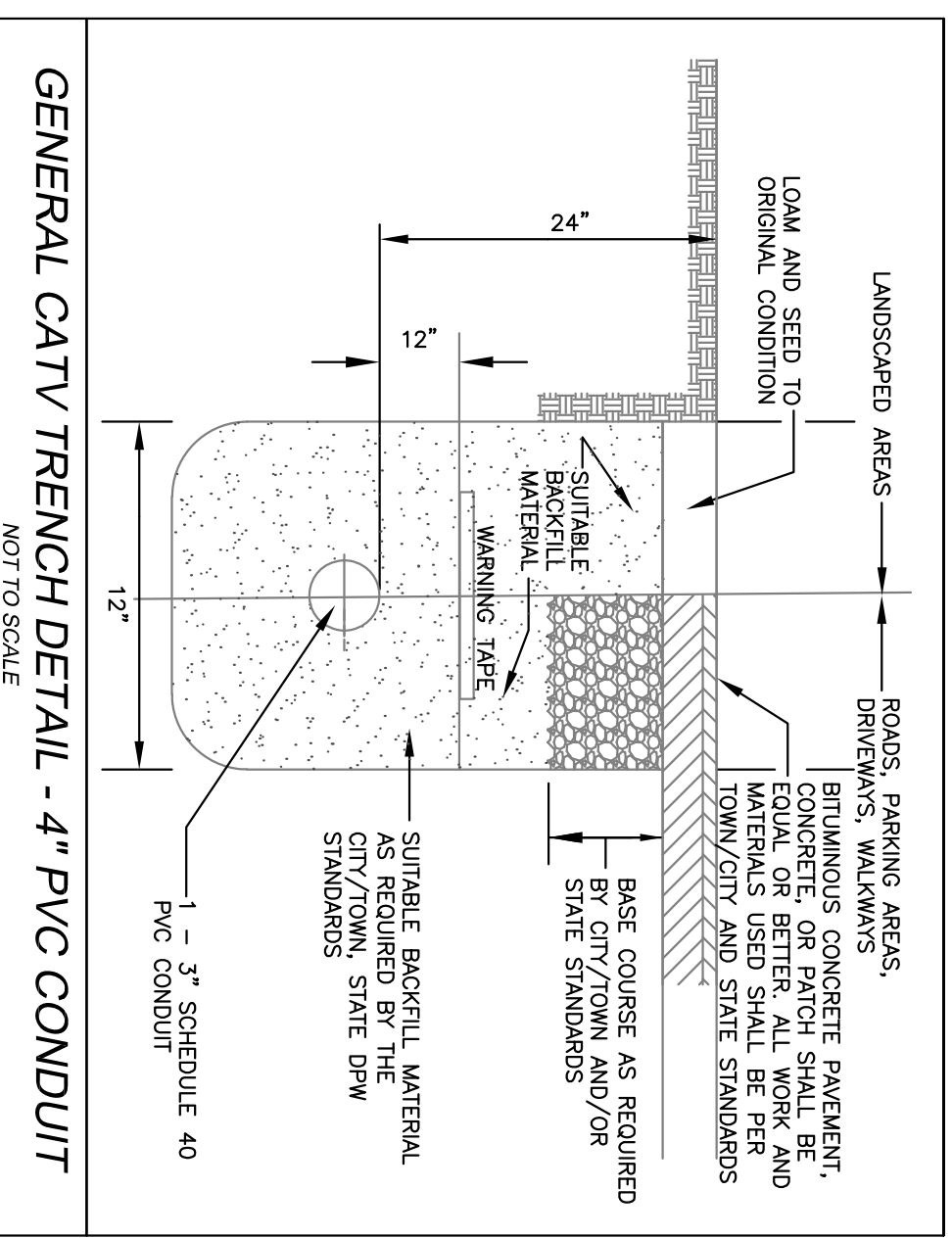

THIS PLAN IS DRAWN ON 11" X 17" PAPER.

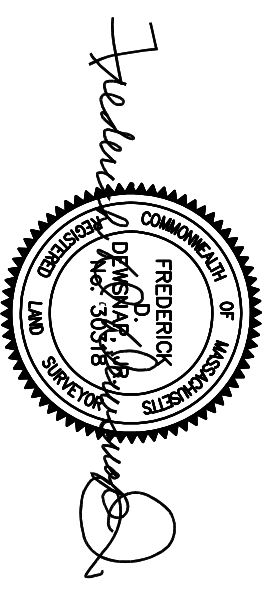

<b>PROPOSED COMCAST UNDERGROUND MIDDLESEX COUNTY</b>	
<b>PLAN OF LAND IN CONCORD, MA</b>	
<b>PRECINCT 1</b>	
<b>PROPOSED COMCAST UNDERGROUND</b>	
<b>MIDDLESEX COUNTY</b>	
<b>PLAN OF LAND IN CONCORD, MA</b>	
Prepared for:	Prepared By:
COMCAST 9 FORBES ROAD, SUITE 9B WOBURN, MA 01801	DEWSNAP ENGINEERING ASSOC. LLP 178 Lincoln Avenue - Saugus, MA 01906 Tel#:(781) 233-0595
Date: May 19, 2021	Scale: As Shown
Checked By: F.D.D. & P.A.D.	PROJECT LOCATION:
Drawn By: W.A.J.	35 HUBBARD STREET CONCORD, MA
Field By: N/A	
Sheet No. 2 of 4	

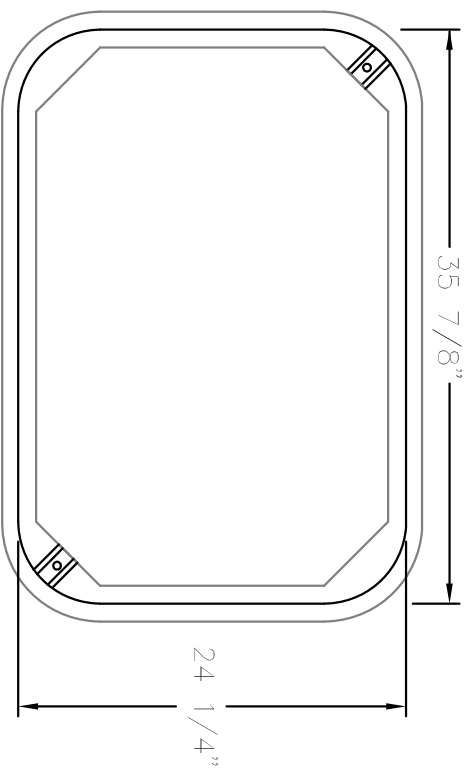

PLAN VIEW

APPROX. WT. = 304 LBS.

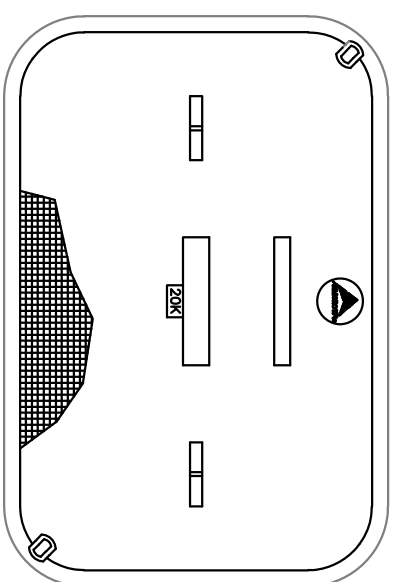

POLYMER CONCRETE COVER

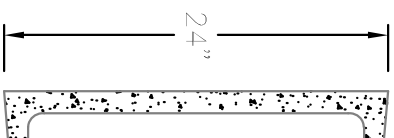
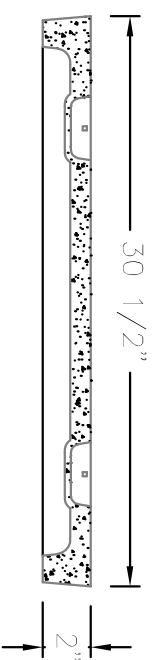

LIFT PIN (2X)

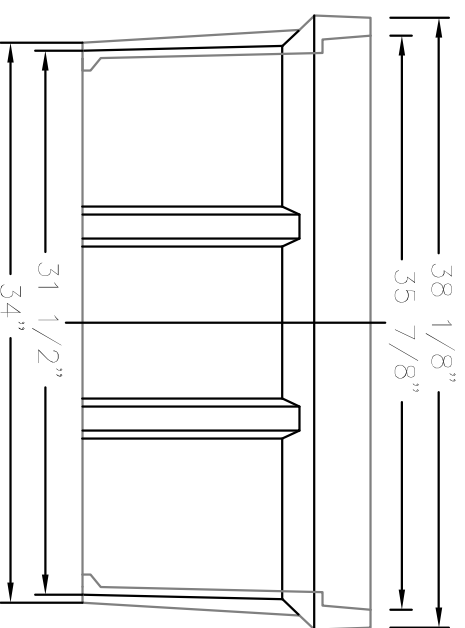
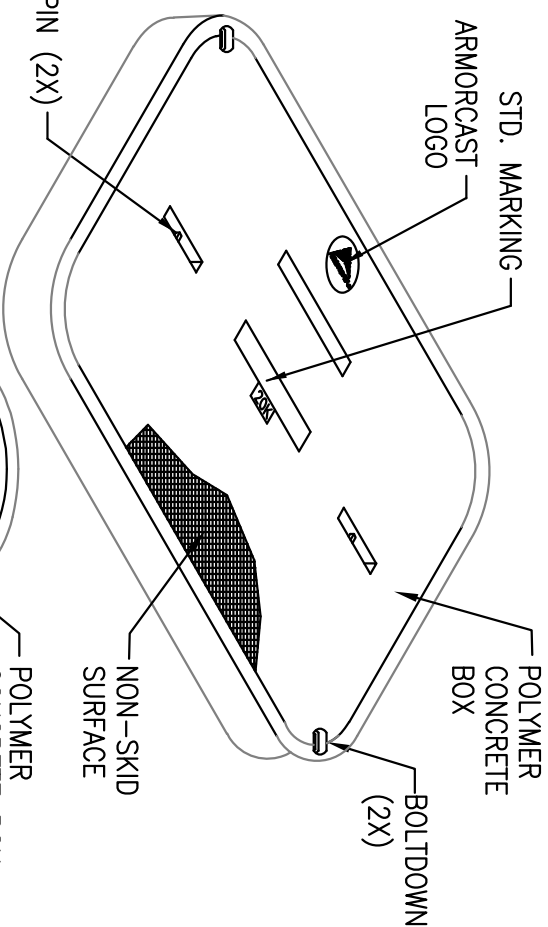

SIDE VIEW

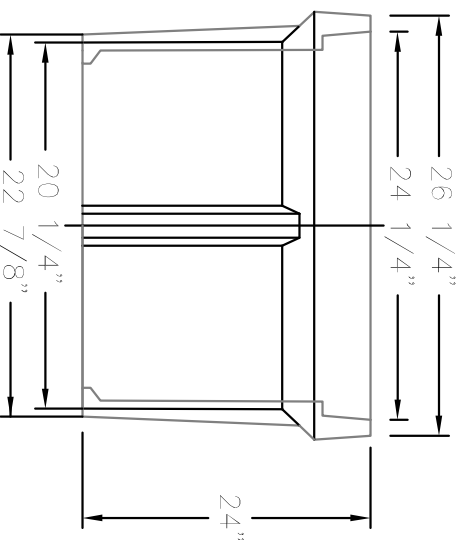

END VIEW

**ARMORCAST 24" X 36" VAULT DETAIL**

NOT TO SCALE

**VAULT NOTES:**

VAULTS SHALL BE AS MANUFACTURED BY ARMORCAST PRODUCTS COMPANY, CHASTWORTH, CA, 24" X 36" X 24" DEEP, TIER 22, 20K LOAD RATED, MODEL #A6001974HDAPCX24.

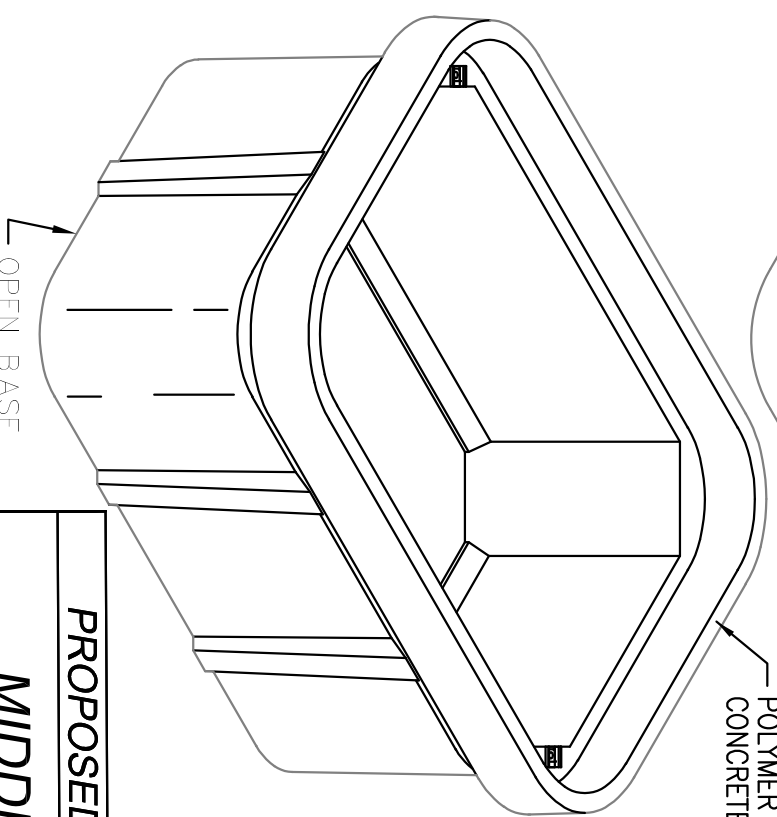

**PRECINCT 1**

**PROPOSED COMCAST UNDERGROUND**

**MIDDLESEX COUNTY**

**PLAN OF LAND  
IN  
CONCORD, MA**

Prepared for:	COMCAST 9 FORBES ROAD, SUITE 9B WOBBURN, MA 01801	Prepared By:	DEWSNAP ENGINEERING ASSOC. LLP 178 Lincoln Avenue - Saugus, MA 01906 Tel.#:(781) 233-0595
Date:	May 19, 2021	Scale:	As Shown
Checked By:	F.D.D. & P.A.D.	PROJECT LOCATION:	35 HUBBARD STREET CONCORD, MA
Drawn By:	W.A.J.		
Field By:	N/A		
	Sheet No. 3 of 4		



THIS PLAN IS DRAWN ON 11" X 17" PAPER.

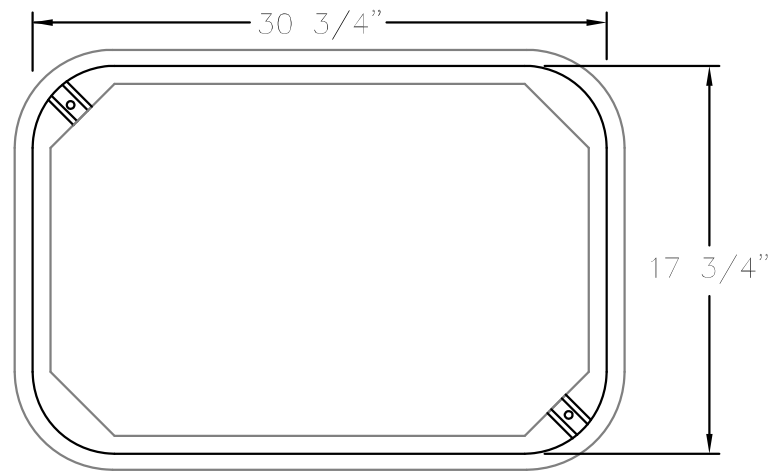

PLAN VIEW

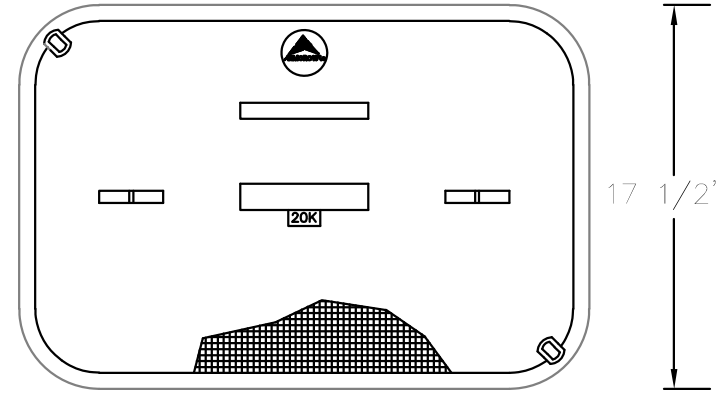

POLYMER CONCRETE COVER

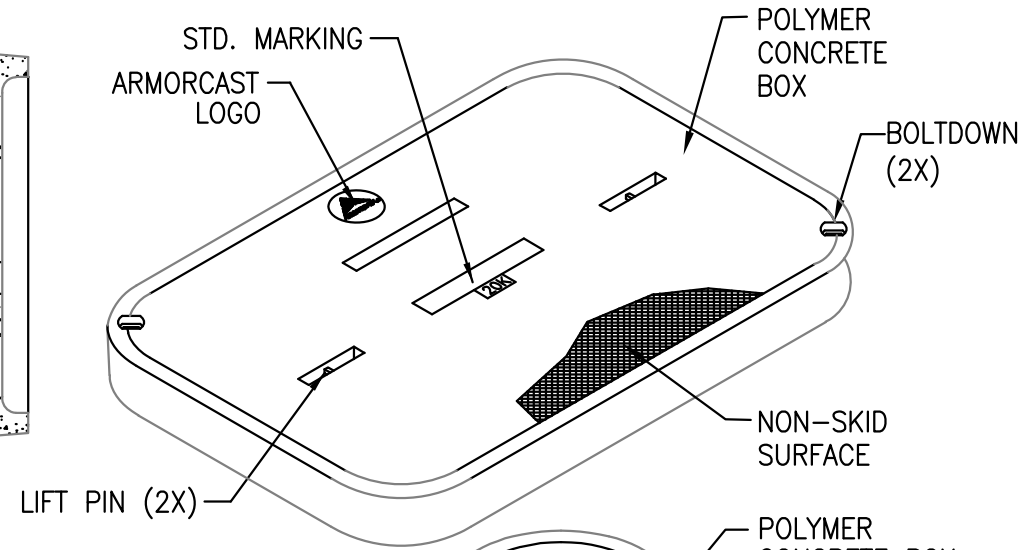

APPROX. WT. = 190 LBS.

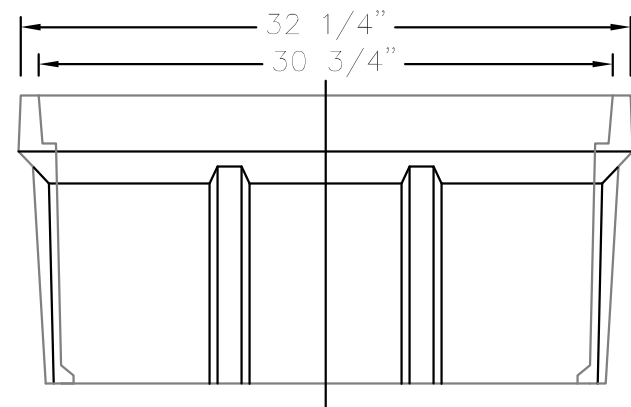
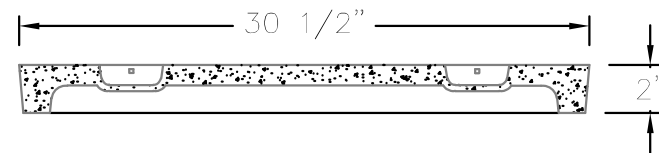

SIDE VIEW

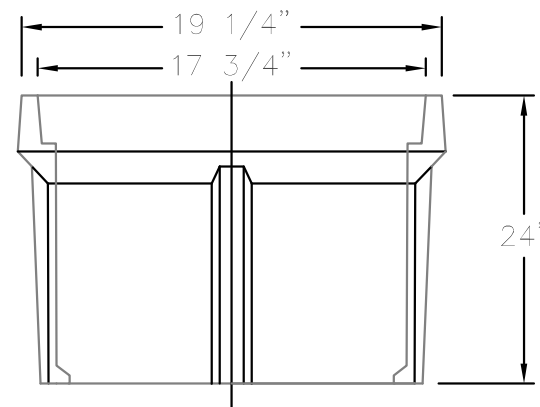

END VIEW

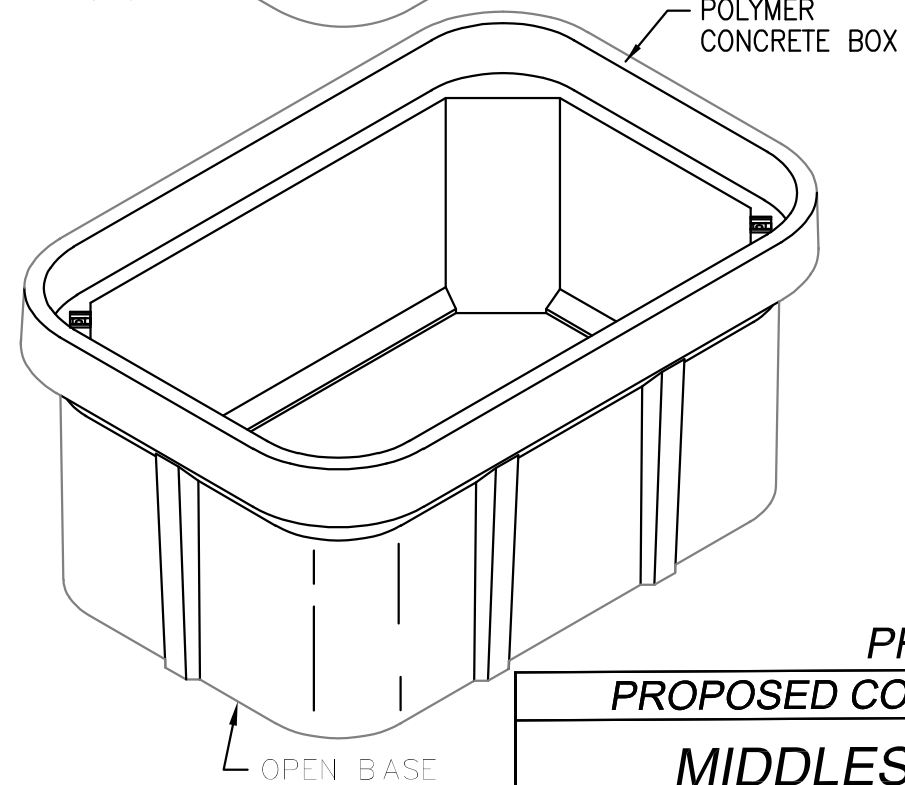

**ARMORCAST 17" X 30" VAULT DETAIL**  
NOT TO SCALE

**VAULT NOTES:**

1. VAULTS SHALL BE AS MANUFACTURED BY ARMORCAST PRODUCTS COMPANY, CHASTWORTH, CA, 17" X 30" X 24" DEEP, TIER 22, 20K LOAD RATED, MODEL #A6001640HDAPCX24



THIS PLAN IS DRAWN ON 11" X 17" PAPER.

<b>PRECINCT 1</b>	
<b>PROPOSED COMCAST UNDERGROUND</b>	
<b>MIDDLESEX COUNTY</b>	
<b>PLAN OF LAND</b>	
<b>IN</b>	
<b>CONCORD, MA</b>	
Prepared for: <b>COMCAST</b> 9 FORBES ROAD, SUITE 9B WOBURN, MA 01801	Prepared BY: <b>DEWSNAP ENGINEERING ASSOC. LLP</b> 178 Lincoln Avenue - Saugus, MA 01906 Tel.#:(781) 233-0595
Date: May 19, 2021	Scale: As Shown
Checked By: F.D.D. & P.A.D.	PROJECT LOCATION: <b>35 HUBBARD STREET</b> <b>CONCORD, MA</b>
Drawn By: W.A.J.	
Field By: N/A	
Sheet No. 4 of 4	

**133 Keyes Road  
Concord, MA 01742**



**DATE: 06/01/2021**

**MEMORANDUM**

**TO: Jeremy Romanul, Senior Administrative Assistant**  
**CC: Stephen Crane, Town Manager**  
**VIA: Alan Cathcart, Director of Public Works**  
**FROM: Stephen Dookran PE, Town Engineer**  
**PREPARED BY: Patrick Wood, PE, Public Works Engineer**  
**SUBJECT: Petition from Comcast to install approximately 262 feet of Coaxial Cable in 3" PVC conduit in Hubbard Street and two new vaults within the sidewalks, in front of #54 and #34 Walden St.**

This memorandum is to provide comments to the Select Board on the petition for a Grant of Location filed by Comcast to install 262 feet of schedule 40 polyvinyl chloride (PVC) conduit on Hubbard Street for the purpose of running coaxial cable underground. Hubbard Street reconstruction is part of Concord Public Work's (CPW's) FY2021 Roads Program and is scheduled for full depth reconstruction with funding allotted through municipal funds and a Complete Streets grant. The Town is contractually obligated with the Complete Streets grant to complete the Hubbard Street reconstruction project by September 30, 2022.

Comcast is proposing this petition in order to move the remaining overhead cables underground from #35 Hubbard St. to Walden St. and to add service to the Post Office at the Corner of Hubbard St. and Walden St. Following the completion of the underground installation of cables and vaults, Comcast will remove the overhead cables.

As explained in a memo regarding the Grant of Location Petition from National Grid, dated May 27, 2021, the Town will begin undertaking stormwater improvements within the area of Comcast's proposed work. The drainage system cannot be completed without Comcast coordinating their work with the Town's selected contractor for the Hubbard Street Reconstruction. Similar to other contractors performing work at the same time as the drainage improvements, it is paramount that Comcast complete their conduit installation prior to the Town's roadway construction project, with sufficient time to install the binder pavement course this year.

CPW Engineering Division has reviewed the attached petition from Comcast for the above referenced project in the Town's public ROW and a set of plans (four sheets) titled "Proposed Comcast Underground", dated May 19 2021, prepared for Comcast by Dewsnap Engineering Assoc. LLP. The CPW Engineering Division provides the following conditions and recommendations.

1. In order for the Town to begin the drainage improvements and complete the project by September 2022, Comcast shall begin their work within a month of receiving the CPW's Right of Way Permit. Comcast shall coordinate their work, in a timely manner, with the Town's selected contractor and adhere to the following:

- a. Comcast shall produce a schedule of tasks for CPW to review and approve prior to the beginning of any work.
  - b. Comcast shall not install any new conduits within a 10' radius of the proposed locations for the drainage improvements until the drainage improvements shown on plans prepared by CPW for the Hubbard Street reconstruction have been satisfactorily completed and approved by the Town Engineer. These locations include, but are not limited to, LCB-10, the abandonment of drainage line from CB#27 to CB #28, and pipe repairs along P-28. Comcast shall coordinate this work to ensure the new conduit installation can be completed at the same time or before the drainage improvements are completed.
  - c. Comcast shall maintain the following minimum offsets to the new conduits and vaults:
    - i. Minimum of 7' from proposed leaching catch basin locations
    - ii. Minimum of 3' from all other existing utilities
    - iii. Minimum of 1' vertical separation to any utility crossing
2. The top of conduit shall be installed no less than 30" from the finish grade within the street. An over-dig area within the street shall be installed the length of the trenches, a minimum of 12" in depth and extending 12" on each side of the sides of the trench. The details shall be revised accordingly.
  3. All new vault locations shall be installed within areas of the proposed grass strip along Hubbard St. The locations of the proposed grass strip shall be located using the most current plan of the Hubbard Street reconstruction and can be obtained from the CPW. It is the applicant's responsibility to request the plans and ensure they are the most current prior to installation.
  4. Upon completion of the project, Comcast shall remove their overhead wires currently on the utility poles.
  5. Comcast has submitted stamped construction plans to accompany this Grant of Location request. A ROW Permit application shall be submitted to CPW with revised constructions plans that incorporate CPW Engineering review and stamped by a professional engineer. No work shall commence until CPW has completed its review of the application documents and issues the ROW Permit to Comcast.
  6. As part of the ROW permit, a traffic mitigation plan shall be submitted to the Concord Police Department Traffic Safety Officer and the CPW – Engineering Division for approval.
  7. Contractors shall adhere to the CPW Construction and Tree Protection Standard Operating Procedures including the protection of public shade trees: "No person may



plant, trim, cut, or remove a public shade tree without the prior permission of the Tree Warden and Engineering Division. This control includes the cutting of roots during construction.” The contractor shall be responsible for installing wooden tree guards with orange snow fencing on public shade trees located within the work zone.

8. Generally, all work shall be performed in compliance with the conditions of this memorandum and D.T.E. 98-22. Any modifications to any of the standards set forth in D.T.E. 98-22 shall be requested in writing from the Engineering Division.
9. The contractor must backfill, with suitable backfill material, the trench in 6-inch lifts and compact with mechanical vibratory devices such as vibratory roller, plates, or rammer (pogo stick). Suitable backfill material will mean product meeting the gradation specification for MassDOT M1.03.1 Processed Gravel for sub-base. The gravel material, whether delivered to the site or selected from the spoils, must pass a three (3) inch square mesh sieve and shall not contain frozen material. Contractor must submit material data sheet to Engineering prior to commencing work. No work shall commence until Engineering has completed its review of the material data sheet.
10. Comcast shall have a Geotechnical Engineer verify the material inside the trench and the compaction of the material meets Town of Concord Design and Construction Standards. The results of the analysis shall be submitted to the Engineering Division for review and approval as soon as the analysis is available or weekly whichever comes first.
11. Asphalt (a minimum of 4-inches of binder) patching shall be placed at all trenched locations because the Town will perform full depth reconstruction, but only after Comcast has completed the work under this grant of location.
12. The applicant shall notify emergency services, the school district, the post office, CPW Solid Waste for trash pickup services via email one week prior to the start of construction. The applicant shall also notify neighborhood residents with door hangers one week prior to the start of construction and attend a neighborhood meeting if it is determined to be necessary by CPW.



133 Keyes Road  
Concord, MA 01742



**DATE: 05/27/2021**

**MEMORANDUM**

**TO: Jeremy Romanul, Senior Administrative Assistant**  
**CC: Stephen Crane, Town Manager**  
**VIA: Alan Cathcart, Director of Public Works**  
**FROM: Stephen Dookran PE, Town Engineer**  
**PREPARED BY: Patrick Wood, PE, Public Works Engineer**  
**SUBJECT: Petition from National Grid to relay approximately 1850 feet of 2" CS and 60 feet of 2" PL 60 psi gas main with 1960 feet of new 4" PL 60 psi in Hubbard Street, from Thoreau Street to Walden Street.**

This memorandum is to provide comments to the Select Board on the petition for a Grant of Location filed by National Grid to relay 1960 feet of plastic (PL) main on Hubbard Street. Hubbard Street Reconstruction is part of Concord Public Work's (CPW's) FY2021 Roads Program and is scheduled for full depth reconstruction with funding allotted through municipal funds and a Complete Streets grant. The Town is contractually obligated with the Complete Streets grant to complete the Hubbard Street reconstruction project by September 30, 2022.

The existing 2" gas main - 1850 ft coated steel (CS) and 60 ft PL that runs the entire length of Hubbard Street, from Thoreau Street to Walden Street, on the south easterly side of the right of way (ROW) is to be abandoned in place. Additionally, a new 4" PL main runs the entire length of Hubbard Street, from Thoreau Street to Walden Street, is to be installed with a minimum separation of 3 feet from the old main.

A major goal, and first milestone of the Hubbard Street Reconstruction project, is the stormwater improvements which are required to alleviate the historical flooding along Hubbard St. The drainage system cannot be improved without National Grid coordinating their work with the Town's selected contractor for the Hubbard Street Reconstruction. After completion of the stormwater improvements, the road can be prepared for reclamation and paving. It is paramount that National Grid completes their main replacement prior to the Town's roadway construction project, with sufficient time to install the binder course this year.

CPW Engineering Division has reviewed the attached petition from National Grid for the above referenced project in the Town's public ROW and a set of full sized plans (five sheets) titled "Proposed Gas Main Installation, Hubbard St. Concord, MA", revised May 3, 2021 and prepared for National Grid by CHA. The CPW Engineering Division provides the following conditions and recommendations.

1. In order for the Town to begin the drainage improvements and complete the project by September 2022, National Grid shall begin their work within a month of receiving the CPW's Right of Way Permit. National Grid shall coordinate their work, in a timely manner, with the Town's selected contractor and adhere to the following:

- a. National Grid shall produce a schedule of tasks for CPW to review and approve prior to the beginning of any work.
  - b. If required by CPW, National Grid shall allow CPW accommodations to install drainage structures and pipes where the existing 2” main exists. This access may include, but not limited to looping the gas service or installing temporary bypass lines during drainage structure installation so CPW can complete the installation of drainage improvements.
  - c. National Grid shall not install any new gas main within a 10’ radius of the proposed locations for the drainage improvements until the drainage improvements have been satisfactorily completed and approved by the Town Engineer. These locations include, but are not limited to, the installation of P-25, CB3, DP2 and DMH1. National Grid shall coordinate this work to ensure the new gas main installation can be completed at the same time or before the drainage improvements are completed.
  - d. National Grid shall maintain the following minimum offsets to the new 4” main
    - i. Minimum of 7’ from proposed leaching catch basin locations
    - ii. Minimum of 3’ from all other existing utilities
    - iii. Minimum of 1’ vertical separation to any utility crossing
2. Because the existing main that is to be abandoned is only 2” and its eventual collapse is not expected to cause significant settlement and because Hubbard Street is to be reclaimed no Life Cycle Maintenance Fee (LCMF) will be requested for this project.
  3. National Grid has submitted their stamped construction plans to accompany this Grant of Location request. A ROW Permit application shall be submitted to CPW with constructions plans stamped by a professional engineer. No work shall commence until CPW has completed its review and issues the ROW Permit to National Grid.
  4. National Grid will remove the new 1960-foot 4-inch PL gas main upon completion of its service life.
  5. As part of the ROW permit a traffic mitigation plan shall be submitted to the Concord Police Department Traffic Safety Officer and the CPW – Engineering Division for approval.
  6. Contractors shall adhere to the CPW Construction and Tree Protection Standard Operating Procedures including the protection of public shade trees: “No person may plant, trim, cut, or remove a public shade tree without the prior permission of the Tree Warden and Engineering Division. This control includes the cutting of roots during

construction.” The contractor shall be responsible for installing wooden tree guards with orange snow fencing on public shade trees located within the work zone.

7. Generally, all work shall be performed in compliance with the conditions of this memorandum and D.T.E. 98-22. Any modifications to any of the standards set forth in D.T.E. 98-22 shall be requested in writing from the Engineering Division.
8. The contractor must backfill, with suitable backfill material, the trench in 6-inch lifts and compact with mechanical vibratory devices such as vibratory roller, plates, or rammer (pogo stick). Suitable backfill material will mean product meeting the gradation specification for MassDOT M1.03.1 Processed Gravel for sub-base. The gravel material, whether delivered to the site or selected from the spoils, must pass a three (3) inch square mesh sieve and shall not contain frozen material. Contractor must submit material data sheet to Engineering prior to commencing work. No work shall commence until Engineering has completed its review of the material data sheet.
9. National Grid will have a Geotechnical Engineer verify the material inside the trench and the compaction of the material meets Town of Concord Design and Construction Standards. The results of the analysis shall be submitted to the Engineering Division for review and approval as soon as the analysis is available or weekly whichever comes first.
10. Asphalt (a minimum of 4-inches of binder) patching shall be placed at all trenched locations because the Town will perform full depth reconstruction, but only after National Grid has completed the work under this grant of location.
11. The applicant shall notify emergency services, the school district, the post office, CPW Solid Waste for trash pickup services via email one week prior to the start of construction. The applicant shall also notify neighborhood residents with door hangers one week prior to the start of construction and attend a neighborhood meeting if it is determined to be necessary by CPW.



**PETITION OF NATIONAL GRID FOR GAS MAIN LOCATIONS**

**Town of Concord / Board of Selectmen:**

The Nationalgrid hereby respectfully requests your consent to the locations of mains as hereinafter described for the transmission and distribution of gas in and under the following public streets, lanes, highways and places of the **Town of Concord** and of the pipes, valves, governors, manholes and other structures, fixtures and appurtenances designed or intended to protect or operate said mains and accomplish the objects of said Company; and the digging up and opening the ground to lay or place same:

**Due to Concord's road reclamation, FY20/21 National grid recommends the relay of approximately 1850' of 2" CS (1930) AND 60' OF 2" PL (2010) 60# gas main. With 1910' of 4" PL. 60# in Hubbard St. from Thoreau St to Walden St. Total installation 1910'**

Date: **June 25, 2020**

By: \_\_\_\_\_  
Mary Mulroney  
Permit Representative

**Town of Concord / Board of Selectmen:**

IT IS HEREBY ORDERED that the locations of the mains of the Nationalgrid for the transmission and distribution of gas in and under the public streets, lanes, highways and places of the **Town of Concord** substantially as described in the petition date **June 25, 2020** attached hereto and hereby made a part hereof, and of the pipes, valves, governors, manholes and other structures, fixtures and appurtenances designed or intended to protect or operate said mains and/or accomplish the objects of said Company, and the digging up and opening the ground to lay or place same, are hereby consented to and approved.

The said Nationalgrid shall comply with all applicable provisions of law and ordinances of the **Town of Concord** applicable to the enjoyment of said locations and rights.

Date this \_\_\_\_\_ day of \_\_\_\_\_, 20 \_\_\_\_.

I hereby certify that the foregoing order was duly adopted by the \_\_\_\_\_ of the City of \_\_\_\_\_, MA on the \_\_\_\_\_ day of \_\_\_\_\_, 20 \_\_\_\_.

By: \_\_\_\_\_

\_\_\_\_\_  
Title

**WO # 1340395**

**RETURN ORIGINAL TO THE PERMIT SECTION  
NATIONAL GRID  
40 SYLVAN RD, WALTHAM, MA 02451  
RETAIN DUPLICATE FOR YOUR RECORDS**

# DISTRIBUTION MAIN REPLACEMENT APPROXIMATELY 1960' OF 4" PLASTIC - 60 PSIG 34-183 HUBBARD ST, CONOCRD , MA W.O. NO.: 1340395

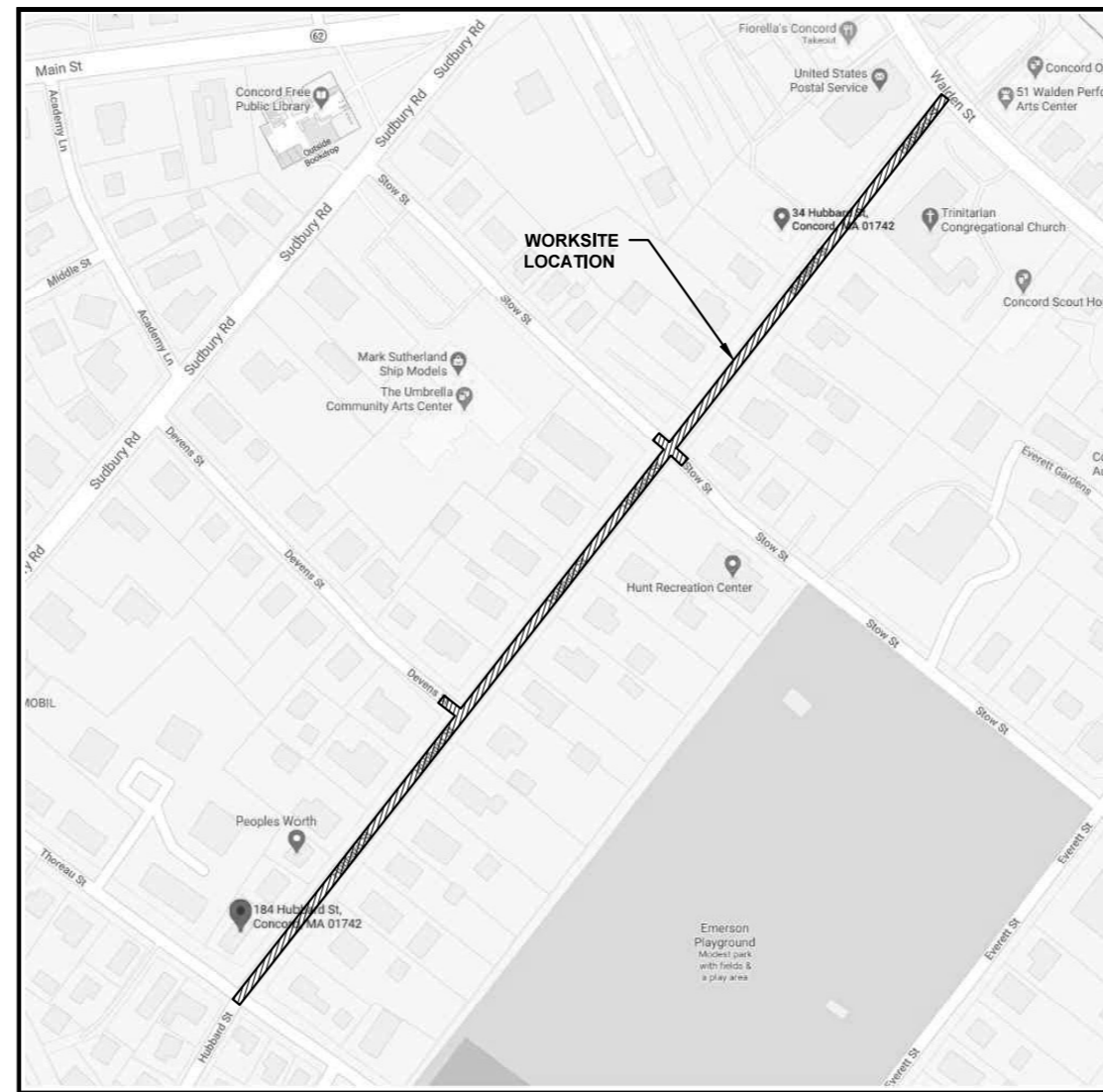

INDEX OF SHEETS		
PAGE	NAME	TITLE
1	DPL-CON-058465-1243 G-001	COVER SHEET
2	DPL-CON-058465-1243 G-002	CONSTRUCTION NOTES AND BOM
3	DPL-CON-058465-1243 C-001	PROPOSED INSTALLATION PLAN
4	DPL-CON-058465-1243 C-002	PROPOSED INSTALLATION PLAN
5	DPL-CON-058465-1243 C-201	PROPOSED TIE-IN DETAILS



LOCUS  
SCALE: NTS



Drawing Copyright © 2021

141 Longwater Drive - Suite 104  
Norwell, MA 02061  
781.982.5400 • www.chacompanies.com



NO.	DESCRIPTION	DATE	DR. BY	CK. BY	APP. BY
2	REVISION	05/03/21	RA	M.R	GWP
1	REVISION	02/03/21	RA	M.R	GWP
0	ISSUED FOR CONSTRUCTION	01/21/21	RA	M.R	GWP

BOSTON GAS COMPANY  
d/b/a  
**nationalgrid**  
40 SYLVAN ROAD  
WALTHAM, MA 02451

FINAL

DWG. SIZE	DESIGNER	ENGINEER	DATE	ASSET I.D.	W.O. NO.:
22"x34"	R.ALABADI	M.RYBINSKI	01/21/2021	DISTRIBUTION	1340395

PAGE 1 OF 5

DRAWING NO.	SHEET NO.
DPL-CON-058465-1243	G-001

NATIONAL GRID  
PROPOSED GAS MAIN INSTALLATION  
HUBBARD ST  
CONOCRD , MA  
**COVER SHEET**

DRAFT

Select Board Calendar 2021

Proposed Summer Schedule

(June 14 no SB Regular meeting; rain date for ATM)

June 21 Regular meeting

June 28 Regular meeting

(July 5 no meeting)

July 12 Regular meeting

July 19 Focused meeting

July 26 Regular meeting

(Aug 2 no meeting)

Aug 9 Regular meeting

Aug 16 Focused meeting

August 23 Regular meeting

(Aug 30 no meeting)

Sep 7 **TUES** Regular meeting

## **Focused Meetings**

### **Potential Topics**

#### **Summer 2021**

Goal Setting Session for SB FY 22 Goals

Town Manager Evaluation

Middle School: Brainstorm Funding, STM, Schematic Design

#### **Autumn 2021**

Diversity Equity Inclusion

Transportation

#### **Early-Mid 2022**

2229 Main Street (may also require Executive Session)

Session with an Executive Coach or Facilitator

Streamlining Committees/ Re-examine app 10 so a person can serve on 2 committees

#### **Try to do at a Regular SB Meeting but may need Focused Meeting**

Town Meeting Follow-up: Articles 7, 41 and Home Rule Petitions

Adopting and Implementing the recommendations of the Capital Planning Task Force

250<sup>th</sup> celebration

#### **Assign to staff**

Green card system improvements

**Select Board 2021-2022  
Committee Liaison Responsibilities**

**Linda Escobedo**

Cemetery Committee  
Community Preservation Committee  
Concord Housing Authority  
Concord Housing Development Corporation  
Concord Municipal Affordable Housing Trust  
HATS  
Historic Districts Commission  
Junction Village Open Space Task Force  
MAPC/Magic  
Planning Board  
Pollinator Health Advisory Committee

**Susan Bates**

Conservation Restriction Stewardship  
Article 7 Personnel Board Placeholder  
Committee  
Commission on Disability  
Concord Center Cultural District Committee  
Concord Local Cultural District  
Council on Aging  
Economic Vitality Committee  
Natural Resources Commission  
Personnel Board  
West Concord Junction Cultural District  
Commission  
White Pond Advisory Committee

**Henry Dane**

Concord 2025 Executive Committee  
Agriculture Committee  
Board of Assessors  
Board of Health  
Board of Registrars  
Library Committee  
MBTA Advisory Committee  
Multi-Town Gas Leaks Initiative  
Peg Access Advisory Committee  
Public Ceremonies and Celebrations  
Committee  
Public Works Commission

**Terri Ackerman**

Capital Planning Task Force  
Citizen Committee to Study Broadband  
Concord Carlisle Regional School Committee  
Concord Public School Committee  
Finance Committee  
Financial Audit Advisory Committee  
Hugh Cargill Trust Committee  
MMA Fiscal Policy Committee  
Tax Relief Committee  
Transportation Advisory Committee  
Trustees of Town Donations

**Matt Johnson**

2229 Main Street Advisory Committee  
Bruce Freeman Rail Trail Advisory Committee  
Climate Action Advisory Board  
Concord Municipal Light Board  
Concord Sustainable Energy Committee  
Historical Commission  
Middle School Building Committee  
NMI/Starmet Property Reuse Committee  
Recreation Committee  
Tax Fairness Committee  
Trails Committee  
Zoning Board of Appeals

## 2020-2021 Select Board Goals

### **Process**

The Concord Select Board annually affirms its values and guiding principles to align its goals and objectives for improving government as it interacts with the Town Manager, committees, task forces, citizens and other units of government. In so doing, the Board aims to lead and establish strategic priorities, to provide support and guidance and encouragement where appropriate and to be collaborative, open and inclusive at all times.

### **Values and Guiding Principles**

Governance: Effective, Responsive and Transparent Governance

Public Health and Safety: Exemplary of Best Practices for the Safety of All

Financial Stability: Fiscal Responsibility and Financial Stability/Sustainability

Infrastructure: Sufficient and Sustainable, Well-maintained and Reliable

Quality of Life: High Level Maintenance of Town Services for Concord Citizens

Balance and Equity: Balance and Equity among divergent individual, neighborhood and town-wide interests

Diversity: Conscious Decision Making to Support Economic and Social Diversity and Inclusion

Historic and Cultural Heritage: Preservation and Promotion of Historic and Cultural Heritage

Agricultural and Natural Resources: Protection and Enhancement

Sustainability and Resilience: Sustainable Management of Energy Resources, Reduction of Carbon Emissions, and Regeneration of Our Natural Environment.

Economic Resilience: To Protect the Vitality of the Town and Businesses

Regional and State Interests: Advancement of Concord's Interest in the Region and the Commonwealth

### **Goals and Objectives**

Specifically, the Board supports short and long-term goals and objectives in the following categories:

#### *Specific to COVID-19 Pandemic*

1. Prioritize public health and public safety in decision making to protect Concord citizens and Town employees during this pandemic period.
2. Implement and monitor evolving State and Federal COVID-19 regulations as they impact municipal operations and guidance for community-wide response.
3. Acknowledge the flexibility required to traditional schedules and procedures to safely respond to the impact of COVID-19 realities on matters before the Select Board and Town, taking extra care with communications to keep everyone informed and encourage engagement.
4. Encourage Town employees and committee volunteers to be mindful of their own well-being during this pandemic as they manage both personal and professional stresses in the continued delivery of quality municipal service to Concord citizens.
5. Work with the Town Moderator to produce a safe, effective, transparent Town Meeting during the COVID-19 pandemic.
6. Support the Economic Vitality Committee and business groups to find creative ways to assist businesses during the COVID-19 pandemic.

### *Effective Governance, Board Organization, and Communication*

1. Provide ongoing support and advice to the Town Manager on leadership opportunities and issues and conduct the annual evaluation of the Town Manager's performance.
2. Continue to support the Town Manager, town departments and town committees as they implement action steps from the *2030 Envision Concord* Comprehensive Long-Range Plan and other new priority areas in their current year goals. Identify and review progress with the Town Manager at the beginning and end of the of the fiscal year. Similarly, oversee the implementation of any additional goals identified by the Select Board.
3. Monitor progress on and approve the final project funding documents between the Town and DHCD for the Christopher Heights ALF at Junction Village.
4. Seat the Junction Village Open Space Task Force and the Concord Municipal Affordable Housing Trust.
5. Provide guidance and resources for all Town volunteers serving on boards and committees to improve consistency and efficiency of public meetings and hearings. Continue training for residents serving on boards and committees.
6. Promote open and transparent government through enhanced use of technology and increased public access television. Review the charter of the PEG Access Advisory Committee in response to rapid changes in video production technology, distribution channels and remote meeting practices.
7. Work to improve citizen communications by implementing a citizen correspondence policy and resume regular publication of a Town Manager's report.
8. Recruit new committee volunteers that reflect all segments of Concord's citizenry; review the Green Card assignment process. Ensure that all volunteers are acknowledged for their willingness to serve.
9. Support and participate in the public review of all new Public Private Partnership Agreements.
10. Review the town's wireless communications policies.

### *Financial Stability*

1. Instill integrated fiscal policies among the Select Board, the Finance Committee, and the School Committee to manage the tax burden on Concord Citizens.
2. Support management of Town services and budgets to maintain Concord's Aaa bond rating and to avoid Proposition 2-1/2 Overrides.
3. Encourage the Capital Planning Task Force to develop a more effective long-term method for understanding and prioritizing the Capital and Facilities needs of the Town and the Schools, to include timetables, cost estimates, and environmental impacts.

### *Balance, Equity and Diversity*

1. Continue to work with our State legislative representatives on special legislation filed for ATM'19 Articles 25 and 26 related to affordable housing.
2. File a request for special legislation for ATM'20 Article 15: Senior Means-Tested Property Tax Exemption and Article 50: Authorize Special Legislation for Additional Liquor Licenses.
3. Submit an ATM'21 warrant appropriation article for affordable housing following recommendations from the Affordable Housing Funding Committee final report to the Select Board.

4. Provide input to the housing production plan update to maximize the equity and diversity impacts of future affordable housing initiatives.
5. Support the Police Department's ongoing implementation of best policing practices that treat all people with dignity and respect, enhance reporting and monitoring, and deescalate volatile situations whenever possible.
6. Assess the capacity of existing Town social service programs to meet the needs of the town population and identify funding.
7. Support proactive planning for wastewater infrastructure, water, telecommunications, energy, parking, traffic, and outdoor lighting.
8. Continue to apply Concord's Sustainability Principles in town decision-making, where appropriate, and seek economic, social and environmental resiliency in both public and private sector development.

*Maintaining Concord's Unique Character, Historic and Cultural Heritage, Agriculture and Natural Resources*

1. Encourage collaboration among town departments for an integrated approach to land use planning to determine priorities, including conservation and acquisition of land to preserve Concord's rural and agricultural culture.
2. Enhance accessibility to recreation and conservation resources in Concord for all citizens.
3. Review and implement recommendations for the recreational use and long-term protection of White Pond and the Gerow land and their ecosystems.
4. Encourage the Natural Resources Department to continue working on and educating the public on the balance needed for general citizen use and dog friendly access, with ecosystem protection in our parks and on conservation lands.
5. Continue to monitor progress on Nagog Pond litigation.
6. Continue to seek resolution for public access to Estabrook Woods; this matter currently being litigated.
7. Launch town-wide planning for events celebrating the 250<sup>th</sup> anniversary of the American Revolution

*Economic Vitality*

1. Promote town events and commercial activity in the village business districts to ensure their continued success.
2. Provide input to the Thoreau Depot business district zoning and development processes.
3. Propose next steps for the Nuclear Metals/Starmet site based upon the recommendations in the committee report.
4. Identify and implement opportunities for transportation throughout town, such as shuttle buses, rail trail and the Assabet River Pedestrian Bridge.
5. Continue to work with the business sector to establish retail diversity support systems including intra- and inter-town transportation.
6. Execute and approve submission of all documents related to ATM'21 Article 16: Tax Increment Financing Agreement and EDIP Local Incentive-Only Application to the Massachusetts EACC.

*Regional and State Interests*

1. Meet regularly with state legislators.

2. Participate in regional organization of which Concord is a member such as HATS, HFAC, MPO, MAPC, MBTA, BRBSB, MAGIC, and Cross-Town Connect.
3. Maintain active relationship with Hanscom AFB.
4. Actively participate in MMA Fiscal Policy Committee.
5. Receive an update on Minuteman Regional Technical High School.

Approved: 10-19-20

## Select Board Goals Action Plan: Discussion/Update December 7, 2020

(items in progress highlighted in blue)

Select Board Goals both guide and are informed by Town Manager and Department Goals.

### Town Manager and Department FY'21 Goals

- Context: Covid-19 Pandemic environment requiring response and adaptation
- TM and Town Departments guided by SB FY'21 Goals
- *Envision Concord 2030* and other goals defined by departments and TM and embedded in FY'21 Approved Budget.
- TM and SMT added goals:
  1. Promote a culture that is respectful and welcoming to all by providing opportunities for employee education, self-reflection and honest conversations on diversity, equity and inclusion issues. Identify and address policies and practices that might negatively impact people of color and/or marginalized groups.
  2. Support employees during COVID19 through policies and programs that promote wellness and work-life balance, so that employees can continue to provide excellent service to the community, including attending to the wellness of Concord's vulnerable populations.
- New initiatives and carryover items on TM's list such as New Transportation Advisory Committee, Cell Tower Coverage for Town Center

### Select Board Action Plan/Outcomes: September 21-December 31, 2020

#### *Specific to Covid-19 Pandemic*

- Agenda items were scheduled in response to new regulations, limiting public ceremonies and events, and supporting economic vitality during this quarter.
- Town Manager updates/reports at SB meetings.
- BOH on agenda to keep public informed.

#### *Effective Governance, Board Organization and Communication:*

- Defined FY'21 Board Goals and Liaison Assignments
- SB members immediately assumed new and continuing roles as committee and community organization liaisons to keep SB informed and support its effectiveness in governance.
- Worked w/ Town Moderator and others immediately to define and approve key dates for warrant, set town meeting date, etc.
- [Still working with Town Manager and others to finalize Official ATM Calendar with election dates](#)
- Ongoing process to prepare for and execute follow-up items for weekly Select Board Meetings, including responsiveness to committee needs and requests (SB has met weekly since March 13, 2020.)

- Reviewed and drafted/codified green card process; [chairs' input needed and revisit document.](#)
- [Request specific action steps for recruitment, consider committee consolidation as opportunity presents itself.](#)
- Responded Legally to OML Complaint: [awaiting outcome](#); working with chairs on OML
- Held initial discussions on improving communications with citizens and the need to resume regular publication of a Town Manager's report; regularly entertain public comment.
- [TM Evaluation to be completed this quarter.](#)
- JVOs Task Force seated [minus one defined seat. AHT to be seated.](#)

## **Select Board Goals Action Plan: Discussion/Update December 7, 2020 (con't)**

### *Financial Stability*

- Fiscal responsibility, budget management, and mindfulness of tax payer burden woven in various SB conversations including reference to Capital Planning Task Force work and upcoming forum, resuming of Middle School Bldg. project, reference to legal expenses, discussion of tax rate certification, etc.

### *Balance, Equity and Diversity*

- The Town Manager and Chair continue to work with our State legislative representatives on special legislation filed for ATM'19 Articles 25 and 26 related to affordable housing.
- Town Manager and Chair filed a request for special legislation for ATM'20 Article 15: Senior Means-Tested Property Tax Exemption and Article 50: Authorize Special Legislation for Additional Liquor Licenses; [a hearing on the latter is scheduled later this week.](#)
- SB supported CPC requests for town projects including funding for the next Housing Production Plan.
- Invited the Police Chief in to discuss best practices and planning for a safe national election cycle.
- Sustainability and Resiliency: Supported CCAB's request with a letter of support to the MA Legislature on an Act Setting Next Generation Climate Policy. [Request to consider new App #63 Fleet Electrification Policy on SB Agenda for December 7.](#)

### *Maintaining Concord's Unique Character, Historic and Cultural Heritage, Agriculture and Natural Resources*

- Enhance accessibility to recreation and conservation resources in Concord for all citizens: Supported Town's CPC submissions
- Review and implement recommendations for the recreational use and long-term protection of White Pond and the Gerow land and their ecosystems: Supported Town's CPC submissions and promoted recent and forthcoming public forums for White Pond.
- Monitoring progress on Nagog Pond Litigation: court activity this quarter.
- Continuing to seek resolution on public access for Estabrook Trail; court activity this quarter.

### *Economic Vitality*

- Promoted town events and commercial activity in the village business districts to ensure their continued success.
- Identify and implement opportunities for transportation throughout town, such as shuttle buses, rail trail and the Assabet River Pedestrian Bridge: [See new December update from Marcia Rasmussen on transportation initiatives.](#)

#### *Regional and State Interests*

- Multiple conversations with state legislators this quarter.
- Represented at MMA Fiscal Policy Committee, HATS, MBTA, Other MMA meetings (and (MAPC?))
- Received an update on Minuteman Regional Technical High School Playing Fields Project and proposed town assessment.

#### **Next Quarter Action Plan Update/Discussion**

1. SB Review entire SB FY'21 Goals Document for next /ongoing priorities including what is already listed below.
2. A finalized Official ATM dictates beginning of town meeting and warrant preparation, preview meeting, etc.
3. BOA presentation to SB on Residential Exemption
4. Presentation/Discussion of Town Manager's FY'22 Budget in response to FinCom guidelines.
5. Update on JV/Christopher Heights Closing status and other agreements
6. Launch and seat a new "coordinating level" committee that oversees the needed structure for the required advanced town-wide planning for the upcoming 250<sup>th</sup> anniversary of the American Revolution.
7. Decision re: this year's April Patriot's Day and related events
8. Receive report from NMI Reuse Planning Committee (timing?)

**From:** Terri Ackerman  
**Sent:** Thursday, June 17, 2021 12:15 PM  
**To:** Linda Escobedo; Susan Bates; Matthew Johnson; Henry Dane  
**Cc:** [janehotchkiss@gmail.com](mailto:janehotchkiss@gmail.com)  
**Subject:** Town Manager Evaluation-Process

Select Board Members:

Since our Town Meeting was late this year, we are already close to the end of FY21. It is already time to think about our annual goal-setting session and the evaluation of the Town Manager.

On June 21, we will be reviewing the SB goals we set last year, and our progress / lack of progress toward achieving them. Please take a look at those goals and be prepared to discuss. (At another meeting in the near future, we will set goals for the upcoming year.)

On June 21 we will also be discussing the process for the upcoming Town Manager evaluation. This will include objectives, forms, timetable, but NOT any discussion of the Town Manager's job performance. To prepare for that discussion, I am attaching the following documents for your review:

- \* Outline of the process items we need to discuss
- \* Evaluation form used in Spring of 2020 and again in late 2020, with proposed modifications in red
- \* Potential additional items from Candidate Profile and Challenge Statement
- \* Memo from HR Director Amy Foley outlining options and sample form for staff input

Thanks in advance. Please do not reply to this message-we will discuss at the June 21 meeting.  
Terri

## Town Manager Evaluation Considerations

### Objectives

- Fair, honest, objective process
- Preserve anonymity of the evaluators
- Comply with OML
- Timely-Goal is to finish before Aug 1
- Useful—not just fluff, praise, criticism. Be specific
- Evaluate how well Manager did on last year's goals (his and ours)
- Set new goals for next year

### Who will evaluate?

- SB from 2020-21
- Self-eval from Town Manager
- SMT feedback, plus Division Managers and TMO
- Feedback from the public

### Form to use

- Modify 2020 form – see attached draft
  - Add section to evaluate how well goals were met from previous year
  - Include goals for next year
  - Add items from Challenge Statement and Candidate Profile?-see attached
  - Shorten the form? (eliminate Sections C and E, since these items are for staff?)
  - Other changes?
- Staff fills out shorter 2-page form- see attached memo from Amy Foley

### Timeline

- Goal-Complete by end of July
- Regular meeting or Focused meeting?



**TOWN OF CONCORD**  
**HUMAN RESOURCES DEPARTMENT**  
TOWN HOUSE  
P.O. BOX 535  
22 MONUMENT SQUARE  
CONCORD, MASSACHUSETTS 01742

TEL: 978-318-3025  
FAX: 978-318-3024  
[hr@concordma.gov](mailto:hr@concordma.gov)

June 16, 2021

To: Terri Ackerman, Concord Select Board

From: Amy Foley, Human Resources Director 

Subject: Town Manager Evaluation – Options for Obtaining Staff Feedback

This memo outlines ideas you and I discussed at our recent meetings in which we explored options for soliciting feedback from staff relative to the Town Manager's performance.

My understanding is that you seek a process/tool that:

- obtains feedback from the Senior Management Team and other employees who regularly work with the Town Manager;
- is fair, aids the Select Board in evaluating the Town Manager's performance, and assists in identifying professional development goals;
- protects anonymity of respondents;
- has limited costs involved; and
- can be completed within a few weeks.

The attached documents were prepared with those objectives in mind.

Once the Select Board has identified the approach that will be used this year, I would be happy to assist you in finalizing any customized content and implementing the staff feedback tool.

**Options Identified for Soliciting Staff Feedback**  
**2021 Town Manager Evaluation**

**1. Concord-Designed Paper Form**  
**(see attached sample)**

<b>Pros:</b>	<b>Cons:</b>
<ul style="list-style-type: none"> <li>• Customizable – can match to Concord’s needs and goals</li> <li>• Easy for respondents to use</li> <li>• Provides option to not save completed form on respondent’s computer (print only)</li> <li>• Protects anonymity/confidentiality of respondent when handled correctly</li> <li>• Minimal costs involved</li> </ul>	<ul style="list-style-type: none"> <li>• Requires distribution of pre-addressed envelope if goal is to ensure all responses look the same</li> <li>• Respondents must follow detailed instructions (printing response and delivering to specific location)</li> <li>• If respondents don’t follow instructions, anonymity of others diminished</li> <li>• If Select Board Chair doesn’t handle compilation and reporting carefully, anonymity could be compromised</li> <li>• May require purchase of lock box (~\$35)</li> </ul>

**2. Concord-Designed On-line Survey using Survey Monkey**  
**(same approach to questions as reflected in paper option)**

<b>Pros:</b>	<b>Cons:</b>
<ul style="list-style-type: none"> <li>• Customizable – can align to Concord’s defined expectations and goals</li> <li>• Distribution is quick and easy</li> <li>• Easy for respondents to use</li> <li>• Easy response submittal – doesn’t require time for logistics</li> <li>• Data/trends can be compiled and reported on easily in varied forms</li> <li>• Paperless submittals</li> <li>• Doesn’t store responses on each computer</li> <li>• Can be set-up to collect responses anonymously</li> <li>• No cost if HR account used</li> </ul>	<ul style="list-style-type: none"> <li>• License must be purchased for Select Board Chair if HR not involved (\$384 annually)</li> <li>• Responses would be visible to HR Director or Asst. HR Director if staff account is used or Chair needs assistance</li> <li>• Some staff may not trust anonymity/confidentiality of electronic format</li> </ul>

**3. 360-degree Assessment Product Used by ICMA Credentialed Managers  
(e.g., University of Georgia’s GOV360 or Concord Consulting’s Leadership Assessment Tools)**

<b>Pros:</b>	<b>Cons:</b>
<ul style="list-style-type: none"> <li>• Ready-to-go</li> <li>• Distribution is quick and easy</li> <li>• Easy for respondents to use</li> <li>• Easy response submittal – doesn’t require time for logistics</li> <li>• Vendor compiles and reports data</li> <li>• Paperless submittals</li> <li>• Responses not saved to staff computers</li> <li>• Town receives compiled results vs. individual responses</li> <li>• Responses are anonymous except where a narrative response provides identifying information</li> </ul>	<ul style="list-style-type: none"> <li>• Cost (\$150 - \$225) for assessment tool</li> <li>• Designed to be a professional development tool that provides feedback to the Manager, not supervisors</li> <li>• Doesn’t provide ability to customize and match to the performance criteria and goals identified by the Town; might not provide the information most relevant to the Town’s and Manager’s needs</li> </ul>

**4. Customizable 360-degree Assessment Product offered by Concord Consulting**

<b>Pros:</b>	<b>Cons:</b>
<ul style="list-style-type: none"> <li>• Ready-to-go product that also provides ability to customize by adding or removing questions/competencies</li> <li>• Distribution is quick and easy</li> <li>• Easy for respondents to use</li> <li>• Easy response submittal – doesn’t require time for logistics</li> <li>• Vendor compiles and reports data</li> <li>• Paperless submittals</li> <li>• Responses not saved to staff computers</li> <li>• Town receives compiled results vs. individual responses</li> <li>• Anonymous, except where a narrative response provides identifying information</li> </ul>	<ul style="list-style-type: none"> <li>• Cost to customize is \$500</li> <li>• Degree of customization needs further exploration</li> </ul>

**SAMPLE CUSTOMIZED FORM**

Town of Concord, MA

**Town Manager Performance Feedback  
SMT, Division Manager & TM Office Staff Input**

**Instructions:**

**Please only complete this form if you have had regular opportunities to work with the Town Manager within the past 12 months.**

To protect the anonymity of all respondents, please:

- Type your responses to this form using Word, rather than handwriting.
- Do not identify your name, department, or title.
- Do not email your response.
- Once completed, print the form, seal it in the attached pre-addressed envelope without adding your identifying information, and deposit it in the secure lockbox located \_\_\_\_\_. Only the Select Board Chair has the key to the drop box and will view responses.

**Please deposit your response in the drop box no later than 4:00 p.m. on \_\_\_\_\_.**

**Questions:**

Are you a member of the Senior Management Team?

YES                       NO

<b>In your opinion, to what degree does the Town Manager:</b>	<b>Consistently – Clear Strength</b>	<b>Usually – Effective Level</b>	<b>Inconsistently – Needs Some Development</b>	<b>Rarely or Never – Needs Significant Development</b>	<b>Unknown / Not Applicable</b>
Work effectively with your department/division.					
Nurture and embrace an established positive culture while promoting civility and professional decorum in all public discourse.					
Lead, organize, inspire and manage staff.					
Demonstrate passion, energy, commitment to excellence, and a “can-do” attitude to guide Concord into the next decade.					
Work hard to become informed about the operations, incidents, and developments within your department/division.					
Demonstrate increasing knowledge of Concord and of town operations.					
Make decisions and deliberate in a manner that demonstrates an understanding of Concord’s operations, culture, and values.					
Advise you of Select Board agenda items relevant to your position and discuss them with you in advance to obtain relevant input/information.					
Demonstrate an open mind, asking questions and listening closely before making a decision.					
Demonstrate that he listens closely to staff, Select Board members, and community voices, including those that he is not inclined to agree with.					
Solicit feedback to gauge the effectiveness of his working relationships and to learn of suggestions for improvement.					

Ensure that you are informed of and engaged as appropriate in any major organizational change impacting your position.					
Engage the SMT and staff in supporting and implementing Select Board policies, directives, and goals.					
Advise department/division heads of external and internal developments that impact or could influence operations.					
Understand department/division needs, operations, accomplishments, and challenges, and accurately relay in public forums as appropriate.					
Provide professional direction to staff based on appropriate study and analysis.					
Maintain a professional working relationship with staff promoting a climate of mutual respect and trust.					
Inspire others to highest professional standards.					
Assure the safe and efficient operation of Town departments.					
Administer the Town in accordance with laws, the Town Charter, rules, regulations, and the Town's policies.					
Delegate responsibility effectively and appropriately.					
Establish and maintain effective channels of communication.					
Ensure departments have tools needed to adequately maintain records, including a system of financial accounts, business and property records, and personnel records.					
Understand your department budget requests/needs and represent appropriately.					
Provide creative management of available resources to increase productivity and economy.					
Establish sound personnel procedures and practices including those for hiring, promotion, and separation that provide Town departments with strength and stability.					
Recruit and appoint for employment the best qualified and most competent personnel.					
Approach personnel decisions in a non-discriminatory and impartial manner and be alert to those issues which affect staff morale.					
Actively support a meaningful staff evaluation program which contributes to professional growth of personnel.					
Provide for a meaningful and balanced staff development program.					
Provide for the dissemination and interpretation of Town policies to staff members.					
Demonstrate knowledge and experience in negotiations within a collective bargaining environment while also maintaining the ability to establish respectful and harmonious relationships with union and non-union leadership within the organization. Apply effective approaches to bargaining of union contracts.					
Develop good staff morale and loyalty to the organization.					
Effectively communicate the mission and accomplishments of the Town to staff and the community.					
Demonstrate impeccable professional and personal ethical standards, integrity, respect, honesty and accountability. Inspire others to highest					

professional standards					
Express ideas in a logical and forthright manner, both verbally and in written form.					
Encourage open communication with staff, the public and Select Board.					
Follow through on plans and decisions to ensure effective implementation through action.					
“Listen” and empower various constituents in the local government to help provide the highest level of customer service and professional results.					
Promote continuous improvement and excellence in the delivery of public services with a strong emphasis in the utilization of evolving IT innovations to improve communications and build added efficiencies in the delivery systems of the community through the thoughtful use of all the latest “best management” practices for local government excellence.					

**Open Response:**

**Please consider providing comments regarding the Town Manager’s strengths, skills, accomplishments, impacts on the organization, opportunities for improvement and any other information you think relevant to his evaluation.**

A. Goals from Previous Year

1. The Town Manager will continue to regularly and frequently inform the Select Board and keep them fully apprised about key town operations, incidents, and developments. This is particularly important for high visibility issues as well as for key developments that pertain to Select Board members' liaison assignments.

2. The Town Manager will strive to improve his depth of knowledge of Concord and of town operations. The Select Board expects the Town Manager to diligently pursue a more complete understanding of town operations and the Concord community as a whole and for this to be evident in his decisions and deliberations.

3. The Town Manager will ensure that the Select Board always receives a complete and accurate meeting packet by Friday for each Monday meeting. Furthermore, he is advised to pro-actively preview each agenda item in advance with regard to OML, Town policies, Town Counsel review, etc., giving guidance to the Select Board chair as needed. The Town Manager needs to be prepared for his weekly Town Manager's report and have already discussed with his appropriate staff member(s) weekly Select Board agenda items. Acknowledging attribution for staff content contributions is important.

4. The Town Manager will work hard to keep an open mind, asking questions and listening closely before making a decision. He will make a habit of listening closely to staff, Select Board members, and community voices, including those that he is not inclined to agree with. He will implement Select Board decisions faithfully and bring issues back to the board if any revisions are required.

5. Within the next few months, the Town Manager is strongly encouraged to solicit feedback from the SMT via the HR Director to gauge the effectiveness of his working relationship with his team and to solicit suggestions for improvement.

6. Regarding Personnel Management, the Town Manager will inform the Select Board on issues such as collective bargaining strategy and progress, significant personnel changes at the SMT level, and any planned major organizational change.

Consistently Exceeds Expectations	Consistently meets & occasionally exceeds expectations	Meets Expectations	Needs Improvement	Does not Meet Expectations	Cannot Evaluate

Formatted Table

Formatted: Left, Right: -0.5"

Formatted: Indent: Left: 0.21", Right: 4.2", No bullets or numbering

Formatted: Right: 4.2"

A.B. Relationship with the Board of Selectmen

1. Accomplishes goals and objectives established for the year.
2. Interprets, supports and implements policies and directives of Board.
3. Works well with the chair to establish clear direction for Selectmen meetings by providing agendas and support material that allow for reasonable policy formation and decision making.
4. Keeps Board informed on issues, needs and operation of the Town departments.
5. Offers professional advice to the Board on items requiring action, with appropriate recommendations based on thorough study and analysis.
6. Fully informs the Board of the implications of all major personnel and program changes.
7. Provides Board with pertinent and timely information regarding performance of Town operations
8. Maintains a professional working relationship with the Board promoting a climate of mutual respect and trust

Consistently Exceeds Expectations	Consistently meets & occasionally exceeds expectations	Meets Expectations	Needs Improvement	Does not Meet Expectations	Cannot Evaluate

Formatted Table

Strengths and, Weaknesses:

Suggested Goals for the Upcoming Year:

B.C. Leadership

1. Effectively implements the policies of the Board of Selectmen and relevant decisions of Town Meeting.
2. Keeps abreast of the latest developments in government regulation and legislation and advises the Board as to possible local influence and impact.
3. Inspires others to highest professional standards.
4. Prepares annual and interim reports on continuing programs and issues of concern.

Consistently Exceeds Expectations	Consistently meets & occasionally exceeds expectations	Meets Expectations	Needs Improvement	Does not Meet Expectations	Cannot Evaluate

Formatted Table

Strengths and Weaknesses:

Suggested Goals for the Upcoming Year:

Strengths, Weaknesses, Suggested Goals

C.D. General Management

1. Assures the safe and efficient operation of Town departments.
2. Administers Town departments in accordance with the state and federal laws, the Town Charter and Bylaws, Standing Votes, Rules and Regulations, and Administrative Policies and Procedures.
3. Delegates responsibility effectively and appropriately.
4. Establishes and maintains channels of communication.
5. Maintains adequate records for the Town departments, including a system of financial accounts, business and property records and personnel records.
6. Manages his time so he can give proper attention to those priorities established by him and the Board.

Consistently Exceeds Expectations	Consistently meets & occasionally exceeds expectations	Meets Expectations	Needs Improvement	Does not Meet Expectations	Cannot Evaluate

Formatted Table

Commented [ta1]: ? Eliminate most of this section, since these items are on the Staff form?

Strengths and Weaknesses:

Suggested Goals for the Upcoming Year:

~~Strengths, Weaknesses, Suggested Goals~~

D.E. Budget Management

1. Coordinates preparation of the annual budgets.
2. Presents the budgets to the Selectmen in a manner which promotes their full understanding.
3. Expends Town Meeting-approved budgets through effective use of budget forecasting, accounting and control systems.
4. Provides creative management of available resources to increase productivity and economy.
5. Recommends annual operating goals and objectives for the Town.

Consistently Exceeds Expectations	Consistently meets & occasionally exceeds expectations	Meets Expectations	Needs Improvement	Does not Meet Expectations	Cannot Evaluate

Formatted Table

Strengths and Weaknesses:

Suggested Goals for the Upcoming Year:

~~Strengths, Weaknesses, Suggested Goals~~

E.F. Personnel Management

1. Establishes sound personnel procedures and practices including those for hiring, promotion, and separation that provide Town departments with strength and stability.
2. Recruits and appoints for employment the best qualified and most competent personnel.
3. Approaches personnel decisions in a non-discriminatory and impartial manner and is alert to those issues which affect staff morale.
4. Actively concerned with a meaningful staff evaluation program which contributes to professional growth of personnel.
5. Provides for a meaningful and balanced staff development program.
6. Informs and advises the Selectmen in appropriate matters of collective bargaining and grievance hearings.
7. Provides for the dissemination and interpretation of Town policies to staff members.
8. Conducts all collective bargaining and keeps Selectmen informed prior to recommending contract approval.
9. Develops good staff morale and loyalty to the organization.

Consistently Exceeds Expectations	Consistently meets & occasionally exceeds expectations	Meets Expectations	Needs Improvement	Does not Meet Expectations	Cannot Evaluate

Formatted Table

Commented [ta2]: ? Eliminate this section, since these items are on the Staff form?

Strengths, Weaknesses, Suggested Goals

Strengths and Weaknesses:

Suggested Goals for the Upcoming Year:

F. Communications and Public Relations

1. Communicates the mission and accomplishments of the Town to staff and community.
2. Seeks to achieve community understanding of the goals of the Town.
3. Understands the needs and aspirations of the community.
4. Solicits and gives attention to the perspectives of various groups and individuals on community issues.
5. Encourages community involvement in Town activities and volunteer government and interacts with residents and community groups.
6. Works effectively with representatives of Town departments, state agencies and officials, community leaders and local non-profit agencies.
7. Develops good relationships with the news media.

Consistently Exceeds Expectations	Consistently meets & occasionally exceeds expectations	Meets Expectations	Needs Improvement	Does not Meet Expectations	Cannot Evaluate

Formatted Table

Strengths and Weaknesses:

Suggested Goals for the Upcoming Year:

~~Strengths, Weaknesses, Suggested Goals~~

Formatted: Indent: Left: 0"

G. Personal Qualities and Characteristics

1. Maintains high standards of ethics, honesty and integrity in personal and professional matters.
2. Expresses ideas in a logical and forthright manner, both verbally and in written form.
3. Encourages open communication with staff, the public and Selectmen.
4. Represents the Town in a professional manner at meetings within the town, in regional governmental agencies, and at the state level.
5. Exhibits the necessary health and energy to meet the responsibilities of the position.
6. Maintains personal professional development.
7. Follows through on plans and decisions to ensure effective implementation through action.

Consistently Exceeds Expectations	Consistently meets & occasionally exceeds expectations	Meets Expectations	Needs Improvement	Does not Meet Expectations	Cannot Evaluate

Formatted Table

Strengths and Weaknesses:

Suggested Goals for the Upcoming Year:

~~Strengths, Weaknesses, Suggested Goals~~

## Potential additional items from Candidate Profile and Challenge Statement

As part of the Town Manager search process, stakeholders' input was used to develop an Ideal Candidate Profile and Challenge Statement that was published and provided to candidates. The Select Board may want to consider incorporating some of these elements into the form the Board members use to evaluate the Town Manager's performance:

In your opinion, to what degree does the Town Manager:	Consistently – A Strength	Usually – Acceptable	Rarely – Needs Improvement	Never – Unmet Need	Unknown / Not Applicable
Demonstrate thoughtful, creative financial budget management as well as strategic capital planning skills.					
Consider input received from elected and appointed officials, and of constituent needs, while formulating budgets and plans.					
Collaborate and deliberate in a manner that allows for community involvement by an active, engaged, knowledgeable and diverse citizenry.					
Demonstrate ability to be intellectually challenged in problem solving complex issues and to identify innovative solutions and build consensus while allowing for diversity of opinions from all affected parties.					
Demonstrate strong public speaking and presentation skills.					
Demonstrate knowledge and experience in negotiations within a collective bargaining environment while also maintaining the ability to establish respectful and harmonious relationships with union and non-union leadership within the organization.					
“Listen” and empower various constituents in the local government to help provide the highest level of customer service and professional results.					
Promote continuous improvement and excellence in the delivery of public services with a strong emphasis in the utilization of evolving IT innovations to improve communications and build added efficiencies in the delivery systems of the community through the thoughtful use of all the latest “best management” practices for local government excellence.					
Nurture and embrace an established positive culture while promoting civility and professional decorum in all public discourse.					
Demonstrate ability to provide unbiased guidance to all elected and appointed officials as well as an engaged and diverse citizenry.					
Manage Town affairs in an open, diplomatic and transparent manner.					
Lead, organize, inspire and manage staff.					
Multi-task a myriad of complex issues while remaining focused on Select Board priorities.					
Work collaboratively and cooperatively; build consensus with a strong emphasis on maintaining a positive, productive relationship between the School and Municipal Administrations.					
Demonstrate impeccable professional and personal ethical standards, integrity, respect, honesty and accountability.					
Earn the respect and confidence of the community.					

Establish positive internal as well as external relationships.					
Hold himself to the highest professional standards of integrity and accountability.					
Builds consensus as a skilled collaborator/facilitator and persuasive negotiator; guide groups to meet collective needs of the community and annual goals of the Select Board.					
Value SMT and maintain positive working relationships within the group; coach and mentor as needed.					
Maintain confidence of the residents in quality and value of service received in relation to taxes paid.					
Support budget and real estate sustainability.					
Develop and maintain good working relationship with Superintendent.					
Manage fair and reasonable collective bargaining agreements for both sides while balancing union and non-union employees' needs with the Town's ability to pay.					
Lead ecological resilience and actively commit to the Town's climate and sustainability goals.					
Demonstrate strong familiarity with the Comprehensive Long Range Plan, its goals and recommendations/actions; use it as a guiding light for administration.					
Demonstrate keen awareness of housing affordability problems and work with boards to develop options for the community.					
Remain aware of and sensitive to the tourism economy, and build on it. Work with businesses, not-for-profits, and Chamber of Commerce to promote growth and prosperity in the community.					
Aid in conflict resolution.					
Approachable leader.					
<hr/> Ability to respond quickly and decisively to unexpected circumstances.					
Respects Concord's traditions/governance model/deliberation process and aligns his management style with these values.					
Demonstrate passion, energy, commitment to excellence, and a "can-do" attitude to guide Concord into the next decade.					

# WEST CONCORD UNION CHURCH



AN OPEN AND AFFIRMING CONGREGATION  
OF THE UNITED CHURCH OF CHRIST

1317 Main Street, Concord, MA 01742 • [WestConcordUnionChurch.org](http://WestConcordUnionChurch.org) • 978-369-6309

To: Concord Select Board Chair Linda Escobedo; Select Board Clerk Susan Bates; Select Board Members Terri Ackerman, Jane Hotchkiss, and Matthew Johnson

Subject: Diversity, Equity, and Inclusion in Concord

Date: June 4, 2021

Dear Ms. Escobedo and Members of the Concord Select Board,

West Concord Union Church writes in support of the League of Women Voters of Concord-Carlisle's request that the Town of Concord establishes a Diversity, Equity, and Inclusion Commission to assess, address, and proactively move our community forward on these issues. We agree that, while the Concord-Carlisle School Committee has recently hired a DEI Director, this action is only the first step in the right direction because we need to reflect, consider, and create plans to make a difference on a town-wide basis.

In our Open and Affirming statement, the members of West Concord Union Church are called to love one another as God loves us, freely and unconditionally. We further believe that diversity enriches our faith community. Therefore, we welcome persons of any sexual orientation, gender identity and expression, age, race, socio-economics status, ethnicity, and physical and mental ability into full membership and participation in the body of Christ. In light of our commitment to our faith community, we hope to inspire the Town of Concord to embrace this moment in history, as our nation confronts its legacy of the original sin of slavery and its continued manifestation in the fabric of our society.

We hope that you will give the proposed Diversity, Equity, and Inclusion Commission the time and attention it deserves in July after the Town Meeting.

Sincerely yours,

Hannah Brown  
Pastor

Matthew J. DeGreeff  
Moderator

Andrew Southcott  
Clerk

Cc: Julie Rohwein, President, League of Women Voters Concord-Carlisle

June 1, 2021

To the Select Board of Concord,

We are writing in support of the League of Women Voters request to the Select Board regarding Diversity, Equity and Inclusion in Concord.

Following the example and inspiration of other organizations in our community, First Parish in Concord urges the town of Concord to proactively assess and address the issues of Diversity, Equity and Inclusion.

We urge the Select Board to charter a commission charged with making recommendations on policies and programs which identify and seek to eliminate conscious or unconscious biases and prejudices and increase inclusion of historically disenfranchised demographic groups within our community.

We thank you for your service to Concord in furtherance of our mutual goals to promote a just and more equitable community.

Sincerely,

A handwritten signature in blue ink, consisting of a large, stylized initial 'P' followed by a long horizontal line.

Peter Nobile, Chair

On behalf of the Standing Committee

First Parish in Concord

## Jeremy Romanul

---

**From:** tbartevyan <tbartevyan@yahoo.com>  
**Sent:** Friday, June 18, 2021 11:53 AM  
**To:** Terri Ackerman; Susan Bates; Linda Escobedo; Matthew Johnson; Henry Dane; Jeremy Romanul  
**Cc:** Mark Gailus; Diane Proctor; julie rohwein; K Reed; Kaari Tari  
**Subject:** In person/Virtual/Hybrid meetings

Dear Members of the Select Board,

Re: your agenda item 7 for June 21, 2021:  
"Discuss Upcoming Meetings: In-Person, Virtual, Hybrid"

Please make sure that whatever venue the Select Board uses for its own purposes is also available to the public.

In other words, if you meet in person, please allow that the public can attend in person, too.

Zoom capability for those who want to attend - whether Board members or the members of the public- is of course an added bonus.

One of the weak points of the Governor's emergency regulations was the possibility for a Board to meet in person while allowing the public only remote access. This may have made sense during times of high COVID danger, especially when Boards were also meeting remotely. It is disappointing that this provision has not been amended to now provide that the public should be able to attend in the same manner that a Board utilizes.

Another benefit the public misses from remote meetings is the ability to connect with each other during in person meetings (even if public comment is at the discretion of the Chair.) For this reason, please allow as much public comment as possible.

Thank you for your consideration.

A welcome to Mr. Dane to the Select Board, and best wishes to you all,

Tanya B. Gailus