

# Stormwater Management Report

## NOVO Riverside Commons

**292-294 Baker Avenue  
Concord, Massachusetts**

*Prepared for:*  
**NOVO Riverside Commons, LLC**

*Prepared by:*



**September 19, 2023**

*Calculated by:* **Thomas J. Michalak, PE**

*Checked by:* **Daniel M. Feeney, PE**

*Approved by:*

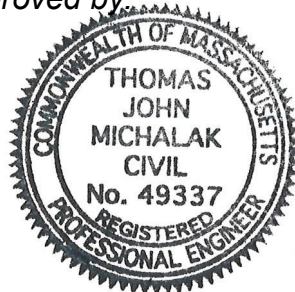

9/19/2023



Thomas J. Michalak, PE

**TABLE OF CONTENTS**

**1.0 INTRODUCTION ..... 1**

    1.1 EXECUTIVE SUMMARY ..... 1

**2.0 PRE-DEVELOPMENT CONDITIONS ..... 3**

    2.1 SITE CONDITIONS ..... 3

    2.2 SOIL DESCRIPTION ..... 3

    2.3 HYDROLOGIC ANALYSIS ..... 4

**3.0 POST-DEVELOPMENT CONDITIONS ..... 5**

    3.1 DESIGN STRATEGY ..... 5

    3.2 HYDROLOGIC ANALYSIS ..... 6

    3.3 STORMWATER MANAGEMENT CONTROLS SIZING ..... 6

    3.4 HYDRAULIC CALCULATIONS ..... 6

    3.5 COMPLIANCE WITH DEP STORMWATER MANAGEMENT STANDARDS ..... 7

    3.6 ILLICIT DISCHARGE COMPLIANCE STATEMENT ..... 11

**LIST OF ATTACHMENTS**

- ATTACHMENT 1: SOIL DATA
- ATTACHMENT 2: PRE-DEVELOPMENT HYDROLOGIC ANALYSIS
- ATTACHMENT 3: POST-DEVELOPMENT HYDROLOGIC ANALYSIS
- ATTACHMENT 4: FLOODPLAIN & PROPOSED COMPENSATORY STORAGE ANALYSIS
- ATTACHMENT 5: RECHARGE/DRAWDOWN, WATER QUALITY, TSS & SIZING CALCULATIONS
- ATTACHMENT 6: SITE OWNER’S MANUAL

## 1.0 INTRODUCTION

### 1.1 Executive Summary

The project site is located at the existing 300-310 Baker Avenue site in Concord. The Applicant is proposing two residential apartment buildings be constructed along the southern portion of the 300-310 Baker Avenue property on a new 10.2 acre parcel. The overall site currently consists of a general office building and associated parking areas. Stormwater runoff ultimately flows to the Assabet River which abuts the property to the south and west. Portions of the existing development fall within the 100-Year Floodplain of the Assabet River.

The project has been designed in accordance with:

- The 2008 Massachusetts Department of Environmental Protection (DEP) Stormwater Management Handbook,
- The Massachusetts Wetland Protection Act (310 CMR 10.00), and
- The Concord Wetlands Bylaw (where practicable)

The pre- and post-development hydrologic conditions were modeled using HydroCAD™ version 8.00 to demonstrate that post-development stormwater runoff rates will be less than or equal to the pre-development rates. Watershed maps with soil types as well as detailed analysis of the model results are also included. The following tables summarize the peak runoff rates and volumes for the pre and post-development conditions to the respective design points. Design points DP-1, 2 & 3 are interim design points, interior to the site; design points DP-4, 5, & 6 are ultimate design points, where runoff discharges from the development area. Peak rates of runoff are attenuated at the respective ultimate design points.

Table 1: Pre- & Post-development Peak Runoff Rate Comparison, units are in cubic feet per second (cfs).

| Storm Event | 2-Year     |      | 10-Year    |      | 25-Year    |       | 100-Year   |       |
|-------------|------------|------|------------|------|------------|-------|------------|-------|
|             | <i>Pre</i> | Post | <i>Pre</i> | Post | <i>Pre</i> | Post  | <i>Pre</i> | Post  |
| DP-1        | 2.77       | 3.00 | 7.98       | 7.03 | 12.77      | 10.66 | 23.52      | 20.54 |
| DP-2        | 0.07       | 0.23 | 0.21       | 0.46 | 0.21       | 1.04  | 0.23       | 1.81  |
| DP-3        | 0.70       | 0.38 | 1.53       | 0.98 | 2.23       | 1.41  | 3.72       | 2.24  |
| DP-4        | 0.28       | 0.13 | 0.68       | 0.21 | 1.03       | 0.27  | 1.79       | 0.39  |
| DP-5        | 0.70       | 0.58 | 1.54       | 1.26 | 2.26       | 1.90  | 3.87       | 3.68  |
| DP-6        | 0.98       | 0.64 | 2.21       | 1.40 | 3.29       | 2.03  | 5.67       | 3.95  |

Table 2: Pre- & Post-development Runoff Volume Comparison, units are in acre-feet.

| Storm Event | 2-Year       |       | 10-Year      |       | 25-Year      |       | 100-Year     |       |
|-------------|--------------|-------|--------------|-------|--------------|-------|--------------|-------|
|             | <i>Pre</i>   | Post  | <i>Pre</i>   | Post  | <i>Pre</i>   | Post  | <i>Pre</i>   | Post  |
| DP-1        | <i>0.355</i> | 0.322 | <i>0.881</i> | 0.726 | <i>1.370</i> | 1.139 | <i>2.491</i> | 2.133 |
| DP-2        | <i>0.097</i> | 0.222 | <i>0.348</i> | 0.529 | <i>0.394</i> | 0.716 | <i>0.447</i> | 0.950 |
| DP-3        | <i>0.056</i> | 0.060 | <i>0.118</i> | 0.110 | <i>0.173</i> | 0.152 | <i>0.292</i> | 0.243 |
| DP-4        | <i>0.023</i> | 0.010 | <i>0.053</i> | 0.017 | <i>0.080</i> | 0.022 | <i>0.140</i> | 0.034 |
| DP-5        | <i>0.152</i> | 0.282 | <i>0.466</i> | 0.640 | <i>0.567</i> | 0.869 | <i>0.739</i> | 1.193 |
| DP-6        | <i>0.176</i> | 0.292 | <i>0.519</i> | 0.657 | <i>0.647</i> | 0.891 | <i>0.879</i> | 1.226 |

## 2.0 PRE-DEVELOPMENT CONDITIONS

### 2.1 **Site Conditions**

The proposed 10.2-acre parcel is partially developed with parking areas and site driveways serving for the 300-310 Baker Avenue office building. The western portion of the parcel consists of bordering vegetated wetlands (BVW) associated with the Assabet River. A pond and associated BVW are located within the central portion of the site. Stormwater from the existing paved parking areas is collected in catch basins and discharged to onsite wetland pond with minimal treatment of stormwater.

### 2.2 **Soil Description**

The Natural Resources Conservation Service (NRCS) lists the on-site soils as:

#### Rippowam Fine Sandy Loam

A poorly drained soil consisting of 80% Rippowam, 10% Saco, 5% Pootatuck, and 5% Limerick component materials. Generally, this soil is located on alluvial flats on alluvial plains, with layers of fine sandy loam, sandy loam, and stratified sand to fine sand to 65 inches below the surface. Parent material consists of loamy alluvium over sandy and gravelly alluvium derived from granite and gneiss. NRCS classifies this type of soil as dual-hydrologic class HSG A/D (upland/wetland, for the purposes of this analysis).

#### Hinckley Loamy Sand

An excessively drained soil consisting of 80% Hinckley, 8% Merrimac, 5% Windsor and 2% Sudbury. Generally, this soil is located on kames on valleys, and has layers of loamy sand and gravelly loamy sand to 19 inches below the surface. Very gravelly sand parent material consists of sandy and gravelly glaciofluvial deposits derived from gneiss and/or granite and/or schist. NRCS classifies this type of soil as hydrologic class HSG A.

#### Merrimac-Urban Land Complex

A somewhat excessively drained soil consisting of 45% Merrimac, 40% Urban Land, 5% Windsor, 5% Sudbury, and 5% Hinckley. Generally, this soil is located on outwash terraces on outwash plains, and has layers of fine sandy loam, stratified gravel to gravelly sandy loam to 26 inches below the surface. Stratified gravel to very gravelly sand parent material consists of loamy glaciofluvial deposits derived from granite, schist, and gneiss over sandy and gravelly glaciofluvial deposits derived from granite, schist, and gneiss. NRCS classifies this type of soil as hydrologic class HSG A.

#### Urban Land & Udorthents

NRCS does not provide a hydrologic soil classification for these soils. Given the adjacent soils, these soils were conservatively assumed to be hydrologic soil class HSG A.

### 2.3 Hydrologic Analysis

Sub-catchment areas were delineated based on existing runoff patterns and topographic information. This information is shown on the *Pre-Development Conditions Hydrologic Areas Map* included in Attachment 2. Summaries of each area with respect to Curve Number and Time of Concentration calculations can be found in the model results also in Attachment 2.

## 3.0 POST-DEVELOPMENT CONDITIONS

### 3.1 **Design Strategy**

During the design phase of the site layout, consideration was given to conserving environmentally sensitive features and minimizing impact on the existing hydrology. To achieve this, extensive grading was avoided and the site was designed to match the existing terrain where feasible. Minimizing earthwork helps to maintain the existing drainage patterns to the maximum extent practicable under post-development conditions. On-site resource areas, such as the Bordering Vegetated Wetlands were excluded from the development envelope and will not be altered by the proposed project.

A stormwater management system has been designed to mitigate increased rates of runoff and to provide treatment for stormwater runoff associated with the proposed impervious surfaces on site. Stormwater BMPs were designed to treat a minimum of the first 1.0 inch of runoff generated by the majority of on-site impervious areas (the exceptions being portions of the proposed public access trail and adjacent fire lane). Proprietary structural treatment devices and a sediment forebay were designed to treat the runoff rate associated with the water quality volume for trafficked areas in accordance with the requirements of the DEP Stormwater Handbook. A majority of the proposed parking and associated driveways are routed through proprietary treatment devices prior to infiltrative BMPs.

The net increase in impervious area for the project is approximate to the combined rooftop area of the proposed residential buildings. Roof runoff is generally considered clean and does not require additional treatment for water quality. The total exposed paved area subject to traffic will be similar to that of the pre-development condition and a majority of this impervious will be treated to a higher standard than the existing paved areas.

Water quality sizing calculations are included in Attachment 5 of this report.

To mitigate increased stormwater runoff volumes associated with the proposed increase in impervious area, proposed stormwater BMPs include an infiltrative component. The infiltration system will overflow to proposed outfalls directed toward the existing wetlands, consistent with the existing hydrology of the site.

Additional subsurface storage volumes are proposed to compensate for proposed fill within the floodplain and to account for the increased runoff volume generated onsite for the 100-year storm event.

### 3.2 Hydrologic Analysis

The established design points used in the pre-development conditions analysis were used in the post-development analysis for direct comparison. The tributary areas and flow paths were modified to reflect post-development conditions. See Attachment 3 for the *Post- Development Conditions Hydrologic Areas Map*. Summaries of each area with respect to Curve Number and Time of Concentration calculations can be found in the model results in Attachment 3.

### 3.3 Stormwater Management Controls Sizing

#### ***Subsurface Infiltration Chambers***

The proposed stormwater infiltration systems consist of StormTrap vault-chambers (Subsurface #1 & #2) and Stormtech arch-chambers (Subsurface #3), with stone base. The systems have been designed with outlet controls (including emergency overflow weirs) within downgradient manholes to mitigate peak rates of runoff.

The infiltration system was sized using the Simple Dynamic Method, as described in Chapter 3 of the Massachusetts Stormwater Handbook, using a Rawl's exfiltration rate of 0.27 inches per hour. The system has been designed to meet the required recharge volume (associated with the net increase in impervious area) and will fully dewater within 72 hours.

Separate subsurface floodplain compensation volumes consisting of StormTrap vault-chamber systems are also proposed (though have not been modeled for mitigation of peak rates of runoff).

#### ***Water Quality Structures***

Five (5) water quality structures are proposed as part of the residential development. The water quality structures will treat the majority of pavement on the proposed residential lot except for a small portion of the ponding lot on the north side of the parcel which will drain to a sediment forebay.

#### ***Sediment Forebays***

A reconstructed sediment forebay is proposed to the north of the wetland pond to provide treatment for a small pavement area prior to discharge to the pond. The sediment forebays provide water quality treatment and reduces the velocity of stormwater runoff prior to discharge.

### 3.4 Hydraulic Calculations

To be provided at a later date.

### **3.5 Compliance with DEP Stormwater Management Standards**

The proposed stormwater management system was designed in compliance with the ten (10) DEP Stormwater Management Standards. The following summary provides key information related to the proposed stormwater management system, its design elements, and mitigation measures for potential impacts.

**STANDARD 1:**            **No new stormwater conveyance (e.g. outfalls) may discharge untreated stormwater directly to or cause erosion in wetlands or waters of the Commonwealth.**

There will be no direct discharge of untreated stormwater to nearby wetlands or waters of the Commonwealth. Runoff from all impervious areas of the site will be conveyed to stormwater management controls for infiltration, water quality treatment, and runoff rate attenuation prior to discharge to adjacent wetlands.

---

**STANDARD 2:**            **Stormwater management systems shall be designed so that post-development peak discharge rates do not exceed pre-development peak discharge rates.**

The stormwater management design will control post-development peak discharge rates for the 2, 10, 25, and 100-year, 24-hour storms so as to maintain pre-development peak discharge rates at the ultimate design points. Refer to Section 1.0 Introduction for a summary of the peak runoff rates.

---

**STANDARD 3:**            **Loss of annual recharge to groundwater shall be eliminated or minimized through the use of environmentally sensitive site design, low impact development techniques, stormwater management practices and good operation and maintenance. At a minimum, the annual recharge from the post-development site shall approximate the annual recharge from pre-development conditions based on soil types. This Standard is met when the stormwater management system is designed to infiltrate the required recharge volume as determined in accordance with the Massachusetts Stormwater Handbook.**

The stormwater management system includes three separate stormwater infiltration systems that will effectively recharge groundwater on-site. Infiltration BMPs were sized using the simple dynamic method based on the required recharge volume for the net increase in impervious area associated with the post-development site. As a result, annual recharge from the post-development site will approximate the annual recharge from the site under pre-development conditions. See Attachment 5 for stormwater BMP design worksheets and Groundwater Recharge Calculation.

**STANDARD 4:**            **Stormwater management systems shall be designed to remove 80% of the average annual post-construction load of Total Suspended Solids (TSS).**

The proposed development will meet the Standard 4 requirement to the maximum extent practicable using several on-site treatment trains that achieve 80% TSS removal (minimum) for a majority of the site, which is a significant improvement over the existing impervious areas. While portions of the public access trail and adjacent fire lane are not routed to a treatment BMP, a majority of the parking area and associated driveways are routed to water quality units before subsurface infiltration systems. The net increase in impervious area associated with the project is approximate to combined roof area of the proposed residential buildings, which does not require treatment for TSS.

Structural BMPs designed for water quality treatment include proprietary water quality treatment units and the reconstruction of a sediment forebay.

Proposed stormwater management BMPs will be operated and maintained to ensure continued water quality treatment of runoff. The Site Owner’s Manual will comply with the Long-Term Pollution Prevention Plan (Standard 4) and the Long-Term Operation and Maintenance Plan (Standard 9) requirements of the 2008 Massachusetts Department of Environmental Protection (MassDEP) Stormwater Management Standards. The Manual will outline source control and pollution prevention measures and maintenance requirements of stormwater best management practices (BMPs) associated with the proposed development.

---

**STANDARD 5:**            **For land uses with higher potential pollutant loads (LUHPPLs), source control and pollution prevention shall be implemented in accordance with the Massachusetts Stormwater Handbook to eliminate or reduce the discharge of stormwater runoff from such land uses to the maximum extent practicable.**

The proposed project is not associated with stormwater discharges from land uses with higher potential pollutant loads.

---

**STANDARD 6:**            **Stormwater discharges to critical areas must utilize certain stormwater management BMPs approved for critical areas. Critical areas are Outstanding Resource Waters, shellfish beds, swimming beaches, coldwater fisheries and recharge areas for public water supplies.**

There are no stormwater discharges to critical areas associated with this project.

---

**STANDARD 7:**            **Redevelopment of previously developed sites must meet the Stormwater Management Standards to the maximum extent practicable. However, if it is not practicable to meet all the Standards, new (retrofitted or expanded) stormwater management systems must be designed to improve existing conditions.**

The proposed project is new development, and therefore this standard does not apply.

---

**STANDARD 8:**            **A plan to control construction-related impacts during erosion, sedimentation and other pollutant sources during construction and land disturbance activities (construction period erosion, sedimentation, and pollution prevention plan) shall be developed and implemented.**

A Stormwater Pollution Prevention Plan (SWPPP) will be developed prior to construction to comply with Section 3 of the NPDES Construction General Permit for Stormwater Discharges; therefore the requirements of Standard 8 are fulfilled.

---

**STANDARD 9:**            **A Long-Term Operation and Maintenance (O&M) Plan shall be developed and implemented to ensure that stormwater management systems function as designed.**

The Site Owner’s Manual complies with the Long-Term Pollution Prevention Plan (Standard 4) and the Long-Term Operation and Maintenance Plan (Standard 9) requirements of the 2008 Massachusetts Department of Environmental Protection (MassDEP) Stormwater Management Standards. The Manual outlines source control and pollution prevention measures and maintenance requirements of the stormwater best management practices (BMPs) associated with the proposed development.

---

**STANDARD 10:**            **All illicit discharges to the stormwater management system are prohibited.**

There will be no illicit discharges to the proposed stormwater management system associated with the proposed project. An Illicit Discharge Compliance Statement is provided on the following page.

### 3.6 Illicit Discharge Compliance Statement

An illicit discharge is any discharge to a stormwater management system that is not comprised entirely of stormwater, discharges from fire-fighting activities, and certain non-designated non-stormwater discharges.

To the best of my knowledge, no detectable illicit discharge exists on site. The site plans included with this report detail the storm sewers that convey stormwater on the site and demonstrate that these systems do not include the entry of an illicit discharge. A Site Owner's Manual is also included, which contains the Long Term Pollution Plan that outlines measures to prevent future illicit discharges. As the Site Owner, I will ultimately be responsible for implementing the Long Term Pollution Prevention Plan.

Signature: \_\_\_\_\_  
Owner's Name



# Checklist for Stormwater Report

## A. Introduction

**Important:** When filling out forms on the computer, use only the tab key to move your cursor - do not use the return key.



A Stormwater Report must be submitted with the Notice of Intent permit application to document compliance with the Stormwater Management Standards. The following checklist is NOT a substitute for the Stormwater Report (which should provide more substantive and detailed information) but is offered here as a tool to help the applicant organize their Stormwater Management documentation for their Report and for the reviewer to assess this information in a consistent format. As noted in the Checklist, the Stormwater Report must contain the engineering computations and supporting information set forth in Volume 3 of the [Massachusetts Stormwater Handbook](#). The Stormwater Report must be prepared and certified by a Registered Professional Engineer (RPE) licensed in the Commonwealth.

The Stormwater Report must include:

- The Stormwater Checklist completed and stamped by a Registered Professional Engineer (see page 2) that certifies that the Stormwater Report contains all required submittals.<sup>1</sup> This Checklist is to be used as the cover for the completed Stormwater Report.
- Applicant/Project Name
- Project Address
- Name of Firm and Registered Professional Engineer that prepared the Report
- Long-Term Pollution Prevention Plan required by Standards 4-6
- Construction Period Pollution Prevention and Erosion and Sedimentation Control Plan required by Standard 8<sup>2</sup>
- Operation and Maintenance Plan required by Standard 9

In addition to all plans and supporting information, the Stormwater Report must include a brief narrative describing stormwater management practices, including environmentally sensitive site design and LID techniques, along with a diagram depicting runoff through the proposed BMP treatment train. Plans are required to show existing and proposed conditions, identify all wetland resource areas, NRCS soil types, critical areas, Land Uses with Higher Potential Pollutant Loads (LUHPPL), and any areas on the site where infiltration rate is greater than 2.4 inches per hour. The Plans shall identify the drainage areas for both existing and proposed conditions at a scale that enables verification of supporting calculations.

As noted in the Checklist, the Stormwater Management Report shall document compliance with each of the Stormwater Management Standards as provided in the Massachusetts Stormwater Handbook. The soils evaluation and calculations shall be done using the methodologies set forth in Volume 3 of the Massachusetts Stormwater Handbook.

To ensure that the Stormwater Report is complete, applicants are required to fill in the Stormwater Report Checklist by checking the box to indicate that the specified information has been included in the Stormwater Report. If any of the information specified in the checklist has not been submitted, the applicant must provide an explanation. The completed Stormwater Report Checklist and Certification must be submitted with the Stormwater Report.

<sup>1</sup> The Stormwater Report may also include the Illicit Discharge Compliance Statement required by Standard 10. If not included in the Stormwater Report, the Illicit Discharge Compliance Statement must be submitted prior to the discharge of stormwater runoff to the post-construction best management practices.

<sup>2</sup> For some complex projects, it may not be possible to include the Construction Period Erosion and Sedimentation Control Plan in the Stormwater Report. In that event, the issuing authority has the discretion to issue an Order of Conditions that approves the project and includes a condition requiring the proponent to submit the Construction Period Erosion and Sedimentation Control Plan before commencing any land disturbance activity on the site.



# Checklist for Stormwater Report

## B. Stormwater Checklist and Certification

The following checklist is intended to serve as a guide for applicants as to the elements that ordinarily need to be addressed in a complete Stormwater Report. The checklist is also intended to provide conservation commissions and other reviewing authorities with a summary of the components necessary for a comprehensive Stormwater Report that addresses the ten Stormwater Standards.

*Note:* Because stormwater requirements vary from project to project, it is possible that a complete Stormwater Report may not include information on some of the subjects specified in the Checklist. If it is determined that a specific item does not apply to the project under review, please note that the item is not applicable (N.A.) and provide the reasons for that determination.

A complete checklist must include the Certification set forth below signed by the Registered Professional Engineer who prepared the Stormwater Report.

### Registered Professional Engineer's Certification

I have reviewed the Stormwater Report, including the soil evaluation, computations, Long-term Pollution Prevention Plan, the Construction Period Erosion and Sedimentation Control Plan (if included), the Long-term Post-Construction Operation and Maintenance Plan, the Illicit Discharge Compliance Statement (if included) and the plans showing the stormwater management system, and have determined that they have been prepared in accordance with the requirements of the Stormwater Management Standards as further elaborated by the Massachusetts Stormwater Handbook. I have also determined that the information presented in the Stormwater Checklist is accurate and that the information presented in the Stormwater Report accurately reflects conditions at the site as of the date of this permit application.

Registered Professional Engineer Block and Signature

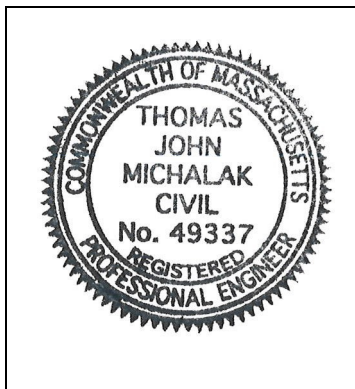

*Thomas J. Michalak* 9/19/2023  
Signature and Date

## Checklist

**Project Type:** Is the application for new development, redevelopment, or a mix of new and redevelopment?

- New development
- Redevelopment
- Mix of New Development and Redevelopment



# Checklist for Stormwater Report

---

## Checklist (continued)

**LID Measures:** Stormwater Standards require LID measures to be considered. Document what environmentally sensitive design and LID Techniques were considered during the planning and design of the project:

- No disturbance to any Wetland Resource Areas
- Site Design Practices (e.g. clustered development, reduced frontage setbacks)
- Reduced Impervious Area (Redevelopment Only)
- Minimizing disturbance to existing trees and shrubs
- LID Site Design Credit Requested:
  - Credit 1
  - Credit 2
  - Credit 3
- Use of “country drainage” versus curb and gutter conveyance and pipe
- Bioretention Cells (includes Rain Gardens)
- Constructed Stormwater Wetlands (includes Gravel Wetlands designs)
- Treebox Filter
- Water Quality Swale
- Grass Channel
- Green Roof
- Other (describe): \_\_\_\_\_

### Standard 1: No New Untreated Discharges

- No new untreated discharges
- Outlets have been designed so there is no erosion or scour to wetlands and waters of the Commonwealth
- Supporting calculations specified in Volume 3 of the Massachusetts Stormwater Handbook included.



# Checklist for Stormwater Report

---

## Checklist (continued)

### Standard 2: Peak Rate Attenuation

- Standard 2 waiver requested because the project is located in land subject to coastal storm flowage and stormwater discharge is to a wetland subject to coastal flooding.
- Evaluation provided to determine whether off-site flooding increases during the 100-year 24-hour storm.
- Calculations provided to show that post-development peak discharge rates do not exceed pre-development rates for the 2-year and 10-year 24-hour storms. If evaluation shows that off-site flooding increases during the 100-year 24-hour storm, calculations are also provided to show that post-development peak discharge rates do not exceed pre-development rates for the 100-year 24-hour storm.

### Standard 3: Recharge

- Soil Analysis provided.
- Required Recharge Volume calculation provided.
- Required Recharge volume reduced through use of the LID site Design Credits.
- Sizing the infiltration, BMPs is based on the following method: Check the method used.
  - Static
  - Simple Dynamic
  - Dynamic Field<sup>1</sup>
- Runoff from all impervious areas at the site discharging to the infiltration BMP.
- Runoff from all impervious areas at the site is *not* discharging to the infiltration BMP and calculations are provided showing that the drainage area contributing runoff to the infiltration BMPs is sufficient to generate the required recharge volume.
- Recharge BMPs have been sized to infiltrate the Required Recharge Volume.
- Recharge BMPs have been sized to infiltrate the Required Recharge Volume *only* to the maximum extent practicable for the following reason:
  - Site is comprised solely of C and D soils and/or bedrock at the land surface
  - M.G.L. c. 21E sites pursuant to 310 CMR 40.0000
  - Solid Waste Landfill pursuant to 310 CMR 19.000
  - Project is otherwise subject to Stormwater Management Standards only to the maximum extent practicable.
- Calculations showing that the infiltration BMPs will drain in 72 hours are provided.
- Property includes a M.G.L. c. 21E site or a solid waste landfill and a mounding analysis is included.

---

<sup>1</sup> 80% TSS removal is required prior to discharge to infiltration BMP if Dynamic Field method is used.



# Checklist for Stormwater Report

---

## Checklist (continued)

### Standard 3: Recharge (continued)

- The infiltration BMP is used to attenuate peak flows during storms greater than or equal to the 10-year 24-hour storm and separation to seasonal high groundwater is less than 4 feet and a mounding analysis is provided.
- Documentation is provided showing that infiltration BMPs do not adversely impact nearby wetland resource areas.

### Standard 4: Water Quality

The Long-Term Pollution Prevention Plan typically includes the following:

- Good housekeeping practices;
  - Provisions for storing materials and waste products inside or under cover;
  - Vehicle washing controls;
  - Requirements for routine inspections and maintenance of stormwater BMPs;
  - Spill prevention and response plans;
  - Provisions for maintenance of lawns, gardens, and other landscaped areas;
  - Requirements for storage and use of fertilizers, herbicides, and pesticides;
  - Pet waste management provisions;
  - Provisions for operation and management of septic systems;
  - Provisions for solid waste management;
  - Snow disposal and plowing plans relative to Wetland Resource Areas;
  - Winter Road Salt and/or Sand Use and Storage restrictions;
  - Street sweeping schedules;
  - Provisions for prevention of illicit discharges to the stormwater management system;
  - Documentation that Stormwater BMPs are designed to provide for shutdown and containment in the event of a spill or discharges to or near critical areas or from LUHPPL;
  - Training for staff or personnel involved with implementing Long-Term Pollution Prevention Plan;
  - List of Emergency contacts for implementing Long-Term Pollution Prevention Plan.
- A Long-Term Pollution Prevention Plan is attached to Stormwater Report and is included as an attachment to the Wetlands Notice of Intent.
  - Treatment BMPs subject to the 44% TSS removal pretreatment requirement and the one inch rule for calculating the water quality volume are included, and discharge:
    - is within the Zone II or Interim Wellhead Protection Area
    - is near or to other critical areas
    - is within soils with a rapid infiltration rate (greater than 2.4 inches per hour)
    - involves runoff from land uses with higher potential pollutant loads.
  - The Required Water Quality Volume is reduced through use of the LID site Design Credits.
  - Calculations documenting that the treatment train meets the 80% TSS removal requirement and, if applicable, the 44% TSS removal pretreatment requirement, are provided.



# Checklist for Stormwater Report

---

## Checklist (continued)

### Standard 4: Water Quality (continued)

- The BMP is sized (and calculations provided) based on:
  - The ½" or 1" Water Quality Volume or
  - The equivalent flow rate associated with the Water Quality Volume and documentation is provided showing that the BMP treats the required water quality volume.
- The applicant proposes to use proprietary BMPs, and documentation supporting use of proprietary BMP and proposed TSS removal rate is provided. This documentation may be in the form of the propriety BMP checklist found in Volume 2, Chapter 4 of the Massachusetts Stormwater Handbook and submitting copies of the TARP Report, STEP Report, and/or other third party studies verifying performance of the proprietary BMPs.
- A TMDL exists that indicates a need to reduce pollutants other than TSS and documentation showing that the BMPs selected are consistent with the TMDL is provided.

### Standard 5: Land Uses With Higher Potential Pollutant Loads (LUHPPLs)

- The NPDES Multi-Sector General Permit covers the land use and the Stormwater Pollution Prevention Plan (SWPPP) has been included with the Stormwater Report.
- The NPDES Multi-Sector General Permit covers the land use and the SWPPP will be submitted **prior to** the discharge of stormwater to the post-construction stormwater BMPs.
- The NPDES Multi-Sector General Permit does **not** cover the land use.
- LUHPPLs are located at the site and industry specific source control and pollution prevention measures have been proposed to reduce or eliminate the exposure of LUHPPLs to rain, snow, snow melt and runoff, and been included in the long term Pollution Prevention Plan.
- All exposure has been eliminated.
- All exposure has **not** been eliminated and all BMPs selected are on MassDEP LUHPPL list.
- The LUHPPL has the potential to generate runoff with moderate to higher concentrations of oil and grease (e.g. all parking lots with >1000 vehicle trips per day) and the treatment train includes an oil grit separator, a filtering bioretention area, a sand filter or equivalent.

### Standard 6: Critical Areas

- The discharge is near or to a critical area and the treatment train includes only BMPs that MassDEP has approved for stormwater discharges to or near that particular class of critical area.
- Critical areas and BMPs are identified in the Stormwater Report.



# Checklist for Stormwater Report

---

## Checklist (continued)

### Standard 7: Redevelopments and Other Projects Subject to the Standards only to the maximum extent practicable

- The project is subject to the Stormwater Management Standards only to the maximum Extent Practicable as a:
  - Limited Project
  - Small Residential Projects: 5-9 single family houses or 5-9 units in a multi-family development provided there is no discharge that may potentially affect a critical area.
  - Small Residential Projects: 2-4 single family houses or 2-4 units in a multi-family development with a discharge to a critical area
  - Marina and/or boatyard provided the hull painting, service and maintenance areas are protected from exposure to rain, snow, snow melt and runoff
  - Bike Path and/or Foot Path
  - Redevelopment Project
- Redevelopment portion of mix of new and redevelopment.
- Certain standards are not fully met (Standard No. 1, 8, 9, and 10 must always be fully met) and an explanation of why these standards are not met is contained in the Stormwater Report.
- The project involves redevelopment and a description of all measures that have been taken to improve existing conditions is provided in the Stormwater Report. The redevelopment checklist found in Volume 2 Chapter 3 of the Massachusetts Stormwater Handbook may be used to document that the proposed stormwater management system (a) complies with Standards 2, 3 and the pretreatment and structural BMP requirements of Standards 4-6 to the maximum extent practicable and (b) improves existing conditions.

### Standard 8: Construction Period Pollution Prevention and Erosion and Sedimentation Control

A Construction Period Pollution Prevention and Erosion and Sedimentation Control Plan must include the following information:

- Narrative;
  - Construction Period Operation and Maintenance Plan;
  - Names of Persons or Entity Responsible for Plan Compliance;
  - Construction Period Pollution Prevention Measures;
  - Erosion and Sedimentation Control Plan Drawings;
  - Detail drawings and specifications for erosion control BMPs, including sizing calculations;
  - Vegetation Planning;
  - Site Development Plan;
  - Construction Sequencing Plan;
  - Sequencing of Erosion and Sedimentation Controls;
  - Operation and Maintenance of Erosion and Sedimentation Controls;
  - Inspection Schedule;
  - Maintenance Schedule;
  - Inspection and Maintenance Log Form.
- A Construction Period Pollution Prevention and Erosion and Sedimentation Control Plan containing the information set forth above has been included in the Stormwater Report.



# Checklist for Stormwater Report

---

## Checklist (continued)

### Standard 8: Construction Period Pollution Prevention and Erosion and Sedimentation Control (continued)

- The project is highly complex and information is included in the Stormwater Report that explains why it is not possible to submit the Construction Period Pollution Prevention and Erosion and Sedimentation Control Plan with the application. A Construction Period Pollution Prevention and Erosion and Sedimentation Control has **not** been included in the Stormwater Report but will be submitted **before** land disturbance begins.
- The project is **not** covered by a NPDES Construction General Permit.
- The project is covered by a NPDES Construction General Permit and a copy of the SWPPP is in the Stormwater Report.
- The project is covered by a NPDES Construction General Permit but no SWPPP been submitted. The SWPPP will be submitted BEFORE land disturbance begins.

### Standard 9: Operation and Maintenance Plan

- The Post Construction Operation and Maintenance Plan is included in the Stormwater Report and includes the following information:
  - Name of the stormwater management system owners;
  - Party responsible for operation and maintenance;
  - Schedule for implementation of routine and non-routine maintenance tasks;
  - Plan showing the location of all stormwater BMPs maintenance access areas;
  - Description and delineation of public safety features;
  - Estimated operation and maintenance budget; and
  - Operation and Maintenance Log Form.
- The responsible party is **not** the owner of the parcel where the BMP is located and the Stormwater Report includes the following submissions:
  - A copy of the legal instrument (deed, homeowner's association, utility trust or other legal entity) that establishes the terms of and legal responsibility for the operation and maintenance of the project site stormwater BMPs;
  - A plan and easement deed that allows site access for the legal entity to operate and maintain BMP functions.

### Standard 10: Prohibition of Illicit Discharges

- The Long-Term Pollution Prevention Plan includes measures to prevent illicit discharges;
- An Illicit Discharge Compliance Statement is attached;
- NO Illicit Discharge Compliance Statement is attached but will be submitted **prior to** the discharge of any stormwater to post-construction BMPs.

**Attachment 1**  
**Soil Data**

---

Hydrologic Soil Group—Middlesex County, Massachusetts  
(2063.27 )

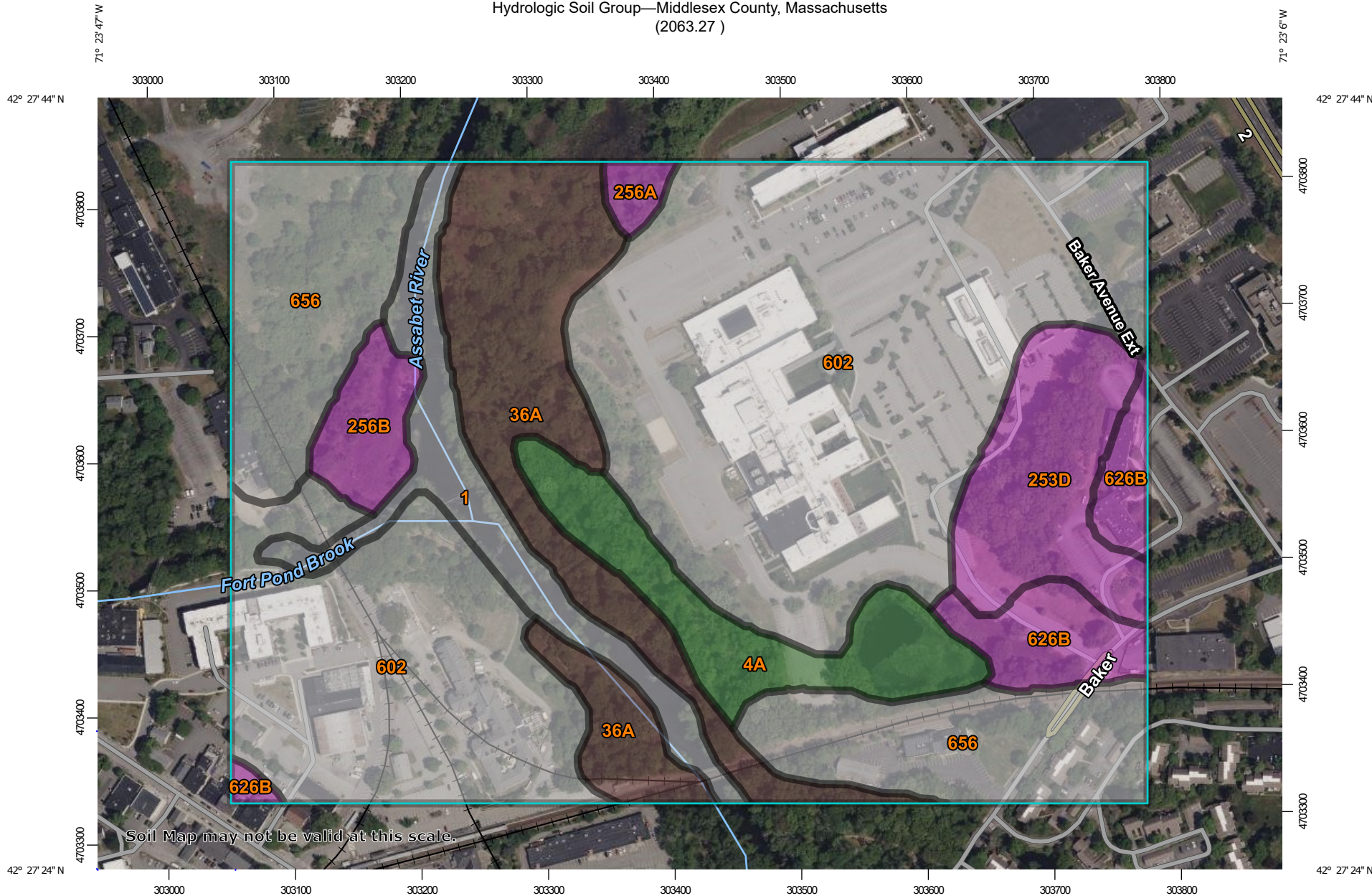

Soil Map may not be valid at this scale.

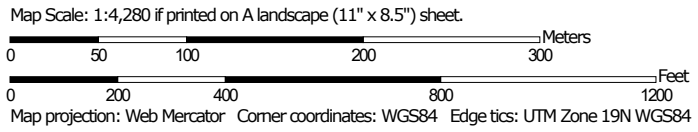

## MAP LEGEND

### Area of Interest (AOI)









 Area of Interest (AOI)

### Soils

#### Soil Rating Polygons





 A  
 A/D  
 B  
 B/D  
 C  
 C/D  
 D  
 Not rated or not available

#### Soil Rating Lines

 A  
 A/D  
 B  
 B/D  
 C  
 C/D  
 D  
 Not rated or not available

#### Soil Rating Points





 A  
 A/D  
 B  
 B/D

 C  
 C/D  
 D  
 Not rated or not available

### Water Features

 Streams and Canals

### Transportation

 Rails  
 Interstate Highways  
 US Routes  
 Major Roads  
 Local Roads

### Background

 Aerial Photography

## MAP INFORMATION

The soil surveys that comprise your AOI were mapped at 1:25,000.

Warning: Soil Map may not be valid at this scale.

Enlargement of maps beyond the scale of mapping can cause misunderstanding of the detail of mapping and accuracy of soil line placement. The maps do not show the small areas of contrasting soils that could have been shown at a more detailed scale.

Please rely on the bar scale on each map sheet for map measurements.

Source of Map: Natural Resources Conservation Service  
 Web Soil Survey URL:  
 Coordinate System: Web Mercator (EPSG:3857)

Maps from the Web Soil Survey are based on the Web Mercator projection, which preserves direction and shape but distorts distance and area. A projection that preserves area, such as the Albers equal-area conic projection, should be used if more accurate calculations of distance or area are required.

This product is generated from the USDA-NRCS certified data as of the version date(s) listed below.

Soil Survey Area: Middlesex County, Massachusetts  
 Survey Area Data: Version 22, Sep 9, 2022

Soil map units are labeled (as space allows) for map scales 1:50,000 or larger.

Date(s) aerial images were photographed: May 22, 2022—Jun 5, 2022

The orthophoto or other base map on which the soil lines were compiled and digitized probably differs from the background imagery displayed on these maps. As a result, some minor shifting of map unit boundaries may be evident.

## Hydrologic Soil Group

| Map unit symbol                    | Map unit name  | Rating | Acres in AOI | Percent of AOI |
|------------------------------------|--|--------|--------------|----------------|
| 1                                  | Water  |        | 5.2          | 5.8%           |
| 4A                                 | Rippowam fine sandy loam, 0 to 3 percent slopes, frequently flooded                | A/D    | 5.3          | 5.9%           |
| 36A                                | Saco mucky silt loam, frequently ponded, 0 to 1 percent slopes, frequently flooded | B/D    | 11.4         | 12.5%          |
| 253D                               | Hinckley loamy sand, 15 to 25 percent slopes                                       | A      | 5.9          | 6.4%           |
| 256A                               | Deerfield loamy fine sand, 0 to 3 percent slopes                                   | A      | 0.6          | 0.7%           |
| 256B                               | Deerfield loamy fine sand, 3 to 8 percent slopes                                   | A      | 2.0          | 2.2%           |
| 602                                | Urban land   |        | 43.1         | 47.5%          |
| 626B                               | Merrimac-Urban land complex, 0 to 8 percent slopes                                 | A      | 3.7          | 4.1%           |
| 656                                | Udorthents-Urban land complex  |        | 13.5         | 14.9%          |
| <b>Totals for Area of Interest</b> |  |        | <b>90.7</b>  | <b>100.0%</b>  |

## Description

Hydrologic soil groups are based on estimates of runoff potential. Soils are assigned to one of four groups according to the rate of water infiltration when the soils are not protected by vegetation, are thoroughly wet, and receive precipitation from long-duration storms.

The soils in the United States are assigned to four groups (A, B, C, and D) and three dual classes (A/D, B/D, and C/D). The groups are defined as follows:

Group A. Soils having a high infiltration rate (low runoff potential) when thoroughly wet. These consist mainly of deep, well drained to excessively drained sands or gravelly sands. These soils have a high rate of water transmission.

Group B. Soils having a moderate infiltration rate when thoroughly wet. These consist chiefly of moderately deep or deep, moderately well drained or well drained soils that have moderately fine texture to moderately coarse texture. These soils have a moderate rate of water transmission.

Group C. Soils having a slow infiltration rate when thoroughly wet. These consist chiefly of soils having a layer that impedes the downward movement of water or soils of moderately fine texture or fine texture. These soils have a slow rate of water transmission.

Group D. Soils having a very slow infiltration rate (high runoff potential) when thoroughly wet. These consist chiefly of clays that have a high shrink-swell potential, soils that have a high water table, soils that have a claypan or clay layer at or near the surface, and soils that are shallow over nearly impervious material. These soils have a very slow rate of water transmission.

If a soil is assigned to a dual hydrologic group (A/D, B/D, or C/D), the first letter is for drained areas and the second is for undrained areas. Only the soils that in their natural condition are in group D are assigned to dual classes.

## Rating Options

*Aggregation Method:* Dominant Condition

*Component Percent Cutoff:* None Specified

*Tie-break Rule:* Higher

## Map Unit Description (Brief, Generated)

The map units delineated on the detailed soil maps in a soil survey represent the soils or miscellaneous areas in the survey area. The map unit descriptions in this report, along with the maps, provide information on the composition of map units and properties of their components.

A map unit delineation on a soil map represents an area dominated by one or more major kinds of soil or miscellaneous areas. A map unit is identified and named according to the taxonomic classification of the dominant soils. Within a taxonomic class there are precisely defined limits for the properties of the soils. On the landscape, however, the soils are natural phenomena, and they have the characteristic variability of all natural phenomena. Thus, the range of some observed properties may extend beyond the limits defined for a taxonomic class. Areas of soils of a single taxonomic class rarely, if ever, can be mapped without including areas of other taxonomic classes. Consequently, every map unit is made up of the soils or miscellaneous areas for which it is named and some minor components that belong to taxonomic classes other than those of the major soils.

The Map Unit Description (Brief, Generated) report displays a generated description of the major soils that occur in a map unit. Descriptions of non-soil (miscellaneous areas) and minor map unit components are not included. This description is generated from the underlying soil attribute data.

Additional information about the map units described in this report is available in other Soil Data Mart reports, which give properties of the soils and the limitations, capabilities, and potentials for many uses. Also, the narratives that accompany the Soil Data Mart reports define some of the properties included in the map unit descriptions.

## Report—Map Unit Description (Brief, Generated)

### Middlesex County, Massachusetts

**Map Unit:** 1—Water

**Component:** Water (100%)

Generated brief soil descriptions are created for major soil components. The Water is a miscellaneous area.

**Map Unit:** 4A—Rippowam fine sandy loam, 0 to 3 percent slopes, frequently flooded

**Component:** Rippowam (80%)

The Rippowam component makes up 80 percent of the map unit. Slopes are 0 to 3 percent. This component is on alluvial flats on alluvial plains. The parent material consists of loamy alluvium over sandy and gravelly alluvium derived from granite and gneiss. Depth to a root restrictive layer is greater than 60 inches. The natural drainage class is poorly drained. Water movement in the most restrictive layer is moderately high. Available water to a depth of 60 inches (or restricted depth) is moderate. Shrink-swell potential is low. This soil is frequently flooded. It is not ponded. A seasonal zone of water saturation is at 9 inches during January, February, March, April, May, June, September, October, November, December. Organic matter content in the surface horizon is about 6 percent. This component is in the F144AY014CT Wet Sandy Low Floodplain ecological site. Nonirrigated land capability classification is 4w. This soil meets hydric criteria.

**Component: Saco (10%)**

Generated brief soil descriptions are created for major soil components. The Saco soil is a minor component.

**Component: Pootatuck (5%)**

Generated brief soil descriptions are created for major soil components. The Pootatuck soil is a minor component.

**Component: Limerick (5%)**

Generated brief soil descriptions are created for major soil components. The Limerick soil is a minor component.

**Map Unit: 36A**—Saco mucky silt loam, frequently ponded, 0 to 1 percent slopes, frequently flooded

**Component: Saco (80%)**

The Saco component makes up 80 percent of the map unit. Slopes are 0 to 1 percent. This component is on alluvial flats on alluvial plains, terraces on alluvial plains. The parent material consists of silty alluvium. Depth to a root restrictive layer is greater than 60 inches. The natural drainage class is very poorly drained. Water movement in the most restrictive layer is moderately high. Available water to a depth of 60 inches (or restricted depth) is high. Shrink-swell potential is low. This soil is frequently flooded. It is frequently ponded. A seasonal zone of water saturation is at 0 inches during January, February, March, April, May, June, October, November, December. Organic matter content in the surface horizon is about 15 percent. This component is in the F144AY016MA Very Wet Low Floodplain ecological site. Nonirrigated land capability classification is 6w. This soil meets hydric criteria.

**Component: Freetown (8%)**

Generated brief soil descriptions are created for major soil components. The Freetown soil is a minor component.

**Component:** Swansea (8%)

Generated brief soil descriptions are created for major soil components. The Swansea soil is a minor component.

**Component:** Limerick (4%)

Generated brief soil descriptions are created for major soil components. The Limerick soil is a minor component.

**Map Unit:** 253D—Hinckley loamy sand, 15 to 25 percent slopes**Component:** Hinckley (85%)

The Hinckley component makes up 85 percent of the map unit. Slopes are 15 to 25 percent. This component is on kames on valleys. The parent material consists of sandy and gravelly glaciofluvial deposits derived from gneiss and/or granite and/or schist. Depth to a root restrictive layer is greater than 60 inches. The natural drainage class is excessively drained. Water movement in the most restrictive layer is high. Available water to a depth of 60 inches (or restricted depth) is very low. Shrink-swell potential is low. This soil is not flooded. It is not ponded. There is no zone of water saturation within a depth of 72 inches. Organic matter content in the surface horizon is about 95 percent. Below this thin organic horizon the organic matter content is about 6 percent. This component is in the F144AY022MA Dry Outwash ecological site. Nonirrigated land capability classification is 6e. This soil does not meet hydric criteria.

**Component:** Merrimac (8%)

Generated brief soil descriptions are created for major soil components. The Merrimac soil is a minor component.

**Component:** Windsor (5%)

Generated brief soil descriptions are created for major soil components. The Windsor soil is a minor component.

**Component:** Sudbury (2%)

Generated brief soil descriptions are created for major soil components. The Sudbury soil is a minor component.

**Map Unit:** 256A—Deerfield loamy fine sand, 0 to 3 percent slopes**Component:** Deerfield (85%)

The Deerfield component makes up 85 percent of the map unit. Slopes are 0 to 3 percent. This component is on outwash plains on lowlands. The parent material consists of sandy outwash derived from granite, gneiss, and/or quartzite. Depth to a root restrictive layer is greater than 60 inches. The natural drainage class is moderately well drained. Water movement in the most restrictive layer is high. Available water to a depth of 60 inches (or restricted depth) is moderate. Shrink-swell potential is low. This soil is not flooded. It is not ponded. A seasonal zone of water saturation is at 25 inches during January, February, March, April, May, June, November, December. Organic matter content in the surface horizon is about 3 percent. This component is in the F144AY027MA Moist Sandy Outwash ecological site. Nonirrigated land capability classification is 2w. This soil does not meet hydric criteria.

**Component: Windsor (7%)**

Generated brief soil descriptions are created for major soil components. The Windsor soil is a minor component.

**Component: Wareham (5%)**

Generated brief soil descriptions are created for major soil components. The Wareham soil is a minor component.

**Component: Sudbury (2%)**

Generated brief soil descriptions are created for major soil components. The Sudbury soil is a minor component.

**Component: Ninigret (1%)**

Generated brief soil descriptions are created for major soil components. The Ninigret soil is a minor component.

**Map Unit: 256B—Deerfield loamy fine sand, 3 to 8 percent slopes**

**Component: Deerfield (85%)**

The Deerfield component makes up 85 percent of the map unit. Slopes are 3 to 8 percent. This component is on outwash plains on lowlands. The parent material consists of sandy outwash derived from granite, gneiss, and/or quartzite. Depth to a root restrictive layer is greater than 60 inches. The natural drainage class is moderately well drained. Water movement in the most restrictive layer is high. Available water to a depth of 60 inches (or restricted depth) is moderate. Shrink-swell potential is low. This soil is not flooded. It is not ponded. A seasonal zone of water saturation is at 25 inches during January, February, March, April, May, June, November, December. Organic matter content in the surface horizon is about 3 percent. This component is in the F144AY027MA Moist Sandy Outwash ecological site. Nonirrigated land capability classification is 2w. This soil does not meet hydric criteria.

**Component: Windsor (7%)**

Generated brief soil descriptions are created for major soil components. The Windsor soil is a minor component.

**Component:** Wareham (5%)

Generated brief soil descriptions are created for major soil components. The Wareham soil is a minor component.

**Component:** Sudbury (2%)

Generated brief soil descriptions are created for major soil components. The Sudbury soil is a minor component.

**Component:** Ninigret (1%)

Generated brief soil descriptions are created for major soil components. The Ninigret soil is a minor component.

**Map Unit:** 602—Urban land

**Component:** Urban land (85%)

Generated brief soil descriptions are created for major soil components. The Urban land is a miscellaneous area.

**Component:** Udorthents, loamy (5%)

Generated brief soil descriptions are created for major soil components. The Udorthents, loamy soil is a minor component.

**Component:** Rock outcrop (5%)

Generated brief soil descriptions are created for major soil components. The Rock outcrop soil is a minor component.

**Component:** Udorthents, wet substratum (5%)

Generated brief soil descriptions are created for major soil components. The Udorthents, wet substratum soil is a minor component.

**Map Unit:** 626B—Merrimac-Urban land complex, 0 to 8 percent slopes

**Component:** Merrimac (45%)

The Merrimac component makes up 45 percent of the map unit. Slopes are 0 to 8 percent. This component is on outwash terraces on outwash plains. The parent material consists of loamy glaciofluvial deposits derived from granite, schist, and gneiss over sandy and gravelly glaciofluvial deposits derived from granite, schist, and gneiss. Depth to a root restrictive layer is greater than 60 inches. The natural drainage class is somewhat excessively drained. Water movement in the most restrictive layer is high. Available water to a depth of 60 inches (or restricted depth) is low. Shrink-swell potential is low. This soil is not flooded. It is not ponded. There is no zone of water saturation within a depth of 72 inches. Organic matter content in the surface horizon is about 4 percent. This component is in the F144AY022MA Dry Outwash ecological site. Nonirrigated land capability classification is 2e. This soil does not meet hydric criteria. There are no saline horizons within 30 inches of the soil surface.

**Component:** Urban land (40%)

Generated brief soil descriptions are created for major soil components. The Urban land is a miscellaneous area.

**Component:** Windsor (5%)

Generated brief soil descriptions are created for major soil components. The Windsor soil is a minor component.

**Component:** Sudbury (5%)

Generated brief soil descriptions are created for major soil components. The Sudbury soil is a minor component.

**Component:** Hinckley (5%)

Generated brief soil descriptions are created for major soil components. The Hinckley soil is a minor component.

**Map Unit:** 656—Udorthents-Urban land complex

**Component:** Udorthents (45%)

The Udorthents component makes up 45 percent of the map unit. Slopes are 0 to 15 percent. This component is on fills, leveled land, railroad beds, sanitary landfills. The parent material consists of loamy alluvium and/or sandy glaciofluvial deposits and/or loamy glaciolacustrine deposits and/or loamy marine deposits and/or loamy basal till and/or loamy lodgment till. Depth to a root restrictive layer is greater than 60 inches. Available water to a depth of 60 inches (or restricted depth) is very low. Shrink-swell potential is low. This soil is not flooded. It is not ponded. There is no zone of water saturation within a depth of 72 inches. This soil does not meet hydric criteria.

**Component:** Urban land (35%)

Generated brief soil descriptions are created for major soil components. The Urban land is a miscellaneous area.

**Component:** Canton (10%)

Generated brief soil descriptions are created for major soil components. The Canton soil is a minor component.

**Component:** Merrimac (5%)

Generated brief soil descriptions are created for major soil components. The Merrimac soil is a minor component.

**Component:** Paxton (5%)

Generated brief soil descriptions are created for major soil components. The Paxton soil is a minor component.

## Data Source Information

Soil Survey Area: Middlesex County, Massachusetts  
Survey Area Data: Version 22, Sep 9, 2022

## Map Unit Description

The map units delineated on the detailed soil maps in a soil survey represent the soils or miscellaneous areas in the survey area. The map unit descriptions in this report, along with the maps, can be used to determine the composition and properties of a unit.

A map unit delineation on a soil map represents an area dominated by one or more major kinds of soil or miscellaneous areas. A map unit is identified and named according to the taxonomic classification of the dominant soils. Within a taxonomic class there are precisely defined limits for the properties of the soils. On the landscape, however, the soils are natural phenomena, and they have the characteristic variability of all natural phenomena. Thus, the range of some observed properties may extend beyond the limits defined for a taxonomic class. Areas of soils of a single taxonomic class rarely, if ever, can be mapped without including areas of other taxonomic classes. Consequently, every map unit is made up of the soils or miscellaneous areas for which it is named, soils that are similar to the named components, and some minor components that differ in use and management from the major soils.

Most of the soils similar to the major components have properties similar to those of the dominant soil or soils in the map unit, and thus they do not affect use and management. These are called noncontrasting, or similar, components. They may or may not be mentioned in a particular map unit description. Some minor components, however, have properties and behavior characteristics divergent enough to affect use or to require different management. These are called contrasting, or dissimilar, components. They generally are in small areas and could not be mapped separately because of the scale used. Some small areas of strongly contrasting soils or miscellaneous areas are identified by a special symbol on the maps. If included in the database for a given area, the contrasting minor components are identified in the map unit descriptions along with some characteristics of each. A few areas of minor components may not have been observed, and consequently they are not mentioned in the descriptions, especially where the pattern was so complex that it was impractical to make enough observations to identify all the soils and miscellaneous areas on the landscape.

The presence of minor components in a map unit in no way diminishes the usefulness or accuracy of the data. The objective of mapping is not to delineate pure taxonomic classes but rather to separate the landscape into landforms or landform segments that have similar use and management requirements. The delineation of such segments on the map provides sufficient information for the development of resource plans. If intensive use of small areas is planned, however, onsite investigation is needed to define and locate the soils and miscellaneous areas.

An identifying symbol precedes the map unit name in the map unit descriptions. Each description includes general facts about the unit and gives important soil properties and qualities.

Soils that have profiles that are almost alike make up a *soil series*. All the soils of a series have major horizons that are similar in composition, thickness, and arrangement. Soils of a given series can differ in texture of the surface layer, slope, stoniness, salinity, degree of erosion, and other characteristics that affect their use. On the basis of such differences, a soil series is divided into *soil phases*. Most of the areas shown on the detailed soil maps are phases of soil series. The name of a soil phase commonly indicates a feature that affects use or management. For example, Alpha silt loam, 0 to 2 percent slopes, is a phase of the Alpha series.

Some map units are made up of two or more major soils or miscellaneous areas. These map units are complexes, associations, or undifferentiated groups.

A *complex* consists of two or more soils or miscellaneous areas in such an intricate pattern or in such small areas that they cannot be shown separately on the maps. The pattern and proportion of the soils or miscellaneous areas are somewhat similar in all areas. Alpha-Beta complex, 0 to 6 percent slopes, is an example.

An *association* is made up of two or more geographically associated soils or miscellaneous areas that are shown as one unit on the maps. Because of present or anticipated uses of the map units in the survey area, it was not considered practical or necessary to map the soils or miscellaneous areas separately. The pattern and relative proportion of the soils or miscellaneous areas are somewhat similar. Alpha-Beta association, 0 to 2 percent slopes, is an example.

An *undifferentiated group* is made up of two or more soils or miscellaneous areas that could be mapped individually but are mapped as one unit because similar interpretations can be made for use and management. The pattern and proportion of the soils or miscellaneous areas in a mapped area are not uniform. An area can be made up of only one of the major soils or miscellaneous areas, or it can be made up of all of them. Alpha and Beta soils, 0 to 2 percent slopes, is an example.

Some surveys include *miscellaneous areas*. Such areas have little or no soil material and support little or no vegetation. Rock outcrop is an example.

Additional information about the map units described in this report is available in other soil reports, which give properties of the soils and the limitations, capabilities, and potentials for many uses. Also, the narratives that accompany the soil reports define some of the properties included in the map unit descriptions.

## Report—Map Unit Description

### Middlesex County, Massachusetts

#### 1—Water

##### Map Unit Setting

*National map unit symbol:* 996p

*Frost-free period:* 110 to 200 days

*Farmland classification:* Not prime farmland

**Map Unit Composition**

*Water:* 100 percent

*Estimates are based on observations, descriptions, and transects of the mapunit.*

**Description of Water**

**Setting**

*Landform position (two-dimensional):* Toeslope

*Landform position (three-dimensional):* Dip

*Down-slope shape:* Linear

*Across-slope shape:* Linear

**4A—Rippowam fine sandy loam, 0 to 3 percent slopes, frequently flooded**

**Map Unit Setting**

*National map unit symbol:* 2zvd6

*Elevation:* 50 to 1,180 feet

*Mean annual precipitation:* 45 to 54 inches

*Mean annual air temperature:* 43 to 54 degrees F

*Frost-free period:* 145 to 240 days

*Farmland classification:* Not prime farmland

**Map Unit Composition**

*Rippowam and similar soils:* 80 percent

*Minor components:* 20 percent

*Estimates are based on observations, descriptions, and transects of the mapunit.*

**Description of Rippowam**

**Setting**

*Landform:* Alluvial flats

*Landform position (two-dimensional):* Toeslope

*Landform position (three-dimensional):* Dip

*Down-slope shape:* Linear

*Across-slope shape:* Concave

*Parent material:* Loamy alluvium over sandy and gravelly alluvium derived from granite and gneiss

**Typical profile**

*H1 - 0 to 7 inches:* fine sandy loam

*H2 - 7 to 18 inches:* fine sandy loam

*H3 - 18 to 40 inches:* sandy loam

*H4 - 40 to 65 inches:* stratified sand to fine sand

**Properties and qualities**

*Slope:* 0 to 3 percent

*Depth to restrictive feature:* More than 80 inches

*Drainage class:* Poorly drained

*Capacity of the most limiting layer to transmit water (Ksat):* Moderately high to high (0.60 to 6.00 in/hr)  
*Depth to water table:* About 6 to 18 inches  
*Frequency of flooding:* FrequentNone  
*Frequency of ponding:* None  
*Available water supply, 0 to 60 inches:* Moderate (about 6.9 inches)

#### **Interpretive groups**

*Land capability classification (irrigated):* None specified  
*Land capability classification (nonirrigated):* 4w  
*Hydrologic Soil Group:* A/D  
*Ecological site:* F144AY014CT - Wet Sandy Low Floodplain  
*Hydric soil rating:* Yes

#### **Minor Components**

##### **Saco**

*Percent of map unit:* 10 percent  
*Landform:* Terraces, alluvial flats  
*Landform position (two-dimensional):* Toeslope  
*Landform position (three-dimensional):* Tread, dip  
*Down-slope shape:* Linear  
*Across-slope shape:* Concave  
*Hydric soil rating:* Yes

##### **Pootatuck**

*Percent of map unit:* 5 percent  
*Landform:* Flood plains  
*Landform position (two-dimensional):* Toeslope  
*Landform position (three-dimensional):* Dip  
*Down-slope shape:* Linear  
*Across-slope shape:* Concave  
*Hydric soil rating:* No

##### **Limerick**

*Percent of map unit:* 5 percent  
*Landform:* Terraces, alluvial flats  
*Landform position (two-dimensional):* Toeslope  
*Landform position (three-dimensional):* Tread, dip  
*Down-slope shape:* Linear  
*Across-slope shape:* Concave  
*Hydric soil rating:* Yes

### **36A—Saco mucky silt loam, frequently ponded, 0 to 1 percent slopes, frequently flooded**

#### **Map Unit Setting**

*National map unit symbol:* 2zvf1  
*Elevation:* 30 to 500 feet  
*Mean annual precipitation:* 45 to 54 inches  
*Mean annual air temperature:* 43 to 54 degrees F  
*Frost-free period:* 145 to 240 days

*Farmland classification:* Not prime farmland

### **Map Unit Composition**

*Saco and similar soils:* 80 percent

*Minor components:* 20 percent

*Estimates are based on observations, descriptions, and transects of the mapunit.*

### **Description of Saco**

#### **Setting**

*Landform:* Terraces, alluvial flats

*Landform position (two-dimensional):* Toeslope

*Landform position (three-dimensional):* Tread, dip

*Down-slope shape:* Linear

*Across-slope shape:* Concave

*Parent material:* Silty alluvium

#### **Typical profile**

*H1 - 0 to 13 inches:* mucky silt loam

*H2 - 13 to 30 inches:* silt loam

*H3 - 30 to 45 inches:* silt loam

*H4 - 45 to 65 inches:* loamy sand

#### **Properties and qualities**

*Slope:* 0 to 1 percent

*Depth to restrictive feature:* More than 80 inches

*Drainage class:* Very poorly drained

*Capacity of the most limiting layer to transmit water*

*(Ksat):* Moderately high to high (0.60 to 2.00 in/hr)

*Depth to water table:* About 0 to 2 inches

*Frequency of flooding:* Frequent

*Frequency of ponding:* Frequent

*Available water supply, 0 to 60 inches:* High (about 11.5 inches)

#### **Interpretive groups**

*Land capability classification (irrigated):* None specified

*Land capability classification (nonirrigated):* 6w

*Hydrologic Soil Group:* B/D

*Ecological site:* F144AY016MA - Very Wet Low Floodplain

*Hydric soil rating:* Yes

### **Minor Components**

#### **Freetown**

*Percent of map unit:* 8 percent

*Landform:* Bogs, depressions

*Landform position (two-dimensional):* Toeslope

*Landform position (three-dimensional):* Dip

*Down-slope shape:* Concave

*Across-slope shape:* Concave

*Hydric soil rating:* Yes

### **Swansea**

*Percent of map unit:* 8 percent  
*Landform:* Depressions, bogs  
*Landform position (two-dimensional):* Toeslope  
*Landform position (three-dimensional):* Dip  
*Down-slope shape:* Concave  
*Across-slope shape:* Concave  
*Hydric soil rating:* Yes

### **Limerick**

*Percent of map unit:* 4 percent  
*Landform:* Terraces, alluvial flats  
*Landform position (two-dimensional):* Toeslope  
*Landform position (three-dimensional):* Tread, dip  
*Down-slope shape:* Linear  
*Across-slope shape:* Concave  
*Hydric soil rating:* Yes

## **253D—Hinckley loamy sand, 15 to 25 percent slopes**

### **Map Unit Setting**

*National map unit symbol:* 2svmc  
*Elevation:* 0 to 1,460 feet  
*Mean annual precipitation:* 36 to 71 inches  
*Mean annual air temperature:* 39 to 55 degrees F  
*Frost-free period:* 140 to 240 days  
*Farmland classification:* Not prime farmland

### **Map Unit Composition**

*Hinckley and similar soils:* 85 percent  
*Minor components:* 15 percent  
*Estimates are based on observations, descriptions, and transects of the mapunit.*

### **Description of Hinckley**

#### **Setting**

*Landform:* Kames, kame terraces, outwash deltas, outwash terraces, moraines, eskers, outwash plains  
*Landform position (two-dimensional):* Backslope  
*Landform position (three-dimensional):* Head slope, nose slope, side slope, crest, riser  
*Down-slope shape:* Concave, convex, linear  
*Across-slope shape:* Convex, linear, concave  
*Parent material:* Sandy and gravelly glaciofluvial deposits derived from gneiss and/or granite and/or schist

#### **Typical profile**

*Oe - 0 to 1 inches:* moderately decomposed plant material  
*A - 1 to 8 inches:* loamy sand  
*Bw1 - 8 to 11 inches:* gravelly loamy sand  
*Bw2 - 11 to 16 inches:* gravelly loamy sand

*BC - 16 to 19 inches: very gravelly loamy sand*

*C - 19 to 65 inches: very gravelly sand*

**Properties and qualities**

*Slope: 15 to 25 percent*

*Depth to restrictive feature: More than 80 inches*

*Drainage class: Excessively drained*

*Runoff class: Low*

*Capacity of the most limiting layer to transmit water*

*(Ksat): Moderately high to very high (1.42 to 99.90 in/hr)*

*Depth to water table: More than 80 inches*

*Frequency of flooding: None*

*Frequency of ponding: None*

*Maximum salinity: Nonsaline (0.0 to 1.9 mmhos/cm)*

*Available water supply, 0 to 60 inches: Low (about 3.1 inches)*

**Interpretive groups**

*Land capability classification (irrigated): None specified*

*Land capability classification (nonirrigated): 6e*

*Hydrologic Soil Group: A*

*Ecological site: F144AY022MA - Dry Outwash*

*Hydric soil rating: No*

**Minor Components**

**Merrimac**

*Percent of map unit: 8 percent*

*Landform: Eskers, outwash terraces, kames, outwash plains, moraines*

*Landform position (two-dimensional): Backslope*

*Landform position (three-dimensional): Head slope, nose slope, side slope, crest, riser*

*Down-slope shape: Convex*

*Across-slope shape: Convex*

*Hydric soil rating: No*

**Windsor**

*Percent of map unit: 5 percent*

*Landform: Kames, kame terraces, moraines, eskers, outwash deltas, outwash terraces, outwash plains*

*Landform position (two-dimensional): Backslope*

*Landform position (three-dimensional): Head slope, nose slope, side slope, crest, riser*

*Down-slope shape: Concave, convex, linear*

*Across-slope shape: Convex, linear, concave*

*Hydric soil rating: No*

**Sudbury**

*Percent of map unit: 2 percent*

*Landform: Eskers, kame terraces, outwash deltas, moraines, outwash plains, outwash terraces*

*Landform position (two-dimensional): Backslope, footslope*

*Landform position (three-dimensional): Base slope, tread*

*Down-slope shape: Convex, concave, linear*

*Across-slope shape:* Convex, concave, linear  
*Hydric soil rating:* No

## **256A—Deerfield loamy fine sand, 0 to 3 percent slopes**

### **Map Unit Setting**

*National map unit symbol:* 2xfg8  
*Elevation:* 0 to 1,100 feet  
*Mean annual precipitation:* 36 to 71 inches  
*Mean annual air temperature:* 39 to 55 degrees F  
*Frost-free period:* 145 to 240 days  
*Farmland classification:* Farmland of statewide importance

### **Map Unit Composition**

*Deerfield and similar soils:* 85 percent  
*Minor components:* 15 percent  
*Estimates are based on observations, descriptions, and transects of the mapunit.*

### **Description of Deerfield**

#### **Setting**

*Landform:* Outwash terraces, outwash deltas, outwash plains, kame terraces  
*Landform position (three-dimensional):* Tread  
*Down-slope shape:* Concave, convex, linear  
*Across-slope shape:* Convex, linear, concave  
*Parent material:* Sandy outwash derived from granite, gneiss, and/or quartzite

#### **Typical profile**

*Ap - 0 to 9 inches:* loamy fine sand  
*Bw - 9 to 25 inches:* loamy fine sand  
*BC - 25 to 33 inches:* fine sand  
*Cg - 33 to 60 inches:* sand

#### **Properties and qualities**

*Slope:* 0 to 3 percent  
*Depth to restrictive feature:* More than 80 inches  
*Drainage class:* Moderately well drained  
*Runoff class:* Negligible  
*Capacity of the most limiting layer to transmit water (Ksat):* Moderately high to very high (1.42 to 99.90 in/hr)  
*Depth to water table:* About 15 to 37 inches  
*Frequency of flooding:* None  
*Frequency of ponding:* None  
*Maximum salinity:* Nonsaline (0.0 to 1.9 mmhos/cm)  
*Sodium adsorption ratio, maximum:* 11.0  
*Available water supply, 0 to 60 inches:* Moderate (about 6.5 inches)

#### **Interpretive groups**

*Land capability classification (irrigated):* None specified

*Land capability classification (nonirrigated):* 2w  
*Hydrologic Soil Group:* A  
*Ecological site:* F144AY027MA - Moist Sandy Outwash  
*Hydric soil rating:* No

### **Minor Components**

#### **Windsor**

*Percent of map unit:* 7 percent  
*Landform:* Outwash terraces, kame terraces, outwash deltas, outwash plains  
*Landform position (three-dimensional):* Tread  
*Down-slope shape:* Concave, convex, linear  
*Across-slope shape:* Convex, linear, concave  
*Hydric soil rating:* No

#### **Wareham**

*Percent of map unit:* 5 percent  
*Landform:* Drainageways, depressions  
*Down-slope shape:* Concave  
*Across-slope shape:* Concave  
*Hydric soil rating:* Yes

#### **Sudbury**

*Percent of map unit:* 2 percent  
*Landform:* Outwash plains, kame terraces, outwash deltas, outwash terraces  
*Landform position (three-dimensional):* Tread  
*Down-slope shape:* Concave, convex, linear  
*Across-slope shape:* Convex, linear, concave  
*Hydric soil rating:* No

#### **Ninigret**

*Percent of map unit:* 1 percent  
*Landform:* Kame terraces, outwash plains, outwash terraces  
*Landform position (three-dimensional):* Tread  
*Down-slope shape:* Convex, linear  
*Across-slope shape:* Convex, concave  
*Hydric soil rating:* No

## **602—Urban land**

### **Map Unit Setting**

*National map unit symbol:* 9950  
*Elevation:* 0 to 3,000 feet  
*Mean annual precipitation:* 32 to 50 inches  
*Mean annual air temperature:* 45 to 50 degrees F  
*Frost-free period:* 110 to 200 days  
*Farmland classification:* Not prime farmland

### **Map Unit Composition**

*Urban land:* 85 percent  
*Minor components:* 15 percent

*Estimates are based on observations, descriptions, and transects of the mapunit.*

### **Description of Urban Land**

#### **Setting**

*Landform position (two-dimensional):* Footslope

*Landform position (three-dimensional):* Base slope

*Down-slope shape:* Linear

*Across-slope shape:* Linear

*Parent material:* Excavated and filled land

### **Minor Components**

#### **Udorthents, loamy**

*Percent of map unit:* 5 percent

*Hydric soil rating:* No

#### **Rock outcrop**

*Percent of map unit:* 5 percent

*Landform:* Ledges

*Landform position (two-dimensional):* Summit

*Landform position (three-dimensional):* Head slope

*Down-slope shape:* Concave

*Across-slope shape:* Concave

#### **Udorthents, wet substratum**

*Percent of map unit:* 5 percent

*Hydric soil rating:* No

## **626B—Merrimac-Urban land complex, 0 to 8 percent slopes**

### **Map Unit Setting**

*National map unit symbol:* 2tyr9

*Elevation:* 0 to 820 feet

*Mean annual precipitation:* 36 to 71 inches

*Mean annual air temperature:* 39 to 55 degrees F

*Frost-free period:* 140 to 250 days

*Farmland classification:* Not prime farmland

### **Map Unit Composition**

*Merrimac and similar soils:* 45 percent

*Urban land:* 40 percent

*Minor components:* 15 percent

*Estimates are based on observations, descriptions, and transects of the mapunit.*

### **Description of Merrimac**

#### **Setting**

*Landform:* Outwash plains, outwash terraces, moraines, eskers, kames

*Landform position (two-dimensional):* Summit, shoulder, backslope, footslope

*Landform position (three-dimensional):* Crest, side slope, riser, tread

*Down-slope shape:* Convex

*Across-slope shape:* Convex

*Parent material:* Loamy glaciofluvial deposits derived from granite, schist, and gneiss over sandy and gravelly glaciofluvial deposits derived from granite, schist, and gneiss

#### **Typical profile**

*Ap - 0 to 10 inches:* fine sandy loam

*Bw1 - 10 to 22 inches:* fine sandy loam

*Bw2 - 22 to 26 inches:* stratified gravel to gravelly loamy sand

*2C - 26 to 65 inches:* stratified gravel to very gravelly sand

#### **Properties and qualities**

*Slope:* 0 to 8 percent

*Depth to restrictive feature:* More than 80 inches

*Drainage class:* Somewhat excessively drained

*Runoff class:* Very low

*Capacity of the most limiting layer to transmit water*

*(Ksat):* Moderately high to very high (1.42 to 99.90 in/hr)

*Depth to water table:* More than 80 inches

*Frequency of flooding:* None

*Frequency of ponding:* None

*Calcium carbonate, maximum content:* 2 percent

*Maximum salinity:* Nonsaline (0.0 to 1.4 mmhos/cm)

*Sodium adsorption ratio, maximum:* 1.0

*Available water supply, 0 to 60 inches:* Low (about 4.6 inches)

#### **Interpretive groups**

*Land capability classification (irrigated):* None specified

*Land capability classification (nonirrigated):* 2e

*Hydrologic Soil Group:* A

*Ecological site:* F144AY022MA - Dry Outwash

*Hydric soil rating:* No

#### **Description of Urban Land**

##### **Typical profile**

*M - 0 to 10 inches:* cemented material

##### **Properties and qualities**

*Slope:* 0 to 8 percent

*Depth to restrictive feature:* 0 inches to manufactured layer

*Runoff class:* Very high

*Capacity of the most limiting layer to transmit water (Ksat):* Very low

*(0.00 to 0.00 in/hr)*

*Available water supply, 0 to 60 inches:* Very low (about 0.0 inches)

##### **Interpretive groups**

*Land capability classification (irrigated):* None specified

*Land capability classification (nonirrigated):* 8

*Hydrologic Soil Group:* D  
*Hydric soil rating:* Unranked

### **Minor Components**

#### **Windsor**

*Percent of map unit:* 5 percent  
*Landform:* Outwash terraces, dunes, outwash plains, deltas  
*Landform position (three-dimensional):* Tread, riser  
*Down-slope shape:* Linear, convex  
*Across-slope shape:* Linear, convex  
*Hydric soil rating:* No

#### **Sudbury**

*Percent of map unit:* 5 percent  
*Landform:* Deltas, terraces, outwash plains  
*Landform position (two-dimensional):* Footslope  
*Landform position (three-dimensional):* Tread, dip  
*Down-slope shape:* Concave  
*Across-slope shape:* Linear  
*Hydric soil rating:* No

#### **Hinckley**

*Percent of map unit:* 5 percent  
*Landform:* Deltas, kames, eskers, outwash plains  
*Landform position (two-dimensional):* Summit, shoulder, backslope  
*Landform position (three-dimensional):* Head slope, nose slope, crest, side slope, rise  
*Down-slope shape:* Convex  
*Across-slope shape:* Convex, linear  
*Hydric soil rating:* No

## **656—Udorthents-Urban land complex**

### **Map Unit Setting**

*National map unit symbol:* 995k  
*Elevation:* 0 to 3,000 feet  
*Mean annual precipitation:* 32 to 54 inches  
*Mean annual air temperature:* 43 to 54 degrees F  
*Frost-free period:* 110 to 240 days  
*Farmland classification:* Not prime farmland

### **Map Unit Composition**

*Udorthents and similar soils:* 45 percent  
*Urban land:* 35 percent  
*Minor components:* 20 percent  
*Estimates are based on observations, descriptions, and transects of the mapunit.*

## Description of Udorthents

### Setting

*Parent material:* Loamy alluvium and/or sandy glaciofluvial deposits and/or loamy glaciolacustrine deposits and/or loamy marine deposits and/or loamy basal till and/or loamy lodgment till

### Properties and qualities

*Slope:* 0 to 15 percent

*Depth to restrictive feature:* More than 80 inches

*Depth to water table:* More than 80 inches

*Frequency of flooding:* None

*Frequency of ponding:* None

## Description of Urban Land

### Setting

*Landform position (two-dimensional):* Footslope

*Landform position (three-dimensional):* Base slope

*Down-slope shape:* Linear

*Across-slope shape:* Linear

*Parent material:* Excavated and filled land

## Minor Components

### Canton

*Percent of map unit:* 10 percent

*Landform:* Hills

*Landform position (two-dimensional):* Backslope, toeslope

*Landform position (three-dimensional):* Side slope, base slope

*Down-slope shape:* Linear

*Across-slope shape:* Convex

*Hydric soil rating:* No

### Merrimac

*Percent of map unit:* 5 percent

*Landform:* Terraces, plains

*Landform position (two-dimensional):* Shoulder

*Landform position (three-dimensional):* Tread, rise

*Down-slope shape:* Convex

*Across-slope shape:* Convex

*Hydric soil rating:* No

### Paxton

*Percent of map unit:* 5 percent

*Landform:* Hillslopes

*Landform position (two-dimensional):* Summit, backslope

*Landform position (three-dimensional):* Head slope, side slope

*Down-slope shape:* Convex

*Across-slope shape:* Convex

*Hydric soil rating:* No

## **Data Source Information**

Soil Survey Area: Middlesex County, Massachusetts  
Survey Area Data: Version 22, Sep 9, 2022

**Attachment 2**  
**Pre-Development Hydrologic Analysis**

---

## 2063.27 Pre-Development Hydrology Calculation Summary

### Objective

To determine the pre-development peak rates of runoff and total runoff volumes to the respective design points associated with the 2, 10, 25 & 100-year storm events.

### Conclusion

| Storm Event | 2-Year Runoff |              | 10-Year Runoff |              | 25-Year Runoff |              | 100-Year Runoff |              |
|-------------|---------------|--------------|----------------|--------------|----------------|--------------|-----------------|--------------|
|             | Peak Rate     | Total Volume | Peak Rate      | Total Volume | Peak Rate      | Total Volume | Peak Rate       | Total Volume |
| DP-1        | 2.77 cfs      | 0.355 af     | 7.98 cfs       | 0.881 af     | 12.77 cfs      | 1.370 af     | 23.52 cfs       | 2.491 af     |
| DP-2        | 0.07 cfs      | 0.097 af     | 0.21 cfs       | 0.348 af     | 0.21 cfs       | 0.394 af     | 0.23 cfs        | 0.447 af     |
| DP-3        | 0.70 cfs      | 0.056 af     | 1.53 cfs       | 0.118 af     | 2.23 cfs       | 0.173 af     | 3.72 cfs        | 0.292 af     |
| DP-4        | 0.28 cfs      | 0.023 af     | 0.68 cfs       | 0.053 af     | 1.03 cfs       | 0.080 af     | 1.79 cfs        | 0.140 af     |
| DP-5        | 0.70 cfs      | 0.152 af     | 1.54 cfs       | 0.466 af     | 2.26 cfs       | 0.567 af     | 3.87 cfs        | 0.739 af     |
| DP-6        | 0.98 cfs      | 0.176 af     | 2.21 cfs       | 0.519 af     | 3.29 cfs       | 0.647 af     | 5.67 cfs        | 0.879 af     |

### Calculation Methods

1. Runoff curve numbers (CN) and times-of-concentration (Tc) are based on TR-55 methodology.
2. Peak rates of runoff and total runoff volumes were computed with HydroCAD (version 10.20-3c).
3. Subcatchment areas were imported into HydroCAD from AutoCAD Civil 3D.

### Assumptions

1. A minimum Tc of 6.0 minutes was used, where applicable.
2. Storm events are NRCC 24-hr D rainfall distribution for Concord, Massachusetts.
3. Surface cover types and watershed boundaries were estimated based on B+T topographic base information.
4. For areas with dual Hydrologic Soil Group (HSG) classifications, wetlands were considered HSG D.
5. Soils mapped as "Udorthents" and/or "Urban Land" were considered HSG A soils, given the HSG of adjacent mapped soils.
6. Design Points are as follows:
  - o Interim Design Points
    - DP-1 - To Existing Pond
    - DP-2 - West to Conservation Restriction
    - DP-3 - Northwest to rear of #300 Baker Avenue
  - o Primary Design Points
    - DP-4 - To Existing Stormwater Infrastructure East of #300 Baker Avenue
    - DP-5 - To Bordering Vegetative Wetlands to the West
    - DP-6 - To Assabet River (Confluence of DP-4 & DP-5)

#### Corporate Office

144 Turnpike Road  
Southborough, MA 01772

[bealsandthomas.com](http://bealsandthomas.com) T 508.366.0560 F 508.366.4391

#### Regional Office

32 Court Street  
Plymouth, MA 02360

### Sources of Data/ Equations

1. Existing Conditions Watershed Map (dated 8/22/2023) prepared by Beals and Thomas, Inc. (206327P123A-001).
2. Topographic AutoCAD base file 206326B017C generated by Beals and Thomas, Inc.
3. Pre-development HydroCAD file 206327HC002A generated by Beals and Thomas, Inc.
4. Existing pond model from HydroCAD file 206317HC001A (Pond P-7: Pond 7) included in the Proposed Hotel Development Stormwater Management Report (206317RP001B) prepared by Beals and Thomas, Inc. dated 9/5/2014.
5. TR-55 Urban Hydrology for Small Watersheds, SCS, 1986.
6. Storm event rainfall sourced from HydroCAD 10.20-3c.
7. Hydrologic Soil Groups per MassMapper GIS data layers and USDA NRCS Web Soil Survey (both downloaded August 5, 2023).
8. Massachusetts Department of Environmental Protection Stormwater Handbook dated February 2008.

### List of Attachments

1. NOVO Riverside Commons Existing Conditions Watershed Map (Figure 1)
2. Pre-Development Hydrologic Calculations.

| REV | CALC. BY | DATE | CHECKED BY | DATE | APPROVED BY | DATE |
|-----|----------|------|------------|------|-------------|------|
| 0   |          |      |            |      |             |      |
|     |          |      |            |      |             |      |
|     |          |      |            |      |             |      |

206327CS002A

**Corporate Office**

144 Turnpike Road  
 Southborough, MA 01772

[bealsandthomas.com](http://bealsandthomas.com) T 508.366.0560 F 508.366.4391

**Regional Office**

32 Court Street  
 Plymouth, MA 02360

## Attachments

---

# NOVO Riverside Commons

Concord, Massachusetts

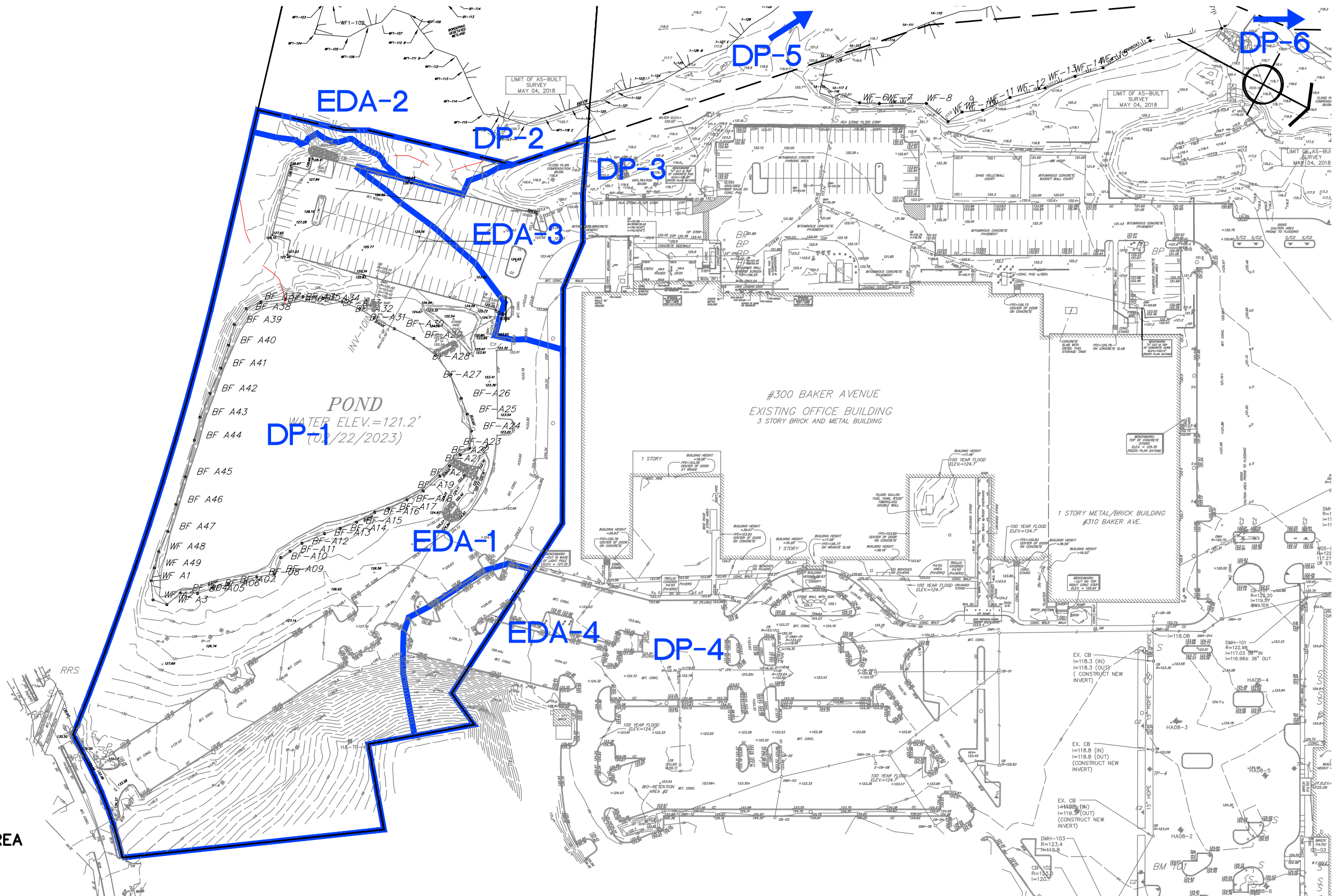

**—** DRAINAGE AREA  
**—** Tc PATH

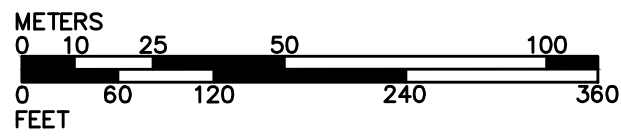

B+T Drawing No. 206327P123A-001 Date: 8/22/2023 Scale: 1" = 120'

**Existing Conditions**  
 Watershed Map

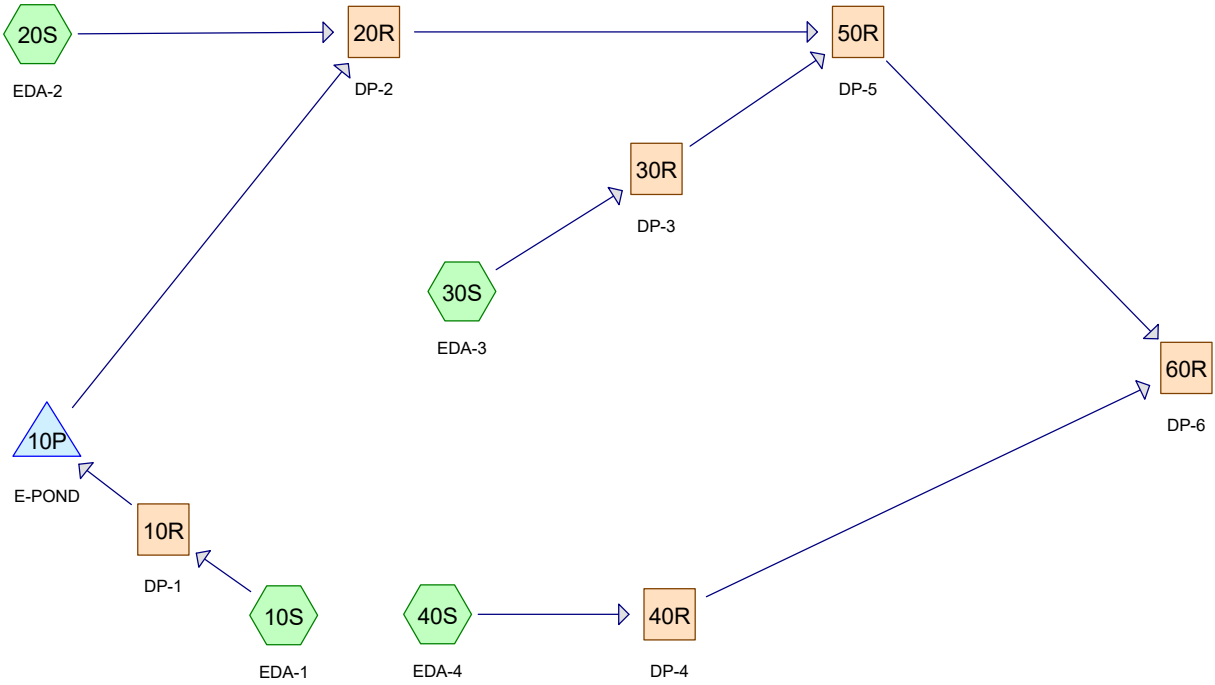

PRE-DEVELOPMENT

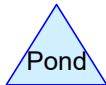
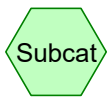

**Routing Diagram for 206327HC002A**  
 Prepared by Beals & Thomas Inc, Printed 8/22/2023  
 HydroCAD® 10.20-3c s/n 04493 © 2023 HydroCAD Software Solutions LLC

**206327HC002A**

Prepared by Beals &amp; Thomas Inc

Printed 8/22/2023

HydroCAD® 10.20-3c s/n 04493 © 2023 HydroCAD Software Solutions LLC

Page 2

**Rainfall Events Listing (selected events)**

| Event# | Event Name | Storm Type | Curve | Mode    | Duration (hours) | B/B | Depth (inches) | AMC |
|--------|------------|------------|-------|---------|------------------|-----|----------------|-----|
| 1      | 2-Year     | NRCC 24-hr | D     | Default | 24.00            | 1   | 3.09           | 2   |
| 2      | 10-Year    | NRCC 24-hr | D     | Default | 24.00            | 1   | 4.65           | 2   |
| 3      | 25-Year    | NRCC 24-hr | D     | Default | 24.00            | 1   | 5.87           | 2   |
| 4      | 100-Year   | NRCC 24-hr | D     | Default | 24.00            | 1   | 8.36           | 2   |

**206327HC002A**

Prepared by Beals &amp; Thomas Inc

Printed 8/22/2023

HydroCAD® 10.20-3c s/n 04493 © 2023 HydroCAD Software Solutions LLC

Page 3

**Area Listing (selected nodes)**

| Area<br>(acres) | CN        | Description<br>(subcatchment-numbers)              |
|-----------------|-----------|--|
| 2.528           | 39        | >75% Grass cover, Good, HSG A (10S, 20S, 30S, 40S) |
| 2.151           | 98        | Paved parking, HSG A (10S, 30S, 40S)               |
| 1.724           | 98        | Water Surface, HSG D (10S)                         |
| 1.416           | 30        | Woods, Good, HSG A (10S, 20S, 30S, 40S)            |
| 0.132           | 77        | Woods, Good, HSG D (10S)                           |
| <b>7.951</b>    | <b>67</b> | <b>TOTAL AREA</b>                                  |

**206327HC002A**

Prepared by Beals &amp; Thomas Inc

Printed 8/22/2023

HydroCAD® 10.20-3c s/n 04493 © 2023 HydroCAD Software Solutions LLC

Page 4

**Soil Listing (selected nodes)**

| Area<br>(acres) | Soil<br>Group | Subcatchment<br>Numbers |
|-----------------|---------------|-------------------------|
| 6.095           | HSG A         | 10S, 20S, 30S, 40S      |
| 0.000           | HSG B         |                         |
| 0.000           | HSG C         |                         |
| 1.856           | HSG D         | 10S                     |
| 0.000           | Other         |                         |
| <b>7.951</b>    |               | <b>TOTAL AREA</b>       |

**206327HC002A**

Prepared by Beals &amp; Thomas Inc

Printed 8/22/2023

HydroCAD® 10.20-3c s/n 04493 © 2023 HydroCAD Software Solutions LLC

Page 5

**Ground Covers (selected nodes)**

| HSG-A<br>(acres) | HSG-B<br>(acres) | HSG-C<br>(acres) | HSG-D<br>(acres) | Other<br>(acres) | Total<br>(acres) | Ground<br>Cover        | Subcatchment<br>Numbers     |
|------------------|------------------|------------------|------------------|------------------|------------------|------------------------|-----------------------------|
| 2.528            | 0.000            | 0.000            | 0.000            | 0.000            | 2.528            | >75% Grass cover, Good | 10S,<br>20S,<br>30S,<br>40S |
| 2.151            | 0.000            | 0.000            | 0.000            | 0.000            | 2.151            | Paved parking          | 10S,<br>30S,<br>40S         |
| 0.000            | 0.000            | 0.000            | 1.724            | 0.000            | 1.724            | Water Surface          | 10S                         |
| 1.416            | 0.000            | 0.000            | 0.132            | 0.000            | 1.548            | Woods, Good            | 10S,<br>20S,<br>30S,<br>40S |
| <b>6.095</b>     | <b>0.000</b>     | <b>0.000</b>     | <b>1.856</b>     | <b>0.000</b>     | <b>7.951</b>     | <b>TOTAL AREA</b>      |                             |

**206327HC002A**

Prepared by Beals &amp; Thomas Inc

HydroCAD® 10.20-3c s/n 04493 © 2023 HydroCAD Software Solutions LLC

2063.27 Pre-Development  
NRCC 24-hr D 2-Year Rainfall=3.09"

Printed 8/22/2023

Page 6

Time span=0.00-36.00 hrs, dt=0.05 hrs, 721 points  
 Runoff by SCS TR-20 method, UH=SCS, Weighted-CN  
 Reach routing by Stor-Ind+Trans method - Pond routing by Stor-Ind method

|   |  |
|---|--|
| <b>Subcatchment 10S: EDA-1</b>  | Runoff Area=6.760 ac 48.62% Impervious Runoff Depth=0.63"<br>Flow Length=141' Tc=15.5 min CN=67 Runoff=2.77 cfs 0.355 af                   |
| <b>Subcatchment 20S: EDA-2</b>  | Runoff Area=0.195 ac 0.00% Impervious Runoff Depth=0.00"<br>Flow Length=117' Tc=10.5 min CN=31 Runoff=0.00 cfs 0.000 af                    |
| <b>Subcatchment 30S: EDA-3</b>  | Runoff Area=0.654 ac 61.17% Impervious Runoff Depth=1.02"<br>Tc=6.0 min CN=75 Runoff=0.70 cfs 0.056 af                                     |
| <b>Subcatchment 40S: EDA-4</b>  | Runoff Area=0.342 ac 55.03% Impervious Runoff Depth=0.81"<br>Tc=6.0 min CN=71 Runoff=0.28 cfs 0.023 af                                     |
| <b>Reach 10R: DP-1</b>  | Inflow=2.77 cfs 0.355 af<br>Outflow=2.77 cfs 0.355 af  |
| <b>Reach 20R: DP-2</b>  | Inflow=0.07 cfs 0.097 af<br>Outflow=0.07 cfs 0.097 af  |
| <b>Reach 30R: DP-3</b>  | Inflow=0.70 cfs 0.056 af<br>Outflow=0.70 cfs 0.056 af  |
| <b>Reach 40R: DP-4</b>  | Inflow=0.28 cfs 0.023 af<br>Outflow=0.28 cfs 0.023 af  |
| <b>Reach 50R: DP-5</b>  | Inflow=0.70 cfs 0.152 af<br>Outflow=0.70 cfs 0.152 af  |
| <b>Reach 60R: DP-6</b>  | Inflow=0.98 cfs 0.176 af<br>Outflow=0.98 cfs 0.176 af  |
| <b>Pond 10P: E-POND</b>   | Peak Elev=121.58' Storage=0.312 af Inflow=2.77 cfs 0.355 af<br>4.0" Round Culvert n=0.012 L=275.0' S=0.0090 ' /' Outflow=0.07 cfs 0.097 af |
| <b>Total Runoff Area = 7.951 ac Runoff Volume = 0.434 af Average Runoff Depth = 0.65"</b> |  |
| <b>51.26% Pervious = 4.076 ac 48.74% Impervious = 3.875 ac</b>                            |  |

**206327HC002A**

Prepared by Beals &amp; Thomas Inc

HydroCAD® 10.20-3c s/n 04493 © 2023 HydroCAD Software Solutions LLC

2063.27 Pre-Development  
NRCC 24-hr D 10-Year Rainfall=4.65"

Printed 8/22/2023

Page 7

Time span=0.00-36.00 hrs, dt=0.05 hrs, 721 points  
 Runoff by SCS TR-20 method, UH=SCS, Weighted-CN  
 Reach routing by Stor-Ind+Trans method - Pond routing by Stor-Ind method

|                                |   |
|--------------------------------|---|
| <b>Subcatchment 10S: EDA-1</b> | Runoff Area=6.760 ac 48.62% Impervious Runoff Depth=1.56"<br>Flow Length=141' Tc=15.5 min CN=67 Runoff=7.98 cfs 0.881 af                |
| <b>Subcatchment 20S: EDA-2</b> | Runoff Area=0.195 ac 0.00% Impervious Runoff Depth=0.00"<br>Flow Length=117' Tc=10.5 min CN=31 Runoff=0.00 cfs 0.000 af                 |
| <b>Subcatchment 30S: EDA-3</b> | Runoff Area=0.654 ac 61.17% Impervious Runoff Depth=2.17"<br>Tc=6.0 min CN=75 Runoff=1.53 cfs 0.118 af                                  |
| <b>Subcatchment 40S: EDA-4</b> | Runoff Area=0.342 ac 55.03% Impervious Runoff Depth=1.86"<br>Tc=6.0 min CN=71 Runoff=0.68 cfs 0.053 af                                  |
| <b>Reach 10R: DP-1</b>         | Inflow=7.98 cfs 0.881 af<br>Outflow=7.98 cfs 0.881 af   |
| <b>Reach 20R: DP-2</b>         | Inflow=0.21 cfs 0.348 af<br>Outflow=0.21 cfs 0.348 af   |
| <b>Reach 30R: DP-3</b>         | Inflow=1.53 cfs 0.118 af<br>Outflow=1.53 cfs 0.118 af   |
| <b>Reach 40R: DP-4</b>         | Inflow=0.68 cfs 0.053 af<br>Outflow=0.68 cfs 0.053 af   |
| <b>Reach 50R: DP-5</b>         | Inflow=1.54 cfs 0.466 af<br>Outflow=1.54 cfs 0.466 af   |
| <b>Reach 60R: DP-6</b>         | Inflow=2.21 cfs 0.519 af<br>Outflow=2.21 cfs 0.519 af   |
| <b>Pond 10P: E-POND</b>        | Peak Elev=121.81' Storage=0.709 af Inflow=7.98 cfs 0.881 af<br>4.0" Round Culvert n=0.012 L=275.0' S=0.0090 ' Outflow=0.20 cfs 0.348 af |

**Total Runoff Area = 7.951 ac Runoff Volume = 1.052 af Average Runoff Depth = 1.59"**  
**51.26% Pervious = 4.076 ac 48.74% Impervious = 3.875 ac**

**206327HC002A**

Prepared by Beals &amp; Thomas Inc

HydroCAD® 10.20-3c s/n 04493 © 2023 HydroCAD Software Solutions LLC

2063.27 Pre-Development  
NRCC 24-hr D 25-Year Rainfall=5.87"

Printed 8/22/2023

Page 8

Time span=0.00-36.00 hrs, dt=0.05 hrs, 721 points  
 Runoff by SCS TR-20 method, UH=SCS, Weighted-CN  
 Reach routing by Stor-Ind+Trans method - Pond routing by Stor-Ind method

|   |   |
|---|---|
| <b>Subcatchment 10S: EDA-1</b>  | Runoff Area=6.760 ac 48.62% Impervious Runoff Depth=2.43"<br>Flow Length=141' Tc=15.5 min CN=67 Runoff=12.77 cfs 1.370 af                 |
| <b>Subcatchment 20S: EDA-2</b>  | Runoff Area=0.195 ac 0.00% Impervious Runoff Depth=0.08"<br>Flow Length=117' Tc=10.5 min CN=31 Runoff=0.00 cfs 0.001 af                   |
| <b>Subcatchment 30S: EDA-3</b>  | Runoff Area=0.654 ac 61.17% Impervious Runoff Depth=3.17"<br>Tc=6.0 min CN=75 Runoff=2.23 cfs 0.173 af                                    |
| <b>Subcatchment 40S: EDA-4</b>  | Runoff Area=0.342 ac 55.03% Impervious Runoff Depth=2.79"<br>Tc=6.0 min CN=71 Runoff=1.03 cfs 0.080 af                                    |
| <b>Reach 10R: DP-1</b>  | Inflow=12.77 cfs 1.370 af<br>Outflow=12.77 cfs 1.370 af   |
| <b>Reach 20R: DP-2</b>  | Inflow=0.21 cfs 0.394 af<br>Outflow=0.21 cfs 0.394 af   |
| <b>Reach 30R: DP-3</b>  | Inflow=2.23 cfs 0.173 af<br>Outflow=2.23 cfs 0.173 af   |
| <b>Reach 40R: DP-4</b>  | Inflow=1.03 cfs 0.080 af<br>Outflow=1.03 cfs 0.080 af   |
| <b>Reach 50R: DP-5</b>  | Inflow=2.26 cfs 0.567 af<br>Outflow=2.26 cfs 0.567 af   |
| <b>Reach 60R: DP-6</b>  | Inflow=3.29 cfs 0.647 af<br>Outflow=3.29 cfs 0.647 af   |
| <b>Pond 10P: E-POND</b>   | Peak Elev=122.06' Storage=1.172 af Inflow=12.77 cfs 1.370 af<br>4.0" Round Culvert n=0.012 L=275.0' S=0.0090 '/ Outflow=0.21 cfs 0.393 af |
| <b>Total Runoff Area = 7.951 ac Runoff Volume = 1.624 af Average Runoff Depth = 2.45"</b> |   |
| <b>51.26% Pervious = 4.076 ac 48.74% Impervious = 3.875 ac</b>                            |   |

**206327HC002A**

Prepared by Beals &amp; Thomas Inc

HydroCAD® 10.20-3c s/n 04493 © 2023 HydroCAD Software Solutions LLC

2063.27 Pre-Development  
NRCC 24-hr D 100-Year Rainfall=8.36"

Printed 8/22/2023

Page 9

Time span=0.00-36.00 hrs, dt=0.05 hrs, 721 points  
 Runoff by SCS TR-20 method, UH=SCS, Weighted-CN  
 Reach routing by Stor-Ind+Trans method - Pond routing by Stor-Ind method

|   |   |
|---|---|
| <b>Subcatchment 10S: EDA-1</b>  | Runoff Area=6.760 ac 48.62% Impervious Runoff Depth=4.42"<br>Flow Length=141' Tc=15.5 min CN=67 Runoff=23.52 cfs 2.491 af                 |
| <b>Subcatchment 20S: EDA-2</b>  | Runoff Area=0.195 ac 0.00% Impervious Runoff Depth=0.58"<br>Flow Length=117' Tc=10.5 min CN=31 Runoff=0.02 cfs 0.009 af                   |
| <b>Subcatchment 30S: EDA-3</b>  | Runoff Area=0.654 ac 61.17% Impervious Runoff Depth=5.37"<br>Tc=6.0 min CN=75 Runoff=3.72 cfs 0.292 af                                    |
| <b>Subcatchment 40S: EDA-4</b>  | Runoff Area=0.342 ac 55.03% Impervious Runoff Depth=4.89"<br>Tc=6.0 min CN=71 Runoff=1.79 cfs 0.140 af                                    |
| <b>Reach 10R: DP-1</b>  | Inflow=23.52 cfs 2.491 af<br>Outflow=23.52 cfs 2.491 af   |
| <b>Reach 20R: DP-2</b>  | Inflow=0.23 cfs 0.447 af<br>Outflow=0.23 cfs 0.447 af   |
| <b>Reach 30R: DP-3</b>  | Inflow=3.72 cfs 0.292 af<br>Outflow=3.72 cfs 0.292 af   |
| <b>Reach 40R: DP-4</b>  | Inflow=1.79 cfs 0.140 af<br>Outflow=1.79 cfs 0.140 af   |
| <b>Reach 50R: DP-5</b>  | Inflow=3.87 cfs 0.739 af<br>Outflow=3.87 cfs 0.739 af   |
| <b>Reach 60R: DP-6</b>  | Inflow=5.67 cfs 0.879 af<br>Outflow=5.67 cfs 0.879 af   |
| <b>Pond 10P: E-POND</b>   | Peak Elev=122.64' Storage=2.267 af Inflow=23.52 cfs 2.491 af<br>4.0" Round Culvert n=0.012 L=275.0' S=0.0090 '/ Outflow=0.22 cfs 0.437 af |
| <b>Total Runoff Area = 7.951 ac Runoff Volume = 2.932 af Average Runoff Depth = 4.43"</b> |   |
| <b>51.26% Pervious = 4.076 ac 48.74% Impervious = 3.875 ac</b>                            |   |

**206327HC002A**

Prepared by Beals &amp; Thomas Inc

HydroCAD® 10.20-3c s/n 04493 © 2023 HydroCAD Software Solutions LLC

2063.27 Pre-Development  
NRCC 24-hr D 100-Year Rainfall=8.36"

Printed 8/22/2023

Page 10

**Summary for Subcatchment 10S: EDA-1**

Runoff = 23.52 cfs @ 12.24 hrs, Volume= 2.491 af, Depth= 4.42"  
 Routed to Reach 10R : DP-1

Runoff by SCS TR-20 method, UH=SCS, Weighted-CN, Time Span= 0.00-36.00 hrs, dt= 0.05 hrs  
 NRCC 24-hr D 100-Year Rainfall=8.36"

| Area (ac) | CN | Description                   |
|-----------|----|-------------------------------|
| 2.115     | 39 | >75% Grass cover, Good, HSG A |
| 1.563     | 98 | Paved parking, HSG A          |
| 1.724     | 98 | Water Surface, HSG D          |
| 1.226     | 30 | Woods, Good, HSG A            |
| 0.132     | 77 | Woods, Good, HSG D            |
| 6.760     | 67 | Weighted Average              |
| 3.473     |    | 51.38% Pervious Area          |
| 3.287     |    | 48.62% Impervious Area        |

| Tc (min) | Length (feet) | Slope (ft/ft) | Velocity (ft/sec) | Capacity (cfs) | Description   |
|----------|---------------|---------------|-------------------|----------------|---|
| 14.5     | 50            | 0.0140        | 0.06              |                | <b>Sheet Flow, SF</b><br>Woods: Light underbrush n= 0.400 P2= 3.09" |
| 0.9      | 67            | 0.0569        | 1.19              |                | <b>Shallow Concentrated Flow, SCF-1</b><br>Woodland Kv= 5.0 fps     |
| 0.1      | 24            | 0.2962        | 2.72              |                | <b>Shallow Concentrated Flow, SCF-2</b><br>Woodland Kv= 5.0 fps     |
| 15.5     | 141           | Total         |                   |                |   |

Subcatchment 10S: EDA-1

Hydrograph

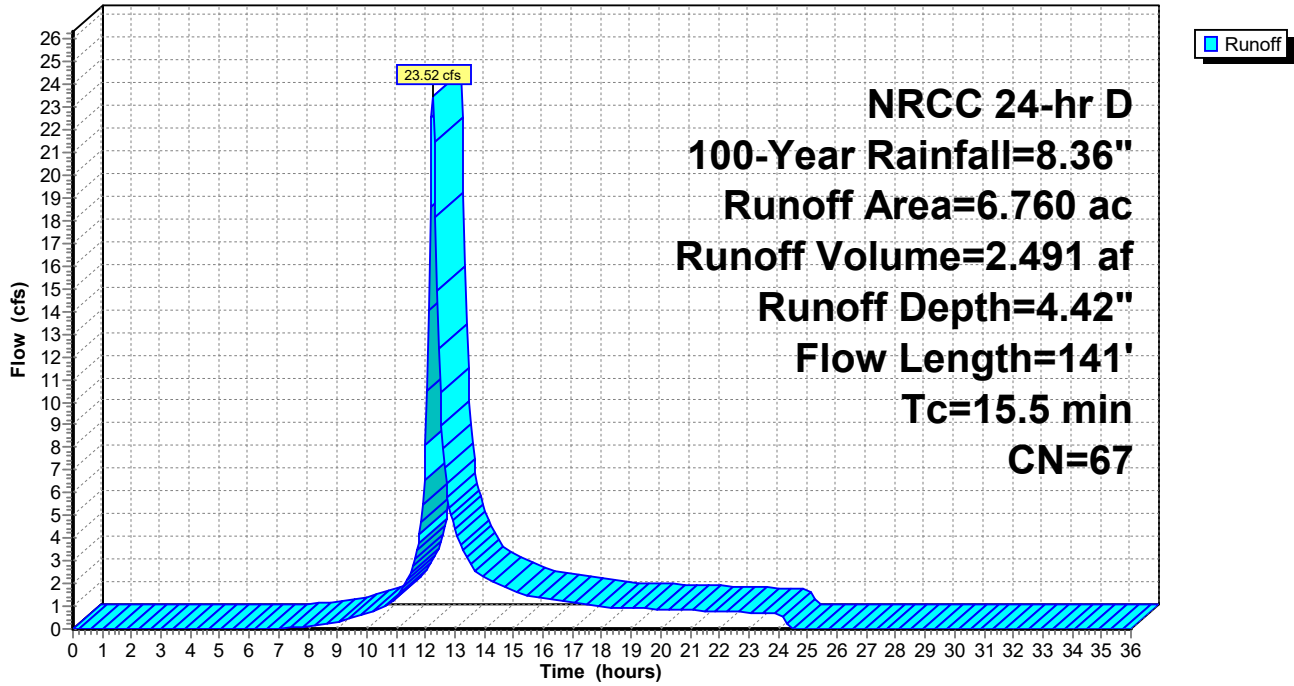

**206327HC002A**

Prepared by Beals & Thomas Inc

HydroCAD® 10.20-3c s/n 04493 © 2023 HydroCAD Software Solutions LLC

**Summary for Subcatchment 20S: EDA-2**

Runoff = 0.02 cfs @ 12.37 hrs, Volume= 0.009 af, Depth= 0.58"  
 Routed to Reach 20R : DP-2

Runoff by SCS TR-20 method, UH=SCS, Weighted-CN, Time Span= 0.00-36.00 hrs, dt= 0.05 hrs  
 NRCC 24-hr D 100-Year Rainfall=8.36"

| Area (ac) | CN | Description                   |
|-----------|----|-------------------------------|
| 0.026     | 39 | >75% Grass cover, Good, HSG A |
| 0.169     | 30 | Woods, Good, HSG A            |
| 0.195     | 31 | Weighted Average              |
| 0.195     |    | 100.00% Pervious Area         |

| Tc (min) | Length (feet) | Slope (ft/ft) | Velocity (ft/sec) | Capacity (cfs) | Description  |
|----------|---------------|---------------|-------------------|----------------|--|
| 9.5      | 50            | 0.0400        | 0.09              |                | <b>Sheet Flow, SHT</b><br>Woods: Light underbrush n= 0.400 P2= 3.09" |
| 1.0      | 67            | 0.0505        | 1.12              |                | <b>Shallow Concentrated Flow, SCF-1</b><br>Woodland Kv= 5.0 fps      |
| 10.5     | 117           | Total         |                   |                |  |

**Subcatchment 20S: EDA-2**

Hydrograph

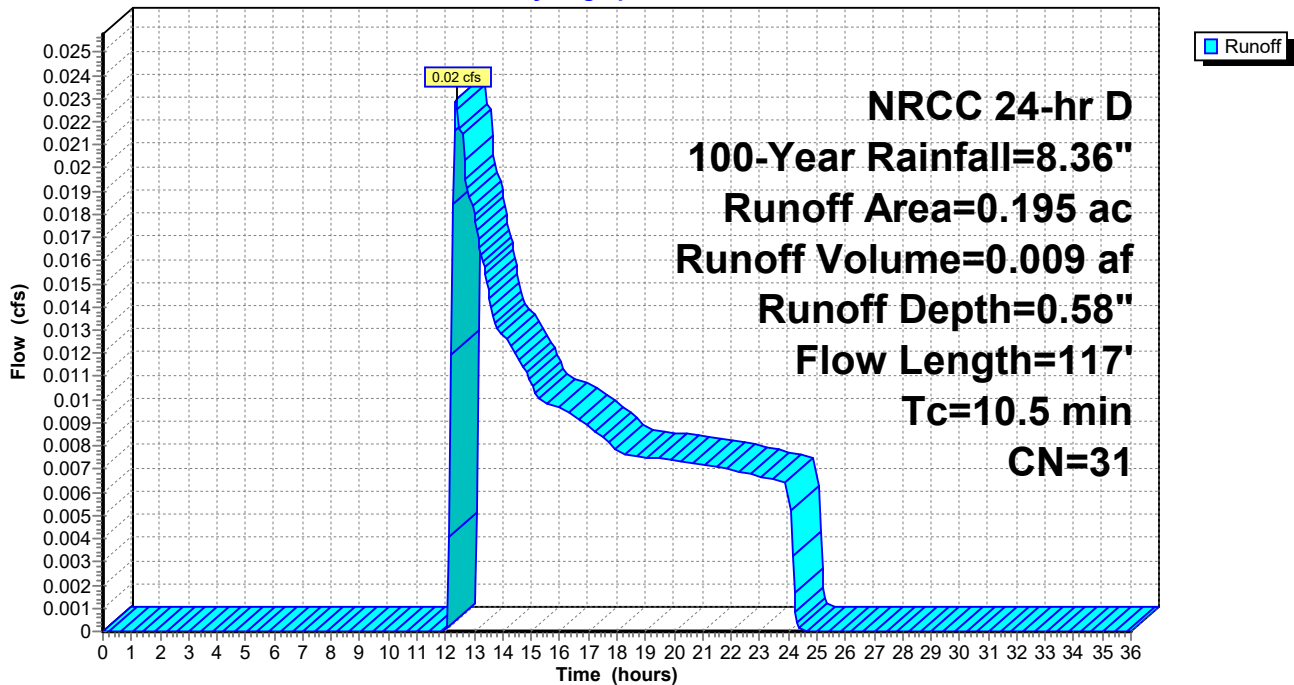

**206327HC002A**

Prepared by Beals & Thomas Inc

HydroCAD® 10.20-3c s/n 04493 © 2023 HydroCAD Software Solutions LLC

2063.27 Pre-Development  
NRCC 24-hr D 100-Year Rainfall=8.36"

Printed 8/22/2023

Page 13

**Summary for Subcatchment 30S: EDA-3**

Runoff = 3.72 cfs @ 12.13 hrs, Volume= 0.292 af, Depth= 5.37"  
Routed to Reach 30R : DP-3

Runoff by SCS TR-20 method, UH=SCS, Weighted-CN, Time Span= 0.00-36.00 hrs, dt= 0.05 hrs  
NRCC 24-hr D 100-Year Rainfall=8.36"

| Area (ac) | CN | Description                   |
|-----------|----|-------------------------------|
| 0.234     | 39 | >75% Grass cover, Good, HSG A |
| 0.400     | 98 | Paved parking, HSG A          |
| 0.020     | 30 | Woods, Good, HSG A            |
| 0.654     | 75 | Weighted Average              |
| 0.254     |    | 38.83% Pervious Area          |
| 0.400     |    | 61.17% Impervious Area        |

| Tc (min) | Length (feet) | Slope (ft/ft) | Velocity (ft/sec) | Capacity (cfs) | Description       |
|----------|---------------|---------------|-------------------|----------------|-------------------|
| 6.0      |               |               |                   |                | Direct Entry, MIN |

**Subcatchment 30S: EDA-3**

Hydrograph

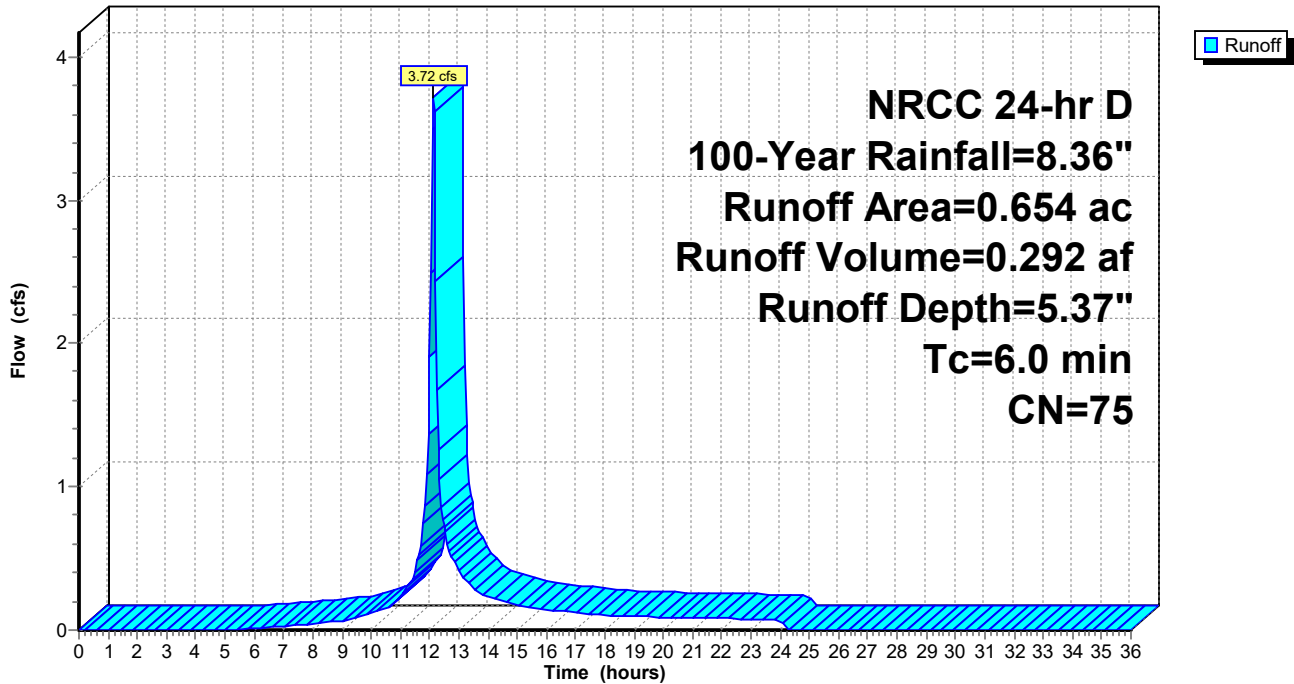

**206327HC002A**

Prepared by Beals & Thomas Inc

HydroCAD® 10.20-3c s/n 04493 © 2023 HydroCAD Software Solutions LLC

2063.27 Pre-Development  
NRCC 24-hr D 100-Year Rainfall=8.36"

Printed 8/22/2023

Page 14

**Summary for Subcatchment 40S: EDA-4**

Runoff = 1.79 cfs @ 12.13 hrs, Volume= 0.140 af, Depth= 4.89"  
Routed to Reach 40R : DP-4

Runoff by SCS TR-20 method, UH=SCS, Weighted-CN, Time Span= 0.00-36.00 hrs, dt= 0.05 hrs  
NRCC 24-hr D 100-Year Rainfall=8.36"

| Area (ac) | CN | Description                   |
|-----------|----|-------------------------------|
| 0.153     | 39 | >75% Grass cover, Good, HSG A |
| 0.188     | 98 | Paved parking, HSG A          |
| 0.001     | 30 | Woods, Good, HSG A            |
| 0.342     | 71 | Weighted Average              |
| 0.154     |    | 44.97% Pervious Area          |
| 0.188     |    | 55.03% Impervious Area        |

| Tc (min) | Length (feet) | Slope (ft/ft) | Velocity (ft/sec) | Capacity (cfs) | Description       |
|----------|---------------|---------------|-------------------|----------------|-------------------|
| 6.0      |               |               |                   |                | Direct Entry, MIN |

**Subcatchment 40S: EDA-4**

Hydrograph

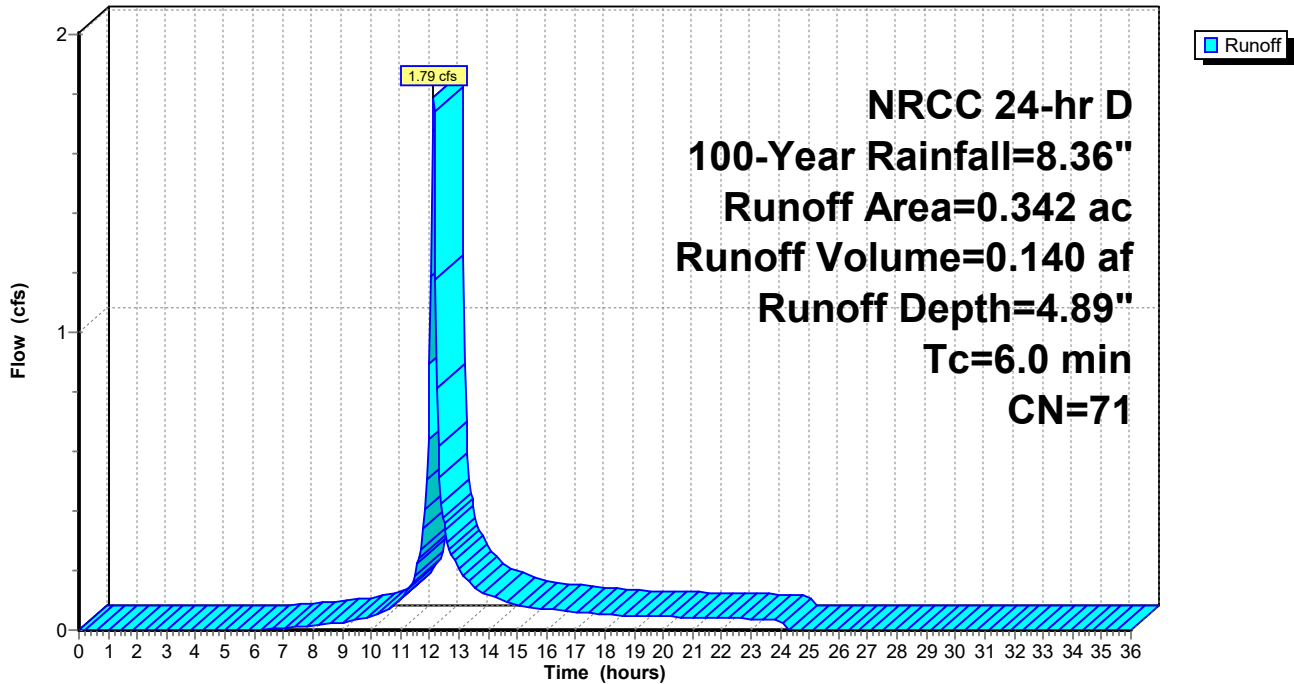

### Summary for Reach 10R: DP-1

[40] Hint: Not Described (Outflow=Inflow)

Inflow Area = 6.760 ac, 48.62% Impervious, Inflow Depth = 4.42" for 100-Year event  
Inflow = 23.52 cfs @ 12.24 hrs, Volume= 2.491 af  
Outflow = 23.52 cfs @ 12.24 hrs, Volume= 2.491 af, Atten= 0%, Lag= 0.0 min  
Routed to Pond 10P : E-POND

Routing by Stor-Ind+Trans method, Time Span= 0.00-36.00 hrs, dt= 0.05 hrs

### Reach 10R: DP-1

Hydrograph

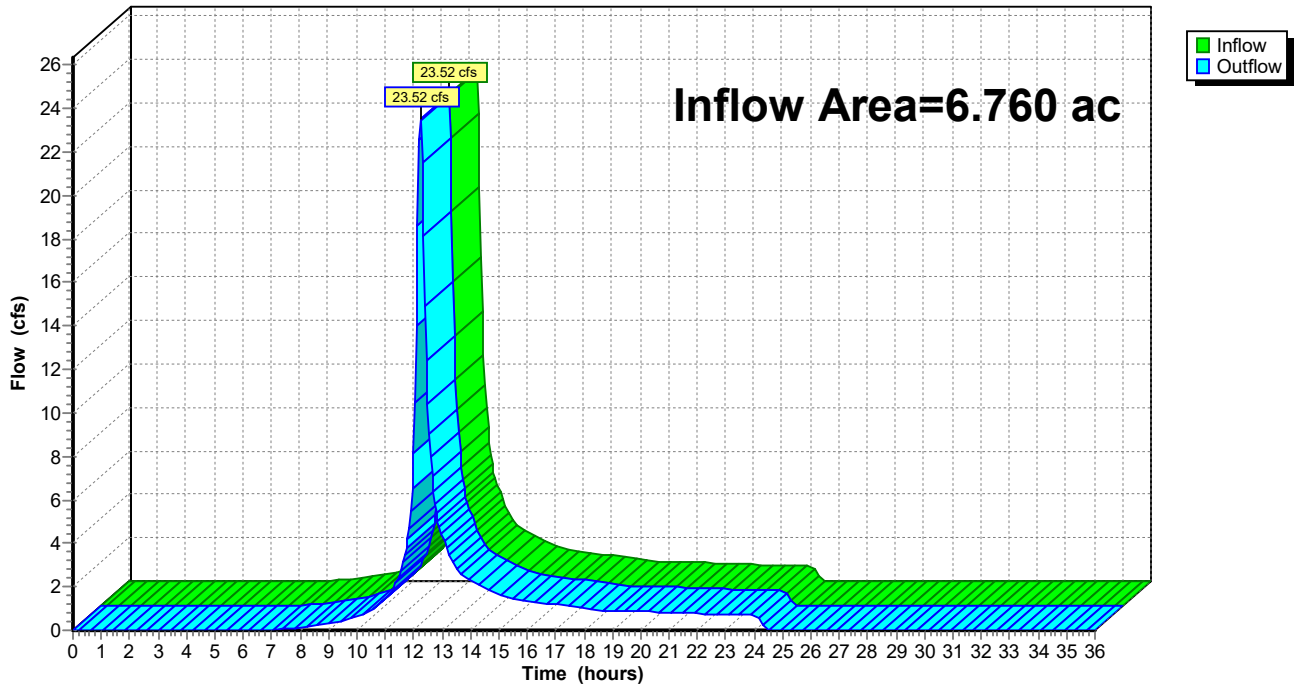

### Summary for Reach 20R: DP-2

[40] Hint: Not Described (Outflow=Inflow)

Inflow Area = 6.955 ac, 47.26% Impervious, Inflow Depth > 0.77" for 100-Year event  
Inflow = 0.23 cfs @ 23.99 hrs, Volume= 0.447 af  
Outflow = 0.23 cfs @ 23.99 hrs, Volume= 0.447 af, Atten= 0%, Lag= 0.0 min  
Routed to Reach 50R : DP-5

Routing by Stor-Ind+Trans method, Time Span= 0.00-36.00 hrs, dt= 0.05 hrs

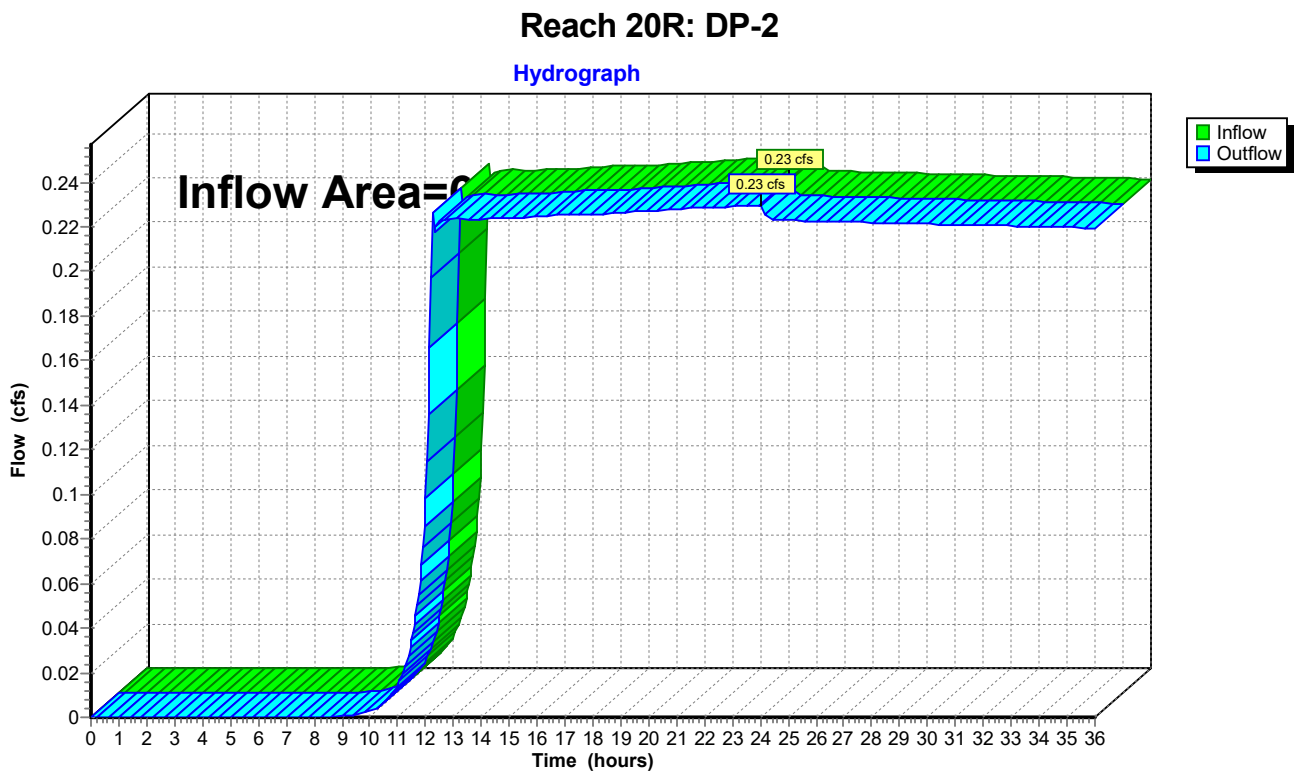

### Summary for Reach 30R: DP-3

[40] Hint: Not Described (Outflow=Inflow)

Inflow Area = 0.654 ac, 61.17% Impervious, Inflow Depth = 5.37" for 100-Year event  
Inflow = 3.72 cfs @ 12.13 hrs, Volume= 0.292 af  
Outflow = 3.72 cfs @ 12.13 hrs, Volume= 0.292 af, Atten= 0%, Lag= 0.0 min  
Routed to Reach 50R : DP-5

Routing by Stor-Ind+Trans method, Time Span= 0.00-36.00 hrs, dt= 0.05 hrs

### Reach 30R: DP-3

Hydrograph

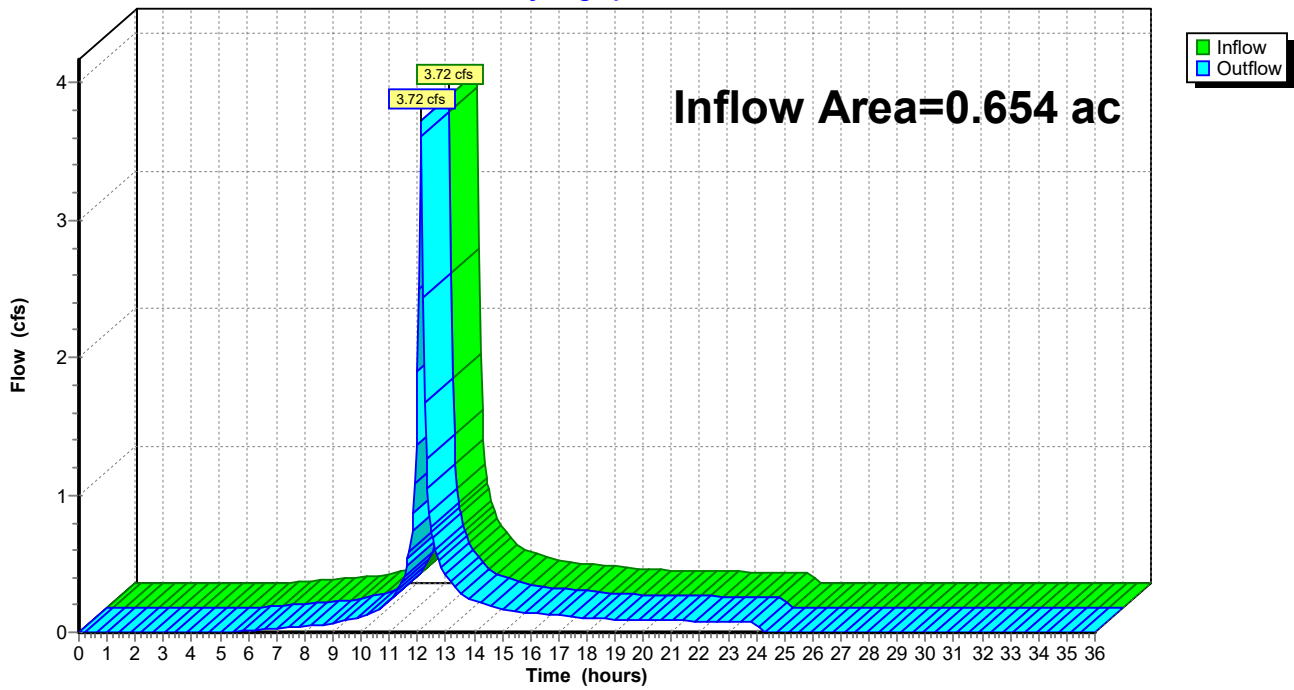

### Summary for Reach 40R: DP-4

[40] Hint: Not Described (Outflow=Inflow)

Inflow Area = 0.342 ac, 55.03% Impervious, Inflow Depth = 4.89" for 100-Year event  
Inflow = 1.79 cfs @ 12.13 hrs, Volume= 0.140 af  
Outflow = 1.79 cfs @ 12.13 hrs, Volume= 0.140 af, Atten= 0%, Lag= 0.0 min  
Routed to Reach 60R : DP-6

Routing by Stor-Ind+Trans method, Time Span= 0.00-36.00 hrs, dt= 0.05 hrs

### Reach 40R: DP-4

Hydrograph

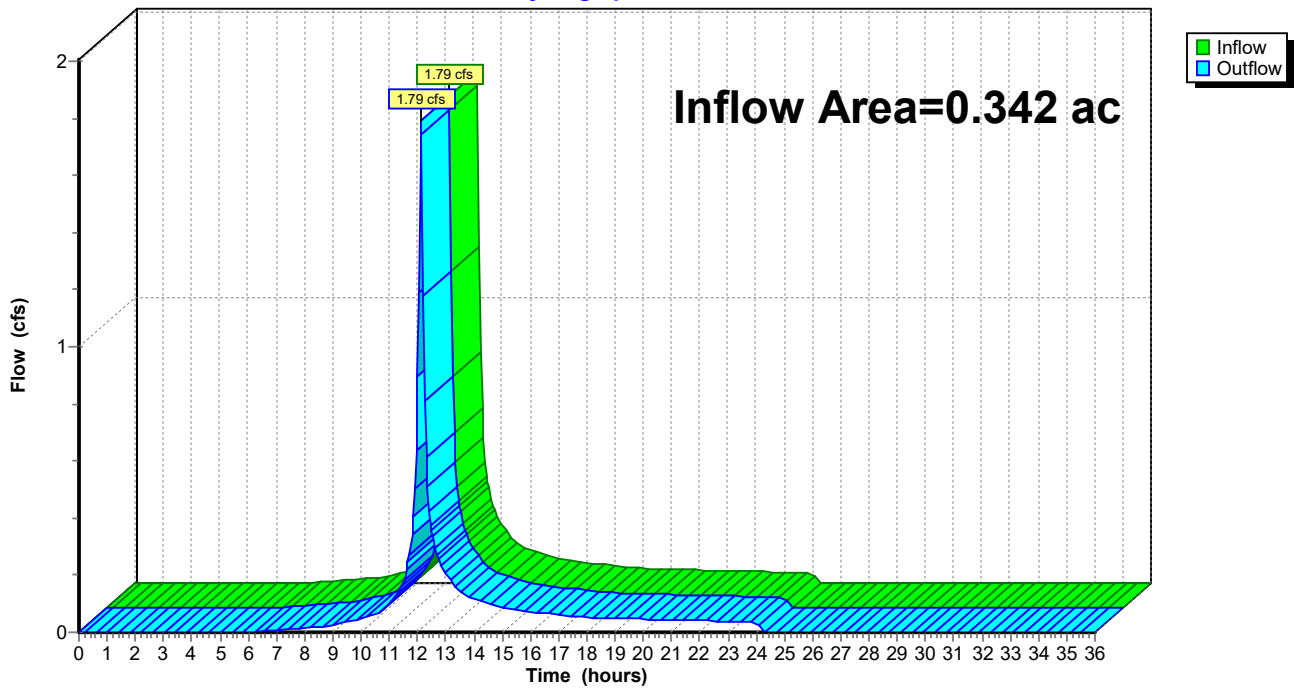

### Summary for Reach 50R: DP-5

[40] Hint: Not Described (Outflow=Inflow)

Inflow Area = 7.609 ac, 48.45% Impervious, Inflow Depth > 1.17" for 100-Year event  
Inflow = 3.87 cfs @ 12.13 hrs, Volume= 0.739 af  
Outflow = 3.87 cfs @ 12.13 hrs, Volume= 0.739 af, Atten= 0%, Lag= 0.0 min  
Routed to Reach 60R : DP-6

Routing by Stor-Ind+Trans method, Time Span= 0.00-36.00 hrs, dt= 0.05 hrs

### Reach 50R: DP-5

Hydrograph

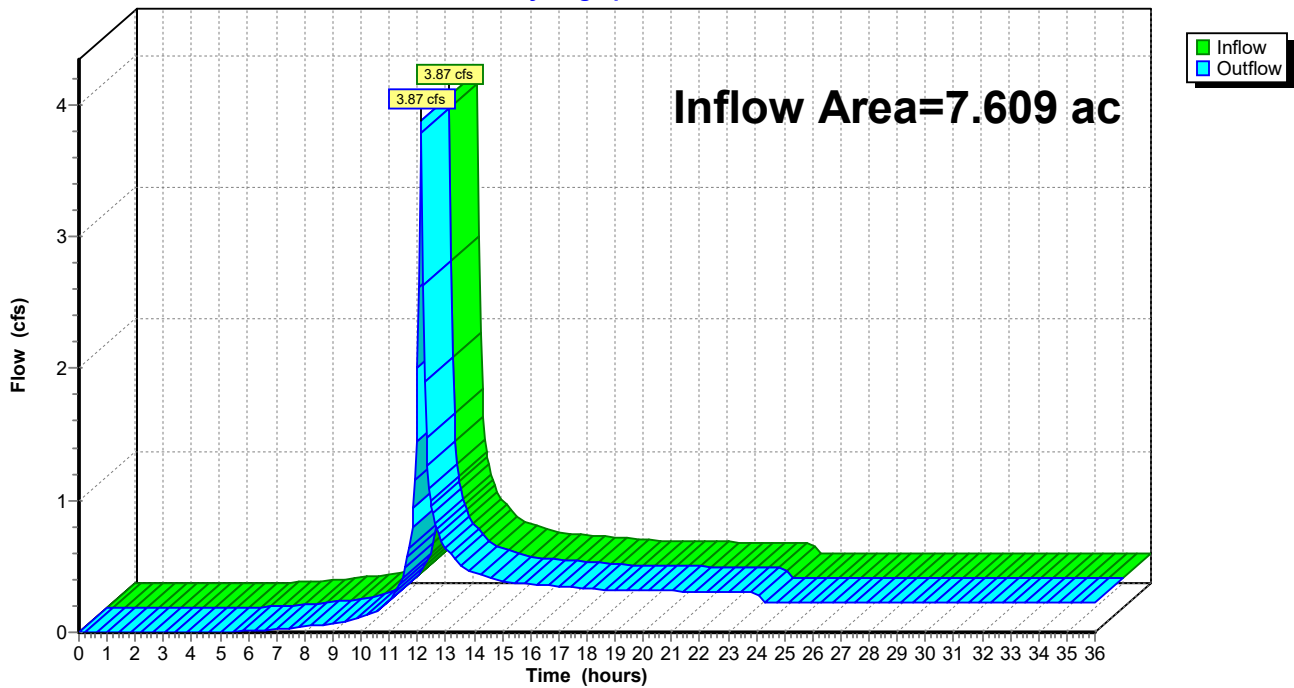

### Summary for Reach 60R: DP-6

[40] Hint: Not Described (Outflow=Inflow)

Inflow Area = 7.951 ac, 48.74% Impervious, Inflow Depth > 1.33" for 100-Year event  
Inflow = 5.67 cfs @ 12.13 hrs, Volume= 0.879 af  
Outflow = 5.67 cfs @ 12.13 hrs, Volume= 0.879 af, Atten= 0%, Lag= 0.0 min

Routing by Stor-Ind+Trans method, Time Span= 0.00-36.00 hrs, dt= 0.05 hrs

### Reach 60R: DP-6

Hydrograph

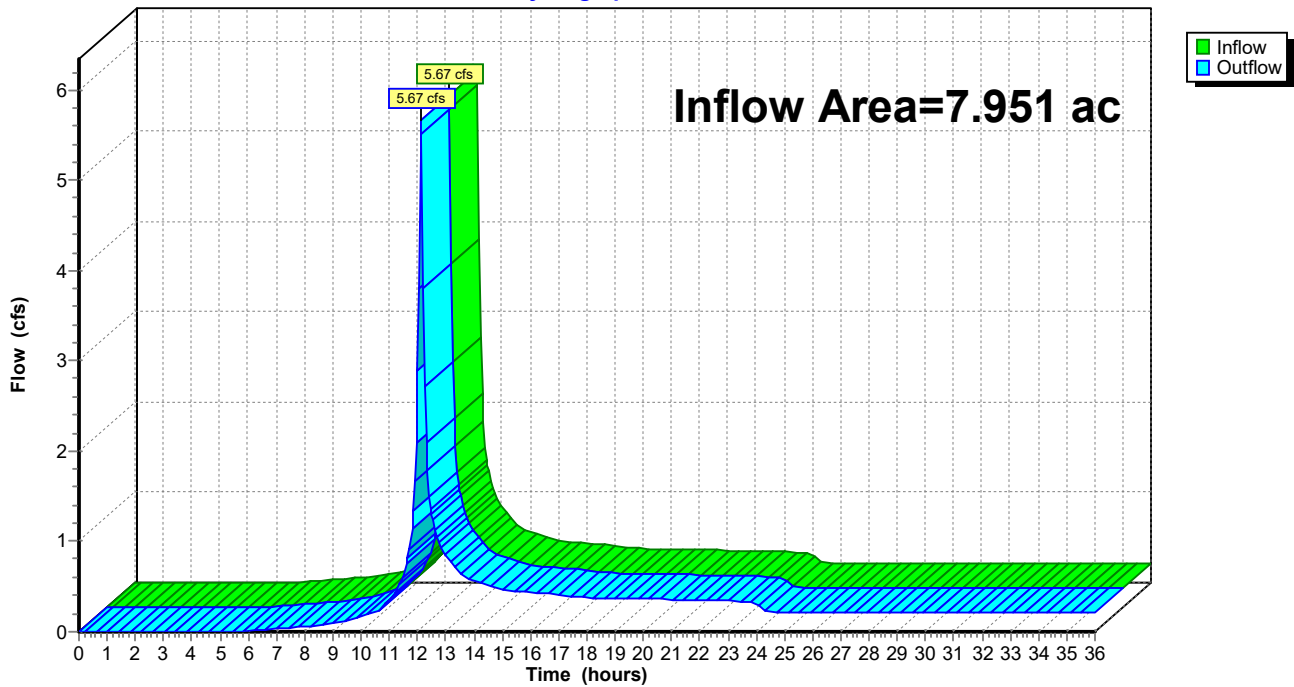

**206327HC002A**

Prepared by Beals & Thomas Inc

HydroCAD® 10.20-3c s/n 04493 © 2023 HydroCAD Software Solutions LLC

2063.27 Pre-Development  
NRCC 24-hr D 100-Year Rainfall=8.36"

Printed 8/22/2023

Page 21

**Summary for Pond 10P: E-POND**

Inflow Area = 6.760 ac, 48.62% Impervious, Inflow Depth = 4.42" for 100-Year event  
Inflow = 23.52 cfs @ 12.24 hrs, Volume= 2.491 af  
Outflow = 0.22 cfs @ 24.27 hrs, Volume= 0.437 af, Atten= 99%, Lag= 721.8 min  
Primary = 0.22 cfs @ 24.27 hrs, Volume= 0.437 af  
Routed to Reach 20R : DP-2

Routing by Stor-Ind method, Time Span= 0.00-36.00 hrs, dt= 0.05 hrs  
Peak Elev= 122.64' @ 24.27 hrs Surf.Area= 1.961 ac Storage= 2.267 af

Plug-Flow detention time= 773.9 min calculated for 0.437 af (18% of inflow)  
Center-of-Mass det. time= 580.0 min ( 1,441.8 - 861.8 )

| Volume              | Invert               | Avail.Storage            | Storage Description  |
|---------------------|----------------------|--------------------------|--|
| #1                  | 121.40'              | 2.981 af                 | <b>Custom Stage Data (Prismatic)</b> Listed below (Recalc) |
| Elevation<br>(feet) | Surf.Area<br>(acres) | Inc.Store<br>(acre-feet) | Cum.Store<br>(acre-feet)                                   |
| 121.40              | 1.720                | 0.000                    | 0.000  |
| 122.00              | 1.800                | 1.056                    | 1.056  |
| 123.00              | 2.050                | 1.925                    | 2.981  |

| Device | Routing | Invert  | Outlet Devices   |
|--------|---------|---------|--|
| #1     | Primary | 121.40' | <b>4.0" Round Culvert</b><br>L= 275.0' CMP, end-section conforming to fill, Ke= 0.500<br>Inlet / Outlet Invert= 121.40' / 118.93' S= 0.0090 '/ Cc= 0.900<br>n= 0.012, Flow Area= 0.09 sf |

**Primary OutFlow** Max=0.22 cfs @ 24.27 hrs HW=122.64' (Free Discharge)  
↑**1=Culvert** (Barrel Controls 0.22 cfs @ 2.56 fps)

### Pond 10P: E-POND

Hydrograph

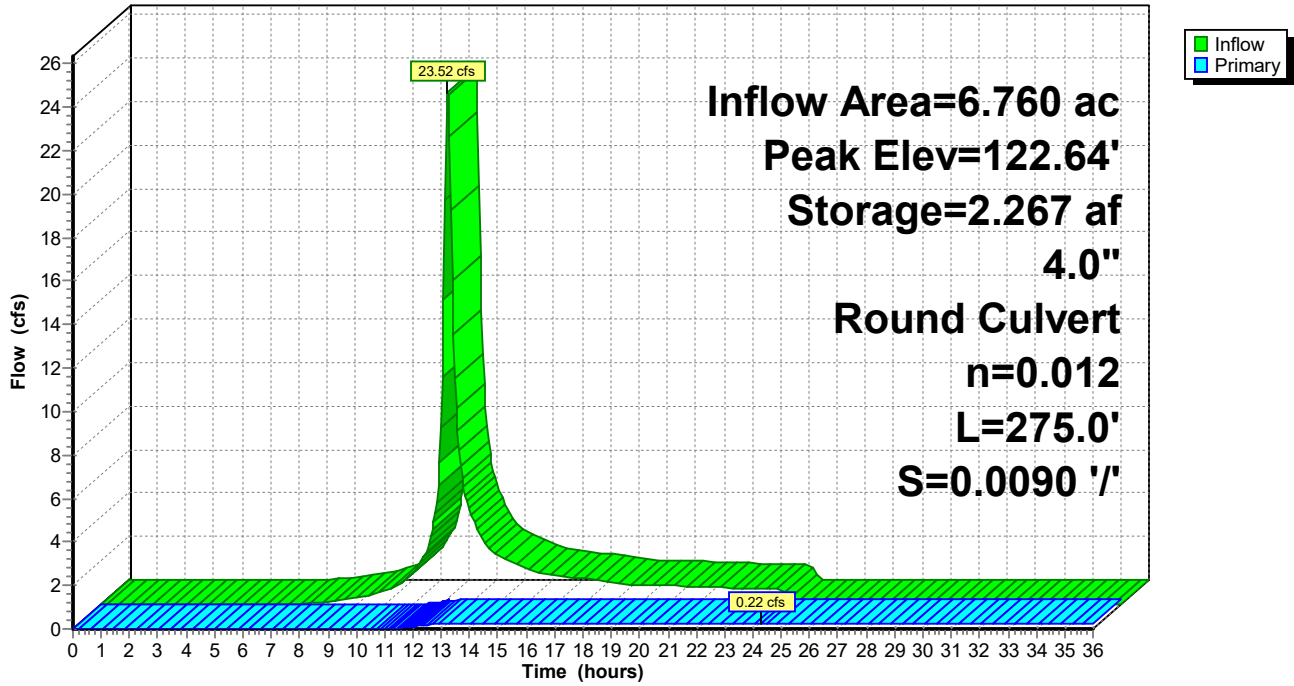

**206327HC002A**

Prepared by Beals &amp; Thomas Inc

HydroCAD® 10.20-3c s/n 04493 © 2023 HydroCAD Software Solutions LLC

2063.27 Pre-Development

NRCC 24-hr D 100-Year Rainfall=8.36"

Printed 8/22/2023

Page 23

**Stage-Area-Storage for Pond 10P: E-POND**

| Elevation<br>(feet) | Surface<br>(acres) | Storage<br>(acre-feet) | Elevation<br>(feet) | Surface<br>(acres) | Storage<br>(acre-feet) |
|---------------------|--------------------|------------------------|---------------------|--------------------|------------------------|
| 121.40              | 1.720              | 0.000                  | 122.42              | 1.905              | 1.834                  |
| 121.42              | 1.723              | 0.034                  | 122.44              | 1.910              | 1.872                  |
| 121.44              | 1.725              | 0.069                  | 122.46              | 1.915              | 1.910                  |
| 121.46              | 1.728              | 0.103                  | 122.48              | 1.920              | 1.949                  |
| 121.48              | 1.731              | 0.138                  | 122.50              | 1.925              | 1.987                  |
| 121.50              | 1.733              | 0.173                  | 122.52              | 1.930              | 2.026                  |
| 121.52              | 1.736              | 0.207                  | 122.54              | 1.935              | 2.064                  |
| 121.54              | 1.739              | 0.242                  | 122.56              | 1.940              | 2.103                  |
| 121.56              | 1.741              | 0.277                  | 122.58              | 1.945              | 2.142                  |
| 121.58              | 1.744              | 0.312                  | 122.60              | 1.950              | 2.181                  |
| 121.60              | 1.747              | 0.347                  | 122.62              | 1.955              | 2.220                  |
| 121.62              | 1.749              | 0.382                  | 122.64              | 1.960              | 2.259                  |
| 121.64              | 1.752              | 0.417                  | 122.66              | 1.965              | 2.298                  |
| 121.66              | 1.755              | 0.452                  | 122.68              | 1.970              | 2.338                  |
| 121.68              | 1.757              | 0.487                  | 122.70              | 1.975              | 2.377                  |
| 121.70              | 1.760              | 0.522                  | 122.72              | 1.980              | 2.417                  |
| 121.72              | 1.763              | 0.557                  | 122.74              | 1.985              | 2.456                  |
| 121.74              | 1.765              | 0.593                  | 122.76              | 1.990              | 2.496                  |
| 121.76              | 1.768              | 0.628                  | 122.78              | 1.995              | 2.536                  |
| 121.78              | 1.771              | 0.663                  | 122.80              | 2.000              | 2.576                  |
| 121.80              | 1.773              | 0.699                  | 122.82              | 2.005              | 2.616                  |
| 121.82              | 1.776              | 0.734                  | 122.84              | 2.010              | 2.656                  |
| 121.84              | 1.779              | 0.770                  | 122.86              | 2.015              | 2.696                  |
| 121.86              | 1.781              | 0.805                  | 122.88              | 2.020              | 2.737                  |
| 121.88              | 1.784              | 0.841                  | 122.90              | 2.025              | 2.777                  |
| 121.90              | 1.787              | 0.877                  | 122.92              | 2.030              | 2.818                  |
| 121.92              | 1.789              | 0.912                  | 122.94              | 2.035              | 2.858                  |
| 121.94              | 1.792              | 0.948                  | 122.96              | 2.040              | 2.899                  |
| 121.96              | 1.795              | 0.984                  | 122.98              | 2.045              | 2.940                  |
| 121.98              | 1.797              | 1.020                  | 123.00              | <b>2.050</b>       | <b>2.981</b>           |
| 122.00              | 1.800              | 1.056                  |                     |                    |                        |
| 122.02              | 1.805              | 1.092                  |                     |                    |                        |
| 122.04              | 1.810              | 1.128                  |                     |                    |                        |
| 122.06              | 1.815              | 1.164                  |                     |                    |                        |
| 122.08              | 1.820              | 1.201                  |                     |                    |                        |
| 122.10              | 1.825              | 1.237                  |                     |                    |                        |
| 122.12              | 1.830              | 1.274                  |                     |                    |                        |
| 122.14              | 1.835              | 1.310                  |                     |                    |                        |
| 122.16              | 1.840              | 1.347                  |                     |                    |                        |
| 122.18              | 1.845              | 1.384                  |                     |                    |                        |
| 122.20              | 1.850              | 1.421                  |                     |                    |                        |
| 122.22              | 1.855              | 1.458                  |                     |                    |                        |
| 122.24              | 1.860              | 1.495                  |                     |                    |                        |
| 122.26              | 1.865              | 1.532                  |                     |                    |                        |
| 122.28              | 1.870              | 1.570                  |                     |                    |                        |
| 122.30              | 1.875              | 1.607                  |                     |                    |                        |
| 122.32              | 1.880              | 1.645                  |                     |                    |                        |
| 122.34              | 1.885              | 1.682                  |                     |                    |                        |
| 122.36              | 1.890              | 1.720                  |                     |                    |                        |
| 122.38              | 1.895              | 1.758                  |                     |                    |                        |
| 122.40              | 1.900              | 1.796                  |                     |                    |                        |

**Attachment 3**  
**Post-Development Hydrologic Analysis**

---

## 2063.27 Post-Development Hydrology Calculation Summary

### Objective

To determine the post-development peak rates of runoff and total runoff volumes to the respective design points associated with the 2, 10, 25 & 100-year storm events.

### Conclusion

| Storm Event | 2-Year Runoff |              | 10-Year Runoff |              | 25-Year Runoff |              | 100-Year Runoff |              |
|-------------|---------------|--------------|----------------|--------------|----------------|--------------|-----------------|--------------|
|             | Peak Rate     | Total Volume | Peak Rate      | Total Volume | Peak Rate      | Total Volume | Peak Rate       | Total Volume |
| DP-1        | 3.00 cfs      | 0.322 af     | 7.03 cfs       | 0.726 af     | 10.66 cfs      | 1.139 af     | 20.54 cfs       | 2.133 af     |
| DP-2        | 0.23 cfs      | 0.222 af     | 0.46 cfs       | 0.529 af     | 1.04 cfs       | 0.716 af     | 1.81 cfs        | 0.950 af     |
| DP-3        | 0.38 cfs      | 0.060 af     | 0.98 cfs       | 0.110 af     | 1.41 cfs       | 0.152 af     | 2.24 cfs        | 0.243 af     |
| DP-4        | 0.13 cfs      | 0.010 af     | 0.21 cfs       | 0.017 af     | 0.27 cfs       | 0.022 af     | 0.39 cfs        | 0.034 af     |
| DP-5        | 0.58 cfs      | 0.282 af     | 1.26 cfs       | 0.640 af     | 1.90 cfs       | 0.869 af     | 3.68 cfs        | 1.193 af     |
| DP-6        | 0.64 cfs      | 0.292 af     | 1.40 cfs       | 0.657 af     | 2.03 cfs       | 0.891 af     | 3.95 cfs        | 1.226 af     |

### Calculation Methods

1. Runoff curve numbers (CN) and times-of-concentration (Tc) are based on TR-55 methodology.
2. Peak rates of runoff and total runoff volumes were computed with HydroCAD (version 10.20-3c).
3. Subcatchment areas were imported into HydroCAD from AutoCAD Civil 3D.

### Assumptions

1. A minimum time-of-concentration (Tc) of 6.0 minutes was used, where applicable.
2. Storm events are NRCC 24-hr D rainfall distribution for Concord, Massachusetts.
3. Surface cover types and watershed boundaries were estimated based on B+T topographic base information.
4. For areas with dual Hydrologic Soil Group (HSG) classifications, wetlands were considered HSG D.
5. Soils mapped as "Udorthents" and/or "Urban Land" were considered HSG A soils, given the HSG of adjacent mapped soils.
6. Design Points are as follows:
  - o Interim Design Points
    - DP-1 - To Existing Pond
    - DP-2 - West to Conservation Restriction
    - DP-3 - Northwest to rear of #300 Baker Avenue
  - o Primary Design Points
    - DP-4 - To Existing Stormwater Infrastructure East of #300 Baker Avenue
    - DP-5 - To Bordering Vegetative Wetlands to the West
    - DP-6 - To Assabet River (Confluence of DP-4 & DP-5)
7. Proposed interior landscape islands considered impervious.

#### Corporate Office

144 Turnpike Road  
Southborough, MA 01772

[bealsandthomas.com](http://bealsandthomas.com) T 508.366.0560 F 508.366.4391

#### Regional Office

32 Court Street  
Plymouth, MA 02360

8. Several assumptions were made relative to the proposed subsurface stormwater management best management practice designs, as follows:
  - o Consistent with the HSG A mapping, Subsurface Stormwater Management System #1 was modelled with an exfiltration rate of 2.41 inches per hour.
  - o System #1 is assumed to be “dry” at the beginning of a storm event.
  - o Exfiltration was not modelled (during the storm event) at Subsurface Stormwater Management Systems #2 & #3 due to the proposed bottom elevation.
  - o Conservatively, Systems #2 & #3 were modelled with water starting at the lowest outlet invert elevation at the beginning of a storm event.
9. Tailwater effects have not been analyzed at this time.
10. Proposed floodplain compensatory storage chambers were not modelled for peak-rate attenuation.

### Sources of Data/ Equations

1. Proposed Conditions Watershed Map (dated 8/22/2023) prepared by Beals and Thomas, Inc. (206323P123A-002).
2. Topographic AutoCAD base file 206326B017C generated by Beals and Thomas, Inc.
3. Post-development HydroCAD file 206327HC003A generated by Beals and Thomas, Inc.
4. Existing pond model from HydroCAD file 206317HC001A (Pond P-7: Pond 7) included in the Proposed Hotel Development Stormwater Management Report (206317RP001B) prepared by Beals and Thomas, Inc. dated 9/5/2014.
5. TR-55 Urban Hydrology for Small Watersheds, SCS, 1986.
6. Storm event rainfall from HydroCAD 10.20-3c.
7. Hydrologic Soil Groups per MassMapper GIS data layers and USDA NRCS Web Soil Survey (both downloaded August 5, 2023).
8. Massachusetts Department of Environmental Protection Stormwater Handbook dated February 2008.

### List of Attachments

1. NOVO Riverside Commons Proposed Conditions Watershed Map (Figure 2)
2. Post-Development Hydrologic Calculations.

| REV | CALC. BY | DATE | CHECKED BY | DATE | APPROVED BY | DATE |
|-----|----------|------|------------|------|-------------|------|
| 0   |          |      |            |      |             |      |
|     |          |      |            |      |             |      |
|     |          |      |            |      |             |      |

206327CS003A

#### Corporate Office

144 Turnpike Road  
 Southborough, MA 01772

[bealsandthomas.com](http://bealsandthomas.com) T 508.366.0560 F 508.366.4391

#### Regional Office

32 Court Street  
 Plymouth, MA 02360

## Attachments

---

# NOVO Riverside Commons

Concord, Massachusetts

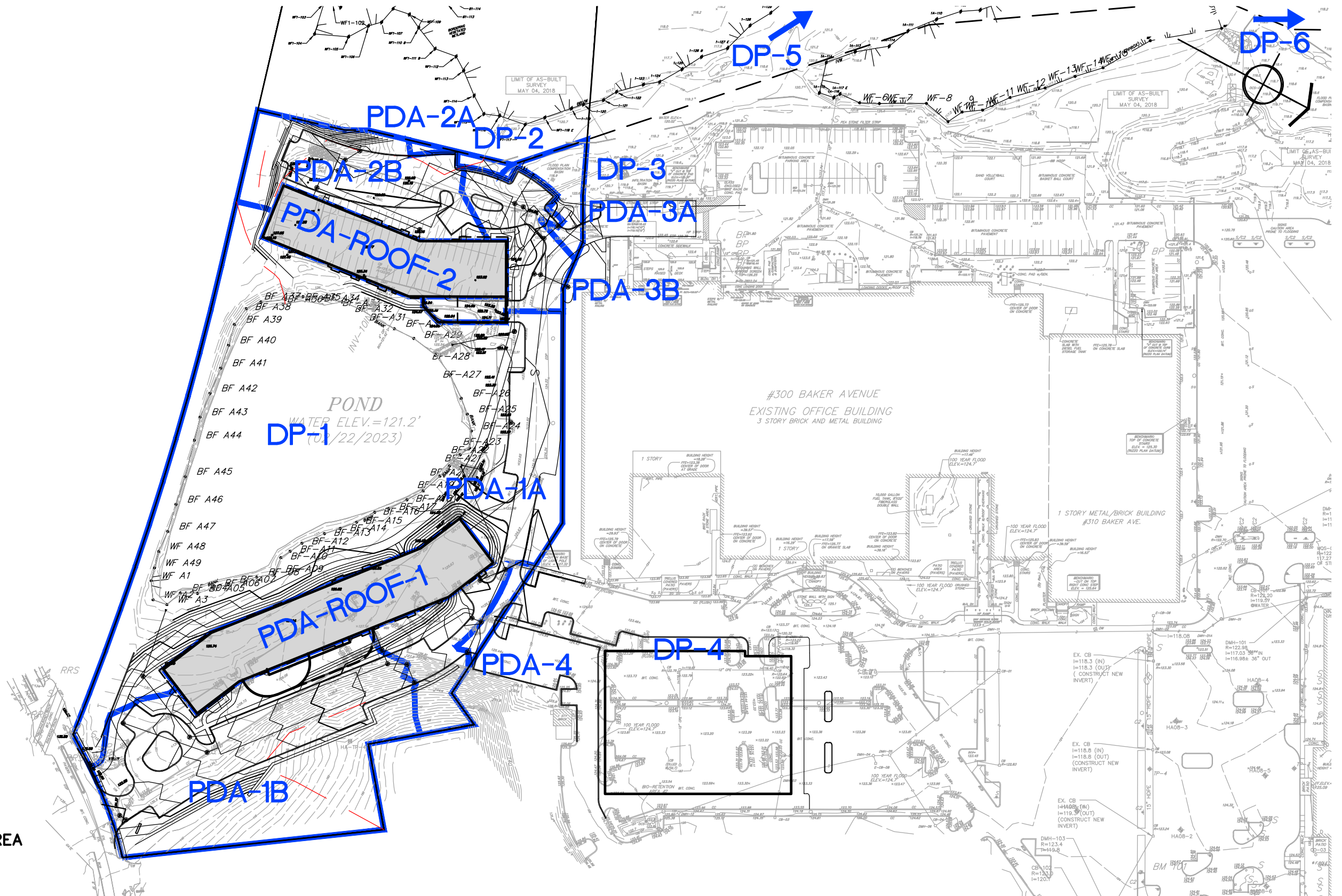

— DRAINAGE AREA  
- - - Tc PATH

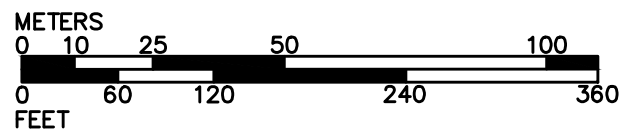

B+T Drawing No. 206327P123A-002 Date: 8/22/2023 Scale: 1" = 120'

**Proposed Conditions**  
Watershed Map

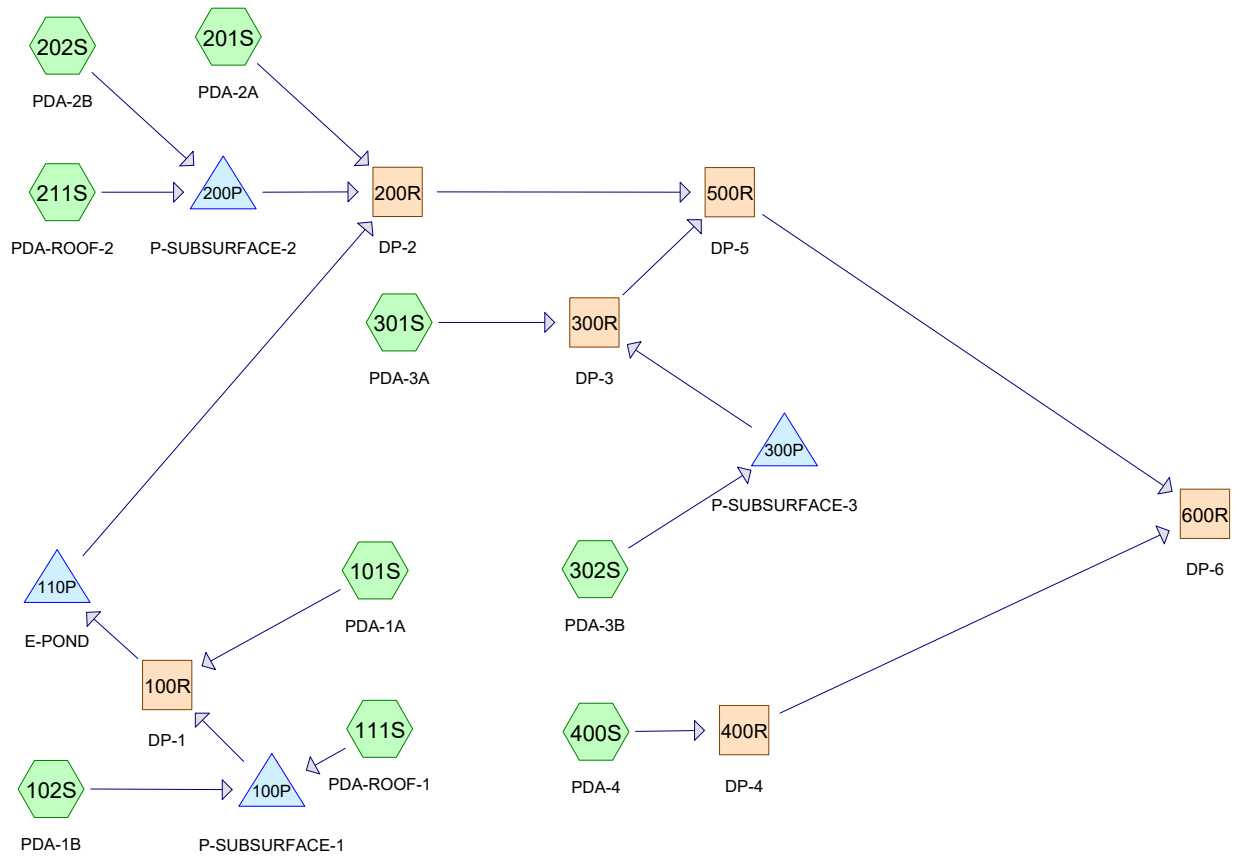

**POST-DEVELOPMENT**

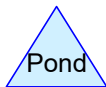
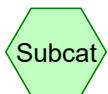

**Routing Diagram for 206327HC003A**  
 Prepared by Beals & Thomas Inc, Printed 8/22/2023  
 HydroCAD® 10.20-3c s/n 04493 © 2023 HydroCAD Software Solutions LLC

**206327HC003A**

Prepared by Beals &amp; Thomas Inc

Printed 8/22/2023

HydroCAD® 10.20-3c s/n 04493 © 2023 HydroCAD Software Solutions LLC

Page 2

**Rainfall Events Listing (selected events)**

| Event# | Event Name | Storm Type | Curve | Mode    | Duration (hours) | B/B | Depth (inches) | AMC |
|--------|------------|------------|-------|---------|------------------|-----|----------------|-----|
| 1      | 2-Year     | NRCC 24-hr | D     | Default | 24.00            | 1   | 3.09           | 2   |
| 2      | 10-Year    | NRCC 24-hr | D     | Default | 24.00            | 1   | 4.65           | 2   |
| 3      | 25-Year    | NRCC 24-hr | D     | Default | 24.00            | 1   | 5.87           | 2   |
| 4      | 100-Year   | NRCC 24-hr | D     | Default | 24.00            | 1   | 8.36           | 2   |

**206327HC003A**

Prepared by Beals &amp; Thomas Inc

Printed 8/22/2023

HydroCAD® 10.20-3c s/n 04493 © 2023 HydroCAD Software Solutions LLC

Page 3

**Area Listing (selected nodes)**

| Area<br>(acres) | CN        | Description<br>(subcatchment-numbers)                                    |
|-----------------|-----------|--|
| 1.749           | 39        | >75% Grass cover, Good, HSG A (101S, 102S, 201S, 202S, 301S, 302S, 400S) |
| 2.101           | 98        | Paved parking, HSG A (101S, 102S, 202S, 301S, 302S, 400S)                |
| 1.177           | 98        | Roofs, HSG A (101S, 102S, 111S, 211S, 302S)                              |
| 1.724           | 98        | Water Surface, HSG D (101S)  |
| 1.068           | 30        | Woods, Good, HSG A (101S, 102S, 201S, 202S, 301S, 302S)                  |
| 0.132           | 77        | Woods, Good, HSG D (101S)  |
| <b>7.951</b>    | <b>76</b> | <b>TOTAL AREA</b>  |

**206327HC003A**

Prepared by Beals &amp; Thomas Inc

Printed 8/22/2023

HydroCAD® 10.20-3c s/n 04493 © 2023 HydroCAD Software Solutions LLC

Page 4

**Soil Listing (selected nodes)**

| Area<br>(acres) | Soil<br>Group | Subcatchment<br>Numbers                              |
|-----------------|---------------|--|
| 6.095           | HSG A         | 101S, 102S, 111S, 201S, 202S, 211S, 301S, 302S, 400S |
| 0.000           | HSG B         |  |
| 0.000           | HSG C         |  |
| 1.856           | HSG D         | 101S   |
| 0.000           | Other         |  |
| <b>7.951</b>    |               | <b>TOTAL AREA</b>                                    |

**206327HC003A**

Prepared by Beals &amp; Thomas Inc

Printed 8/22/2023

HydroCAD® 10.20-3c s/n 04493 © 2023 HydroCAD Software Solutions LLC

Page 5

**Ground Covers (selected nodes)**

| HSG-A<br>(acres) | HSG-B<br>(acres) | HSG-C<br>(acres) | HSG-D<br>(acres) | Other<br>(acres) | Total<br>(acres) | Ground<br>Cover        | Subcatchment<br>Numbers                                    |
|------------------|------------------|------------------|------------------|------------------|------------------|------------------------|--|
| 1.749            | 0.000            | 0.000            | 0.000            | 0.000            | 1.749            | >75% Grass cover, Good | 101S,<br>102S,<br>201S,<br>202S,<br>301S,<br>302S,<br>400S |
| 2.101            | 0.000            | 0.000            | 0.000            | 0.000            | 2.101            | Paved parking          | 101S,<br>102S,<br>202S,<br>301S,<br>302S,<br>400S          |
| 1.177            | 0.000            | 0.000            | 0.000            | 0.000            | 1.177            | Roofs                  | 101S,<br>102S,<br>111S,<br>211S,<br>302S                   |
| 0.000            | 0.000            | 0.000            | 1.724            | 0.000            | 1.724            | Water Surface          | 101S   |
| 1.068            | 0.000            | 0.000            | 0.132            | 0.000            | 1.200            | Woods, Good            | 101S,<br>102S,<br>201S,<br>202S,<br>301S,<br>302S          |
| <b>6.095</b>     | <b>0.000</b>     | <b>0.000</b>     | <b>1.856</b>     | <b>0.000</b>     | <b>7.951</b>     | <b>TOTAL AREA</b>      |  |

**206327HC003A**

Prepared by Beals &amp; Thomas Inc

HydroCAD® 10.20-3c s/n 04493 © 2023 HydroCAD Software Solutions LLC

2063.27 Post-Development  
NRCC 24-hr D 2-Year Rainfall=3.09"

Printed 8/22/2023

Page 6

Time span=0.00-36.00 hrs, dt=0.05 hrs, 721 points  
 Runoff by SCS TR-20 method, UH=SCS, Weighted-CN  
 Reach routing by Stor-Ind+Trans method - Pond routing by Stor-Ind method

|                                      |  |
|--------------------------------------|--|
| <b>Subcatchment 101S: PDA-1A</b>     | Runoff Area=4.233 ac 58.72% Impervious Runoff Depth=0.91"<br>Flow Length=136' Tc=13.6 min CN=73 Runoff=3.00 cfs 0.322 af                       |
| <b>Subcatchment 102S: PDA-1B</b>     | Runoff Area=1.523 ac 52.30% Impervious Runoff Depth=0.67"<br>Flow Length=303' Tc=8.3 min CN=68 Runoff=0.89 cfs 0.086 af                        |
| <b>Subcatchment 111S: PDA-ROOF-1</b> | Runoff Area=0.585 ac 100.00% Impervious Runoff Depth=2.86"<br>Tc=6.0 min CN=98 Runoff=1.57 cfs 0.139 af  |
| <b>Subcatchment 201S: PDA-2A</b>     | Runoff Area=0.032 ac 0.00% Impervious Runoff Depth=0.00"<br>Tc=6.0 min CN=32 Runoff=0.00 cfs 0.000 af  |
| <b>Subcatchment 202S: PDA-2B</b>     | Runoff Area=0.600 ac 53.17% Impervious Runoff Depth=0.72"<br>Flow Length=205' Tc=14.1 min CN=69 Runoff=0.31 cfs 0.036 af                       |
| <b>Subcatchment 211S: PDA-ROOF-2</b> | Runoff Area=0.427 ac 100.00% Impervious Runoff Depth=2.86"<br>Tc=6.0 min CN=98 Runoff=1.14 cfs 0.102 af  |
| <b>Subcatchment 301S: PDA-3A</b>     | Runoff Area=0.126 ac 24.17% Impervious Runoff Depth=0.17"<br>Tc=6.0 min CN=53 Runoff=0.00 cfs 0.002 af   |
| <b>Subcatchment 302S: PDA-3B</b>     | Runoff Area=0.370 ac 83.79% Impervious Runoff Depth=1.90"<br>Tc=6.0 min CN=88 Runoff=0.75 cfs 0.059 af   |
| <b>Subcatchment 400S: PDA-4</b>      | Runoff Area=0.056 ac 88.26% Impervious Runoff Depth=2.16"<br>Tc=6.0 min CN=91 Runoff=0.13 cfs 0.010 af   |
| <b>Reach 100R: DP-1</b>              | Inflow=3.00 cfs 0.322 af<br>Outflow=3.00 cfs 0.322 af  |
| <b>Reach 200R: DP-2</b>              | Inflow=0.23 cfs 0.222 af<br>Outflow=0.23 cfs 0.222 af  |
| <b>Reach 300R: DP-3</b>              | Inflow=0.38 cfs 0.060 af<br>Outflow=0.38 cfs 0.060 af  |
| <b>Reach 400R: DP-4</b>              | Inflow=0.13 cfs 0.010 af<br>Outflow=0.13 cfs 0.010 af  |
| <b>Reach 500R: DP-5</b>              | Inflow=0.58 cfs 0.282 af<br>Outflow=0.58 cfs 0.282 af  |
| <b>Reach 600R: DP-6</b>              | Inflow=0.64 cfs 0.292 af<br>Outflow=0.64 cfs 0.292 af  |
| <b>Pond 100P: P-SUBSURFACE-1</b>     | Peak Elev=124.46' Storage=0.052 af Inflow=2.41 cfs 0.225 af<br>Discarded=0.36 cfs 0.225 af Primary=0.00 cfs 0.000 af Outflow=0.36 cfs 0.225 af |

**206327HC003A**

Prepared by Beals & Thomas Inc

HydroCAD® 10.20-3c s/n 04493 © 2023 HydroCAD Software Solutions LLC

2063.27 Post-Development  
NRCC 24-hr D 2-Year Rainfall=3.09"

Printed 8/22/2023

Page 7

**Pond 110P: E-POND**

Peak Elev=121.56' Storage=0.284 af Inflow=3.00 cfs 0.322 af  
4.0" Round Culvert n=0.012 L=275.0' S=0.0090 '/ Outflow=0.06 cfs 0.084 af

**Pond 200P: P-SUBSURFACE-2**

Peak Elev=121.28' Storage=0.069 af Inflow=1.35 cfs 0.138 af  
Outflow=0.22 cfs 0.137 af

**Pond 300P: P-SUBSURFACE-3**

Peak Elev=121.22' Storage=0.009 af Inflow=0.75 cfs 0.059 af  
Outflow=0.38 cfs 0.059 af

**Total Runoff Area = 7.951 ac Runoff Volume = 0.755 af Average Runoff Depth = 1.14"**  
**37.08% Pervious = 2.948 ac 62.92% Impervious = 5.003 ac**

**206327HC003A**

Prepared by Beals &amp; Thomas Inc

HydroCAD® 10.20-3c s/n 04493 © 2023 HydroCAD Software Solutions LLC

2063.27 Post-Development  
NRCC 24-hr D 10-Year Rainfall=4.65"

Printed 8/22/2023

Page 8

Time span=0.00-36.00 hrs, dt=0.05 hrs, 721 points  
 Runoff by SCS TR-20 method, UH=SCS, Weighted-CN  
 Reach routing by Stor-Ind+Trans method - Pond routing by Stor-Ind method

|                                      |  |
|--------------------------------------|--|
| <b>Subcatchment 101S: PDA-1A</b>     | Runoff Area=4.233 ac 58.72% Impervious Runoff Depth=2.01"<br>Flow Length=136' Tc=13.6 min CN=73 Runoff=7.03 cfs 0.709 af                       |
| <b>Subcatchment 102S: PDA-1B</b>     | Runoff Area=1.523 ac 52.30% Impervious Runoff Depth=1.63"<br>Flow Length=303' Tc=8.3 min CN=68 Runoff=2.43 cfs 0.208 af                        |
| <b>Subcatchment 111S: PDA-ROOF-1</b> | Runoff Area=0.585 ac 100.00% Impervious Runoff Depth=4.41"<br>Tc=6.0 min CN=98 Runoff=2.38 cfs 0.215 af  |
| <b>Subcatchment 201S: PDA-2A</b>     | Runoff Area=0.032 ac 0.00% Impervious Runoff Depth=0.01"<br>Tc=6.0 min CN=32 Runoff=0.00 cfs 0.000 af  |
| <b>Subcatchment 202S: PDA-2B</b>     | Runoff Area=0.600 ac 53.17% Impervious Runoff Depth=1.71"<br>Flow Length=205' Tc=14.1 min CN=69 Runoff=0.82 cfs 0.085 af                       |
| <b>Subcatchment 211S: PDA-ROOF-2</b> | Runoff Area=0.427 ac 100.00% Impervious Runoff Depth=4.41"<br>Tc=6.0 min CN=98 Runoff=1.74 cfs 0.157 af  |
| <b>Subcatchment 301S: PDA-3A</b>     | Runoff Area=0.126 ac 24.17% Impervious Runoff Depth=0.70"<br>Tc=6.0 min CN=53 Runoff=0.07 cfs 0.007 af   |
| <b>Subcatchment 302S: PDA-3B</b>     | Runoff Area=0.370 ac 83.79% Impervious Runoff Depth=3.34"<br>Tc=6.0 min CN=88 Runoff=1.28 cfs 0.103 af   |
| <b>Subcatchment 400S: PDA-4</b>      | Runoff Area=0.056 ac 88.26% Impervious Runoff Depth=3.64"<br>Tc=6.0 min CN=91 Runoff=0.21 cfs 0.017 af   |
| <b>Reach 100R: DP-1</b>              | Inflow=7.03 cfs 0.726 af<br>Outflow=7.03 cfs 0.726 af  |
| <b>Reach 200R: DP-2</b>              | Inflow=0.46 cfs 0.529 af<br>Outflow=0.46 cfs 0.529 af  |
| <b>Reach 300R: DP-3</b>              | Inflow=0.98 cfs 0.110 af<br>Outflow=0.98 cfs 0.110 af  |
| <b>Reach 400R: DP-4</b>              | Inflow=0.21 cfs 0.017 af<br>Outflow=0.21 cfs 0.017 af  |
| <b>Reach 500R: DP-5</b>              | Inflow=1.26 cfs 0.640 af<br>Outflow=1.26 cfs 0.640 af  |
| <b>Reach 600R: DP-6</b>              | Inflow=1.40 cfs 0.657 af<br>Outflow=1.40 cfs 0.657 af  |
| <b>Pond 100P: P-SUBSURFACE-1</b>     | Peak Elev=125.17' Storage=0.131 af Inflow=4.73 cfs 0.423 af<br>Discarded=0.45 cfs 0.406 af Primary=0.10 cfs 0.017 af Outflow=0.55 cfs 0.423 af |

**206327HC003A**

Prepared by Beals & Thomas Inc

HydroCAD® 10.20-3c s/n 04493 © 2023 HydroCAD Software Solutions LLC

2063.27 Post-Development  
NRCC 24-hr D 10-Year Rainfall=4.65"

Printed 8/22/2023

Page 9

**Pond 110P: E-POND**

Peak Elev=121.73' Storage=0.580 af Inflow=7.03 cfs 0.726 af  
4.0" Round Culvert n=0.012 L=275.0' S=0.0090 '/ Outflow=0.17 cfs 0.288 af

**Pond 200P: P-SUBSURFACE-2**

Peak Elev=122.15' Storage=0.110 af Inflow=2.34 cfs 0.242 af  
Outflow=0.38 cfs 0.242 af

**Pond 300P: P-SUBSURFACE-3**

Peak Elev=121.85' Storage=0.014 af Inflow=1.28 cfs 0.103 af  
Outflow=0.93 cfs 0.103 af

**Total Runoff Area = 7.951 ac Runoff Volume = 1.501 af Average Runoff Depth = 2.27"**  
**37.08% Pervious = 2.948 ac 62.92% Impervious = 5.003 ac**

**206327HC003A**

Prepared by Beals & Thomas Inc

HydroCAD® 10.20-3c s/n 04493 © 2023 HydroCAD Software Solutions LLC

2063.27 Post-Development  
NRCC 24-hr D 25-Year Rainfall=5.87"

Printed 8/22/2023

Page 10

Time span=0.00-36.00 hrs, dt=0.05 hrs, 721 points  
Runoff by SCS TR-20 method, UH=SCS, Weighted-CN  
Reach routing by Stor-Ind+Trans method - Pond routing by Stor-Ind method

|                                      |  |
|--------------------------------------|--|
| <b>Subcatchment 101S: PDA-1A</b>     | Runoff Area=4.233 ac 58.72% Impervious Runoff Depth=2.98"<br>Flow Length=136' Tc=13.6 min CN=73 Runoff=10.52 cfs 1.052 af                      |
| <b>Subcatchment 102S: PDA-1B</b>     | Runoff Area=1.523 ac 52.30% Impervious Runoff Depth=2.52"<br>Flow Length=303' Tc=8.3 min CN=68 Runoff=3.83 cfs 0.320 af                        |
| <b>Subcatchment 111S: PDA-ROOF-1</b> | Runoff Area=0.585 ac 100.00% Impervious Runoff Depth=5.63"<br>Tc=6.0 min CN=98 Runoff=3.01 cfs 0.275 af  |
| <b>Subcatchment 201S: PDA-2A</b>     | Runoff Area=0.032 ac 0.00% Impervious Runoff Depth=0.11"<br>Tc=6.0 min CN=32 Runoff=0.00 cfs 0.000 af  |
| <b>Subcatchment 202S: PDA-2B</b>     | Runoff Area=0.600 ac 53.17% Impervious Runoff Depth=2.61"<br>Flow Length=205' Tc=14.1 min CN=69 Runoff=1.27 cfs 0.131 af                       |
| <b>Subcatchment 211S: PDA-ROOF-2</b> | Runoff Area=0.427 ac 100.00% Impervious Runoff Depth=5.63"<br>Tc=6.0 min CN=98 Runoff=2.20 cfs 0.200 af  |
| <b>Subcatchment 301S: PDA-3A</b>     | Runoff Area=0.126 ac 24.17% Impervious Runoff Depth=1.29"<br>Tc=6.0 min CN=53 Runoff=0.16 cfs 0.014 af   |
| <b>Subcatchment 302S: PDA-3B</b>     | Runoff Area=0.370 ac 83.79% Impervious Runoff Depth=4.50"<br>Tc=6.0 min CN=88 Runoff=1.70 cfs 0.139 af   |
| <b>Subcatchment 400S: PDA-4</b>      | Runoff Area=0.056 ac 88.26% Impervious Runoff Depth=4.83"<br>Tc=6.0 min CN=91 Runoff=0.27 cfs 0.022 af   |
| <b>Reach 100R: DP-1</b>              | Inflow=10.66 cfs 1.139 af<br>Outflow=10.66 cfs 1.139 af  |
| <b>Reach 200R: DP-2</b>              | Inflow=1.04 cfs 0.716 af<br>Outflow=1.04 cfs 0.716 af  |
| <b>Reach 300R: DP-3</b>              | Inflow=1.41 cfs 0.152 af<br>Outflow=1.41 cfs 0.152 af  |
| <b>Reach 400R: DP-4</b>              | Inflow=0.27 cfs 0.022 af<br>Outflow=0.27 cfs 0.022 af  |
| <b>Reach 500R: DP-5</b>              | Inflow=1.90 cfs 0.869 af<br>Outflow=1.90 cfs 0.869 af  |
| <b>Reach 600R: DP-6</b>              | Inflow=2.03 cfs 0.891 af<br>Outflow=2.03 cfs 0.891 af  |
| <b>Pond 100P: P-SUBSURFACE-1</b>     | Peak Elev=125.67' Storage=0.188 af Inflow=6.74 cfs 0.595 af<br>Discarded=0.51 cfs 0.507 af Primary=0.52 cfs 0.087 af Outflow=1.02 cfs 0.595 af |

**206327HC003A**

Prepared by Beals & Thomas Inc

HydroCAD® 10.20-3c s/n 04493 © 2023 HydroCAD Software Solutions LLC

2063.27 Post-Development  
NRCC 24-hr D 25-Year Rainfall=5.87"

Printed 8/22/2023

Page 11

**Pond 110P: E-POND**

Peak Elev=121.94' Storage=0.945 af Inflow=10.66 cfs 1.139 af  
4.0" Round Culvert n=0.012 L=275.0' S=0.0090 ' / Outflow=0.21 cfs 0.386 af

**Pond 200P: P-SUBSURFACE-2**

Peak Elev=122.60' Storage=0.131 af Inflow=3.17 cfs 0.331 af  
Outflow=0.90 cfs 0.330 af

**Pond 300P: P-SUBSURFACE-3**

Peak Elev=122.23' Storage=0.017 af Inflow=1.70 cfs 0.139 af  
Outflow=1.28 cfs 0.139 af

**Total Runoff Area = 7.951 ac Runoff Volume = 2.152 af Average Runoff Depth = 3.25"**  
**37.08% Pervious = 2.948 ac 62.92% Impervious = 5.003 ac**

**206327HC003A**

Prepared by Beals &amp; Thomas Inc

HydroCAD® 10.20-3c s/n 04493 © 2023 HydroCAD Software Solutions LLC

2063.27 Post-Development  
NRCC 24-hr D 100-Year Rainfall=8.36"

Printed 8/22/2023

Page 12

Time span=0.00-36.00 hrs, dt=0.05 hrs, 721 points  
 Runoff by SCS TR-20 method, UH=SCS, Weighted-CN  
 Reach routing by Stor-Ind+Trans method - Pond routing by Stor-Ind method

|                                      |   |
|--------------------------------------|---|
| <b>Subcatchment 101S: PDA-1A</b>     | Runoff Area=4.233 ac 58.72% Impervious Runoff Depth=5.13"<br>Flow Length=136' Tc=13.6 min CN=73 Runoff=18.03 cfs 1.810 af                       |
| <b>Subcatchment 102S: PDA-1B</b>     | Runoff Area=1.523 ac 52.30% Impervious Runoff Depth=4.54"<br>Flow Length=303' Tc=8.3 min CN=68 Runoff=6.92 cfs 0.576 af                         |
| <b>Subcatchment 111S: PDA-ROOF-1</b> | Runoff Area=0.585 ac 100.00% Impervious Runoff Depth=8.12"<br>Tc=6.0 min CN=98 Runoff=4.30 cfs 0.396 af   |
| <b>Subcatchment 201S: PDA-2A</b>     | Runoff Area=0.032 ac 0.00% Impervious Runoff Depth=0.67"<br>Tc=6.0 min CN=32 Runoff=0.01 cfs 0.002 af   |
| <b>Subcatchment 202S: PDA-2B</b>     | Runoff Area=0.600 ac 53.17% Impervious Runoff Depth=4.66"<br>Flow Length=205' Tc=14.1 min CN=69 Runoff=2.30 cfs 0.233 af                        |
| <b>Subcatchment 211S: PDA-ROOF-2</b> | Runoff Area=0.427 ac 100.00% Impervious Runoff Depth=8.12"<br>Tc=6.0 min CN=98 Runoff=3.13 cfs 0.289 af   |
| <b>Subcatchment 301S: PDA-3A</b>     | Runoff Area=0.126 ac 24.17% Impervious Runoff Depth=2.81"<br>Tc=6.0 min CN=53 Runoff=0.37 cfs 0.029 af  |
| <b>Subcatchment 302S: PDA-3B</b>     | Runoff Area=0.370 ac 83.79% Impervious Runoff Depth=6.92"<br>Tc=6.0 min CN=88 Runoff=2.55 cfs 0.213 af  |
| <b>Subcatchment 400S: PDA-4</b>      | Runoff Area=0.056 ac 88.26% Impervious Runoff Depth=7.28"<br>Tc=6.0 min CN=91 Runoff=0.39 cfs 0.034 af  |
| <b>Reach 100R: DP-1</b>              | Inflow=20.54 cfs 2.133 af<br>Outflow=20.54 cfs 2.133 af   |
| <b>Reach 200R: DP-2</b>              | Inflow=1.81 cfs 0.950 af<br>Outflow=1.81 cfs 0.950 af   |
| <b>Reach 300R: DP-3</b>              | Inflow=2.24 cfs 0.243 af<br>Outflow=2.24 cfs 0.243 af   |
| <b>Reach 400R: DP-4</b>              | Inflow=0.39 cfs 0.034 af<br>Outflow=0.39 cfs 0.034 af   |
| <b>Reach 500R: DP-5</b>              | Inflow=3.68 cfs 1.193 af<br>Outflow=3.68 cfs 1.193 af   |
| <b>Reach 600R: DP-6</b>              | Inflow=3.95 cfs 1.226 af<br>Outflow=3.95 cfs 1.226 af   |
| <b>Pond 100P: P-SUBSURFACE-1</b>     | Peak Elev=126.48' Storage=0.279 af Inflow=11.08 cfs 0.972 af<br>Discarded=0.61 cfs 0.649 af Primary=3.44 cfs 0.323 af Outflow=4.04 cfs 0.972 af |

**206327HC003A**

Prepared by Beals & Thomas Inc

HydroCAD® 10.20-3c s/n 04493 © 2023 HydroCAD Software Solutions LLC

2063.27 Post-Development  
NRCC 24-hr D 100-Year Rainfall=8.36"

Printed 8/22/2023

Page 13

**Pond 110P: E-POND**

Peak Elev=122.46' Storage=1.914 af Inflow=20.54 cfs 2.133 af  
4.0" Round Culvert n=0.012 L=275.0' S=0.0090 '/ Outflow=0.22 cfs 0.427 af

**Pond 200P: P-SUBSURFACE-2**

Peak Elev=123.78' Storage=0.186 af Inflow=4.94 cfs 0.522 af  
Outflow=1.60 cfs 0.521 af

**Pond 300P: P-SUBSURFACE-3**

Peak Elev=123.29' Storage=0.023 af Inflow=2.55 cfs 0.213 af  
Outflow=1.92 cfs 0.213 af

**Total Runoff Area = 7.951 ac Runoff Volume = 3.582 af Average Runoff Depth = 5.41"**  
**37.08% Pervious = 2.948 ac 62.92% Impervious = 5.003 ac**

**206327HC003A**

Prepared by Beals & Thomas Inc

HydroCAD® 10.20-3c s/n 04493 © 2023 HydroCAD Software Solutions LLC

2063.27 Post-Development  
NRCC 24-hr D 100-Year Rainfall=8.36"

Printed 8/22/2023

Page 14

**Summary for Subcatchment 101S: PDA-1A**

Runoff = 18.03 cfs @ 12.21 hrs, Volume= 1.810 af, Depth= 5.13"  
Routed to Reach 100R : DP-1

Runoff by SCS TR-20 method, UH=SCS, Weighted-CN, Time Span= 0.00-36.00 hrs, dt= 0.05 hrs  
NRCC 24-hr D 100-Year Rainfall=8.36"

| Area (ac) | CN | Description                   |
|-----------|----|-------------------------------|
| 0.899     | 39 | >75% Grass cover, Good, HSG A |
| 0.761     | 98 | Paved parking, HSG A          |
| 0.000     | 98 | Roofs, HSG A                  |
| 1.724     | 98 | Water Surface, HSG D          |
| 0.716     | 30 | Woods, Good, HSG A            |
| 0.132     | 77 | Woods, Good, HSG D            |
| 4.233     | 73 | Weighted Average              |
| 1.747     |    | 41.28% Pervious Area          |
| 2.486     |    | 58.72% Impervious Area        |

| Tc (min) | Length (feet) | Slope (ft/ft) | Velocity (ft/sec) | Capacity (cfs) | Description  |
|----------|---------------|---------------|-------------------|----------------|--|
| 12.6     | 50            | 0.0200        | 0.07              |                | <b>Sheet Flow, SHT</b><br>Woods: Light underbrush n= 0.400 P2= 3.09" |
| 0.9      | 62            | 0.0569        | 1.19              |                | <b>Shallow Concentrated Flow, SCF-1</b><br>Woodland Kv= 5.0 fps      |
| 0.1      | 24            | 0.2962        | 2.72              |                | <b>Shallow Concentrated Flow, SCF-2</b><br>Woodland Kv= 5.0 fps      |
| 13.6     | 136           | Total         |                   |                |  |

Subcatchment 101S: PDA-1A

Hydrograph

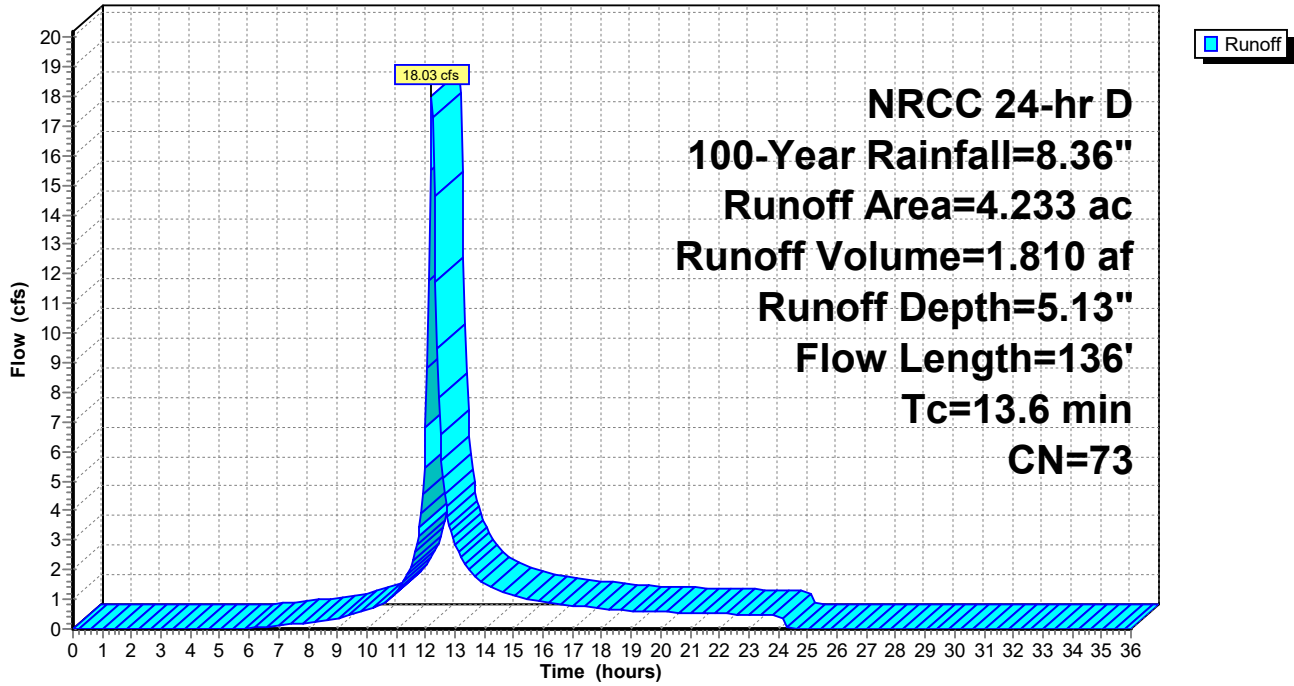

**206327HC003A**

Prepared by Beals &amp; Thomas Inc

HydroCAD® 10.20-3c s/n 04493 © 2023 HydroCAD Software Solutions LLC

2063.27 Post-Development

NRCC 24-hr D 100-Year Rainfall=8.36"

Printed 8/22/2023

Page 16

**Summary for Subcatchment 102S: PDA-1B**

Runoff = 6.92 cfs @ 12.15 hrs, Volume= 0.576 af, Depth= 4.54"  
 Routed to Pond 100P : P-SUBSURFACE-1

Runoff by SCS TR-20 method, UH=SCS, Weighted-CN, Time Span= 0.00-36.00 hrs, dt= 0.05 hrs  
 NRCC 24-hr D 100-Year Rainfall=8.36"

| Area (ac) | CN | Description                   |
|-----------|----|-------------------------------|
| 0.490     | 39 | >75% Grass cover, Good, HSG A |
| 0.695     | 98 | Paved parking, HSG A          |
| 0.102     | 98 | Roofs, HSG A                  |
| 0.236     | 30 | Woods, Good, HSG A            |
| 1.523     | 68 | Weighted Average              |
| 0.727     |    | 47.70% Pervious Area          |
| 0.797     |    | 52.30% Impervious Area        |

| Tc (min) | Length (feet) | Slope (ft/ft) | Velocity (ft/sec) | Capacity (cfs) | Description  |
|----------|---------------|---------------|-------------------|----------------|--|
| 6.6      | 50            | 0.1000        | 0.13              |                | <b>Sheet Flow, SHT</b><br>Woods: Light underbrush n= 0.400 P2= 3.09"       |
| 0.6      | 67            | 0.1348        | 1.84              |                | <b>Shallow Concentrated Flow, SCF-1</b><br>Woodland Kv= 5.0 fps            |
| 0.2      | 36            | 0.1348        | 2.57              |                | <b>Shallow Concentrated Flow, SCF-2</b><br>Short Grass Pasture Kv= 7.0 fps |
| 0.9      | 150           | 0.0200        | 2.87              |                | <b>Shallow Concentrated Flow, SCF-3</b><br>Paved Kv= 20.3 fps              |
| 8.3      | 303           | Total         |                   |                |  |

Subcatchment 102S: PDA-1B

Hydrograph

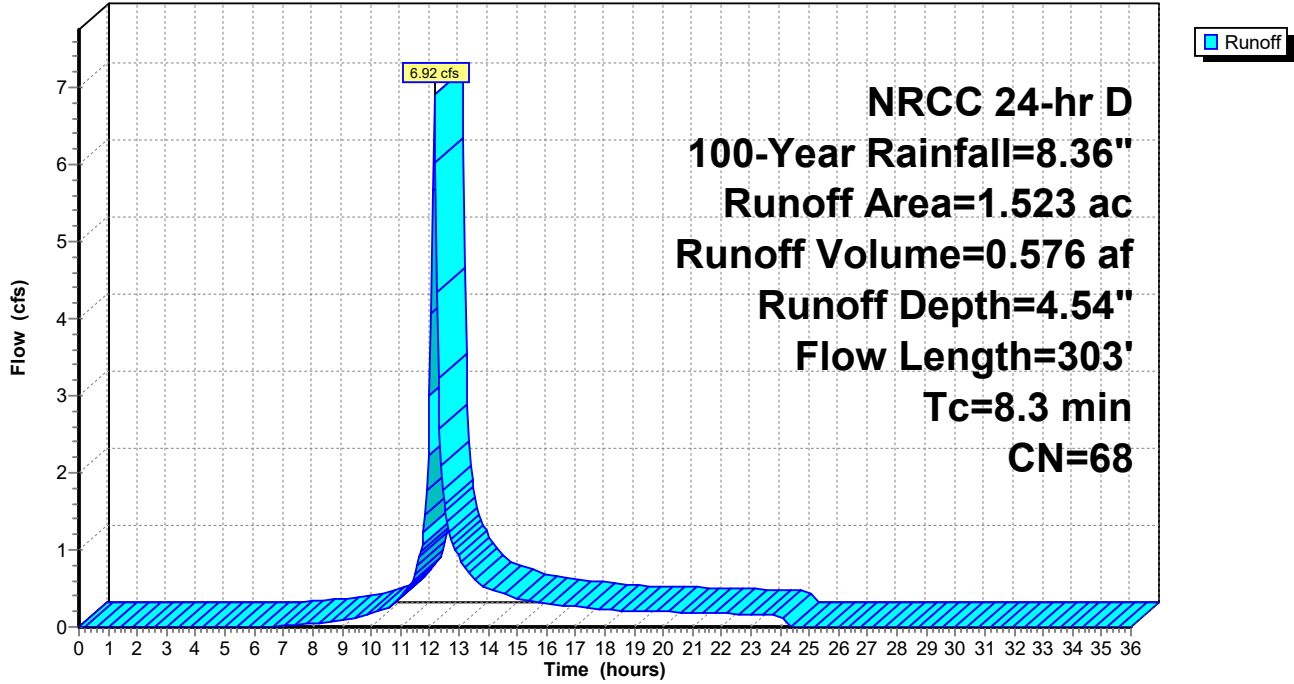

### Summary for Subcatchment 111S: PDA-ROOF-1

Runoff = 4.30 cfs @ 12.13 hrs, Volume= 0.396 af, Depth= 8.12"  
Routed to Pond 100P : P-SUBSURFACE-1

Runoff by SCS TR-20 method, UH=SCS, Weighted-CN, Time Span= 0.00-36.00 hrs, dt= 0.05 hrs  
NRCC 24-hr D 100-Year Rainfall=8.36"

| Area (ac) | CN | Description             |
|-----------|----|-------------------------|
| 0.585     | 98 | Roofs, HSG A            |
| 0.585     |    | 100.00% Impervious Area |

| Tc (min) | Length (feet) | Slope (ft/ft) | Velocity (ft/sec) | Capacity (cfs) | Description       |
|----------|---------------|---------------|-------------------|----------------|-------------------|
| 6.0      |               |               |                   |                | Direct Entry, MIN |

### Subcatchment 111S: PDA-ROOF-1

Hydrograph

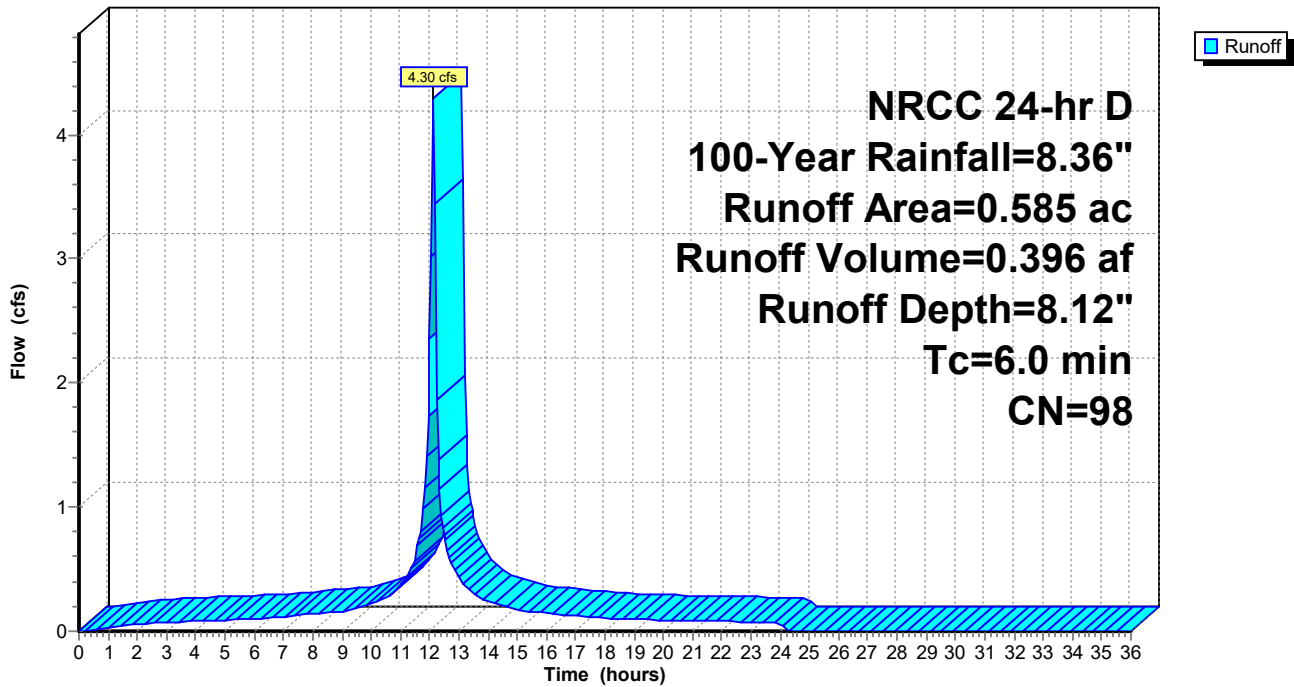

**206327HC003A**

Prepared by Beals & Thomas Inc

HydroCAD® 10.20-3c s/n 04493 © 2023 HydroCAD Software Solutions LLC

2063.27 Post-Development  
NRCC 24-hr D 100-Year Rainfall=8.36"

Printed 8/22/2023

Page 19

**Summary for Subcatchment 201S: PDA-2A**

Runoff = 0.01 cfs @ 12.21 hrs, Volume= 0.002 af, Depth= 0.67"  
Routed to Reach 200R : DP-2

Runoff by SCS TR-20 method, UH=SCS, Weighted-CN, Time Span= 0.00-36.00 hrs, dt= 0.05 hrs  
NRCC 24-hr D 100-Year Rainfall=8.36"

| Area (ac) | CN | Description                   |
|-----------|----|-------------------------------|
| 0.006     | 39 | >75% Grass cover, Good, HSG A |
| 0.026     | 30 | Woods, Good, HSG A            |
| 0.032     | 32 | Weighted Average              |
| 0.032     |    | 100.00% Pervious Area         |

| Tc (min) | Length (feet) | Slope (ft/ft) | Velocity (ft/sec) | Capacity (cfs) | Description       |
|----------|---------------|---------------|-------------------|----------------|-------------------|
| 6.0      |               |               |                   |                | Direct Entry, MIN |

**Subcatchment 201S: PDA-2A**

Hydrograph

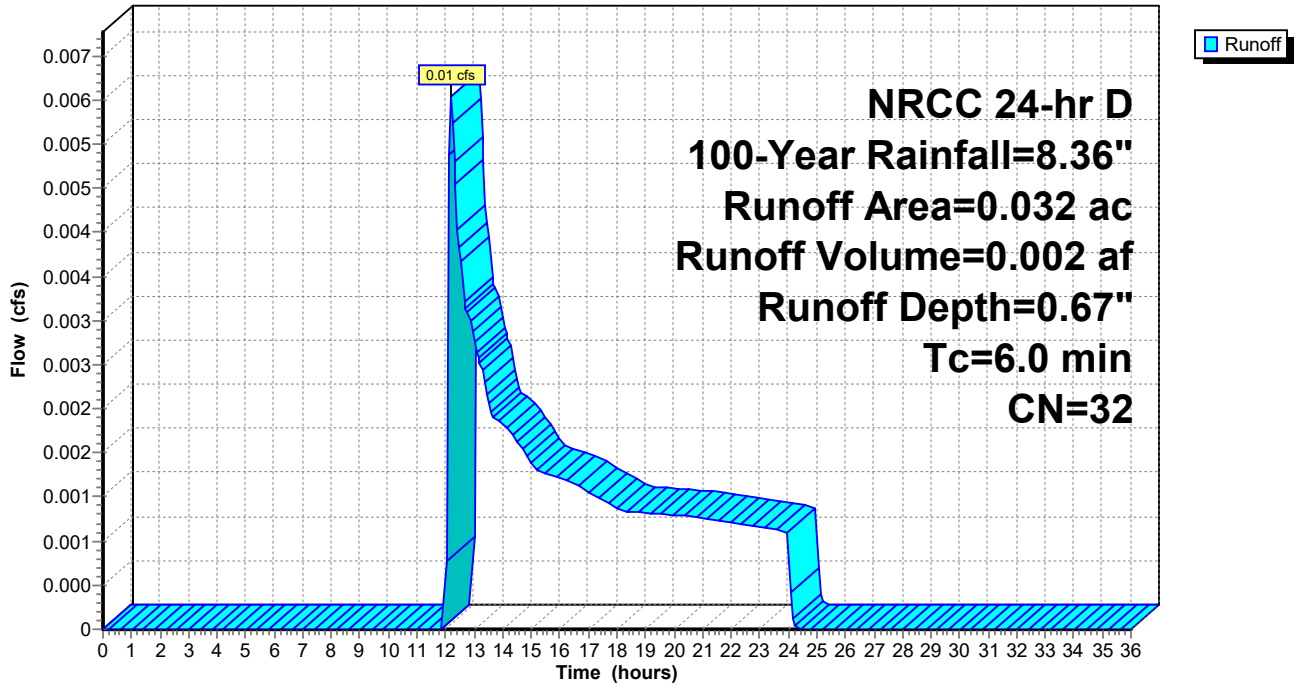

**206327HC003A**

Prepared by Beals &amp; Thomas Inc

HydroCAD® 10.20-3c s/n 04493 © 2023 HydroCAD Software Solutions LLC

2063.27 Post-Development  
NRCC 24-hr D 100-Year Rainfall=8.36"

Printed 8/22/2023

Page 20

**Summary for Subcatchment 202S: PDA-2B**

Runoff = 2.30 cfs @ 12.22 hrs, Volume= 0.233 af, Depth= 4.66"  
 Routed to Pond 200P : P-SUBSURFACE-2

Runoff by SCS TR-20 method, UH=SCS, Weighted-CN, Time Span= 0.00-36.00 hrs, dt= 0.05 hrs  
 NRCC 24-hr D 100-Year Rainfall=8.36"

| Area (ac) | CN | Description                   |
|-----------|----|-------------------------------|
| 0.197     | 39 | >75% Grass cover, Good, HSG A |
| 0.319     | 98 | Paved parking, HSG A          |
| 0.084     | 30 | Woods, Good, HSG A            |
| 0.600     | 69 | Weighted Average              |
| 0.281     |    | 46.83% Pervious Area          |
| 0.319     |    | 53.17% Impervious Area        |

| Tc (min) | Length (feet) | Slope (ft/ft) | Velocity (ft/sec) | Capacity (cfs) | Description  |
|----------|---------------|---------------|-------------------|----------------|--|
| 12.6     | 50            | 0.0200        | 0.07              |                | <b>Sheet Flow, SHT</b><br>Woods: Light underbrush n= 0.400 P2= 3.09"       |
| 0.1      | 21            | 0.1864        | 3.02              |                | <b>Shallow Concentrated Flow, SCF-1</b><br>Short Grass Pasture Kv= 7.0 fps |
| 0.5      | 27            | 0.0200        | 0.99              |                | <b>Shallow Concentrated Flow, SCF-2</b><br>Short Grass Pasture Kv= 7.0 fps |
| 0.9      | 107           | 0.0100        | 2.03              |                | <b>Shallow Concentrated Flow, SCF-3</b><br>Paved Kv= 20.3 fps              |
| 14.1     | 205           | Total         |                   |                |  |

Subcatchment 202S: PDA-2B

Hydrograph

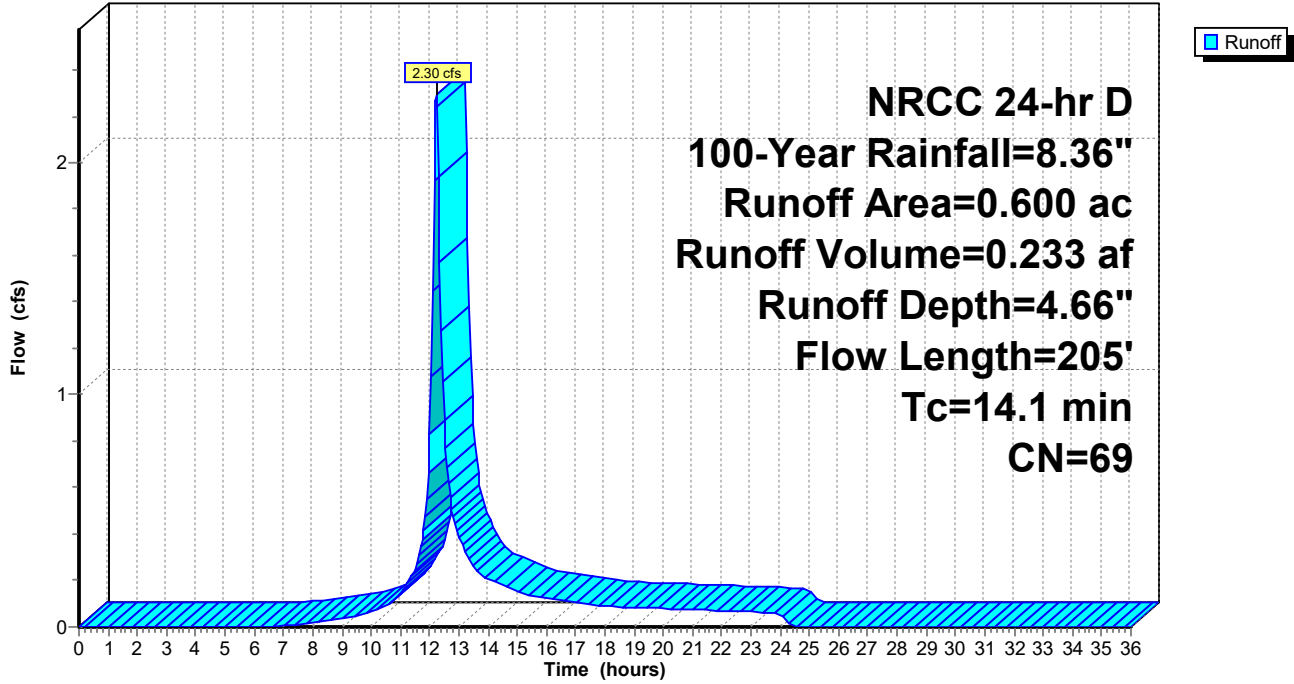

**206327HC003A**

Prepared by Beals & Thomas Inc

HydroCAD® 10.20-3c s/n 04493 © 2023 HydroCAD Software Solutions LLC

2063.27 Post-Development  
NRCC 24-hr D 100-Year Rainfall=8.36"

Printed 8/22/2023

Page 22

**Summary for Subcatchment 211S: PDA-ROOF-2**

Runoff = 3.13 cfs @ 12.13 hrs, Volume= 0.289 af, Depth= 8.12"  
Routed to Pond 200P : P-SUBSURFACE-2

Runoff by SCS TR-20 method, UH=SCS, Weighted-CN, Time Span= 0.00-36.00 hrs, dt= 0.05 hrs  
NRCC 24-hr D 100-Year Rainfall=8.36"

| Area (ac) | CN | Description             |
|-----------|----|-------------------------|
| 0.427     | 98 | Roofs, HSG A            |
| 0.427     |    | 100.00% Impervious Area |

| Tc (min) | Length (feet) | Slope (ft/ft) | Velocity (ft/sec) | Capacity (cfs) | Description       |
|----------|---------------|---------------|-------------------|----------------|-------------------|
| 6.0      |               |               |                   |                | Direct Entry, MIN |

**Subcatchment 211S: PDA-ROOF-2**

Hydrograph

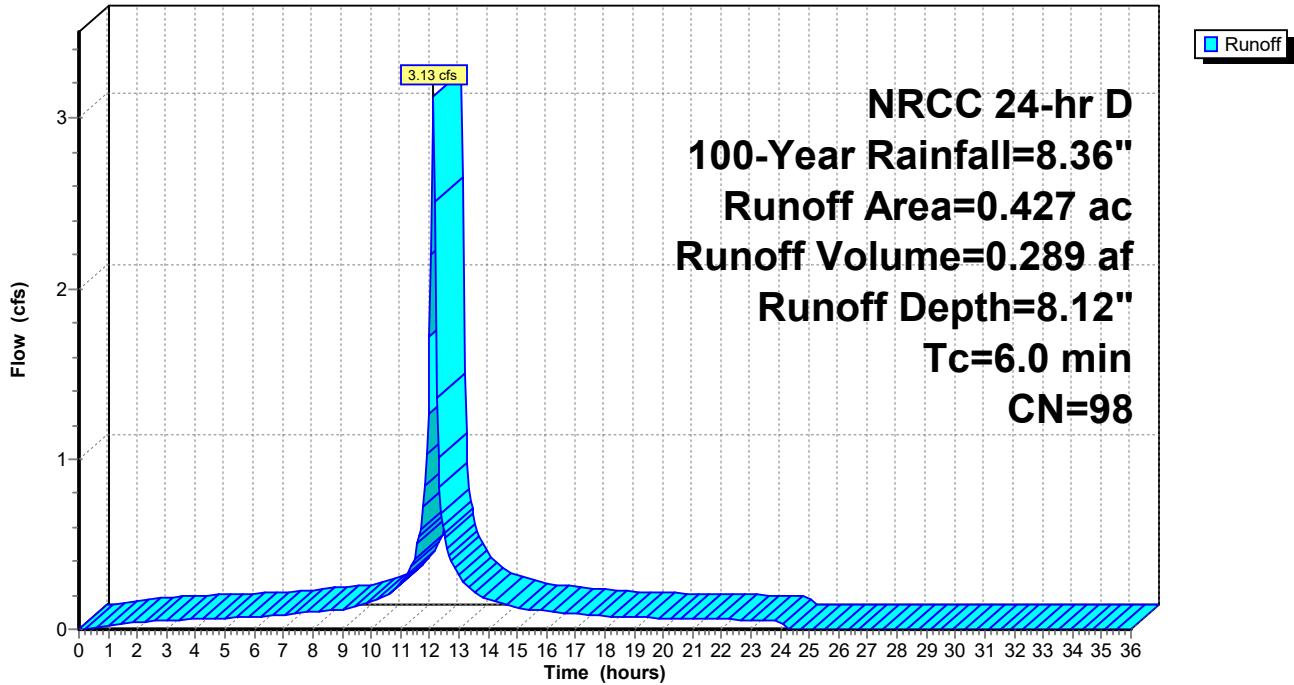

**206327HC003A**

Prepared by Beals & Thomas Inc

HydroCAD® 10.20-3c s/n 04493 © 2023 HydroCAD Software Solutions LLC

2063.27 Post-Development  
NRCC 24-hr D 100-Year Rainfall=8.36"

Printed 8/22/2023

Page 23

**Summary for Subcatchment 301S: PDA-3A**

Runoff = 0.37 cfs @ 12.14 hrs, Volume= 0.029 af, Depth= 2.81"  
Routed to Reach 300R : DP-3

Runoff by SCS TR-20 method, UH=SCS, Weighted-CN, Time Span= 0.00-36.00 hrs, dt= 0.05 hrs  
NRCC 24-hr D 100-Year Rainfall=8.36"

| Area (ac) | CN | Description                   |
|-----------|----|-------------------------------|
| 0.090     | 39 | >75% Grass cover, Good, HSG A |
| 0.030     | 98 | Paved parking, HSG A          |
| 0.005     | 30 | Woods, Good, HSG A            |
| 0.126     | 53 | Weighted Average              |
| 0.095     |    | 75.83% Pervious Area          |
| 0.030     |    | 24.17% Impervious Area        |

| Tc (min) | Length (feet) | Slope (ft/ft) | Velocity (ft/sec) | Capacity (cfs) | Description       |
|----------|---------------|---------------|-------------------|----------------|-------------------|
| 6.0      |               |               |                   |                | Direct Entry, MIN |

**Subcatchment 301S: PDA-3A**

Hydrograph

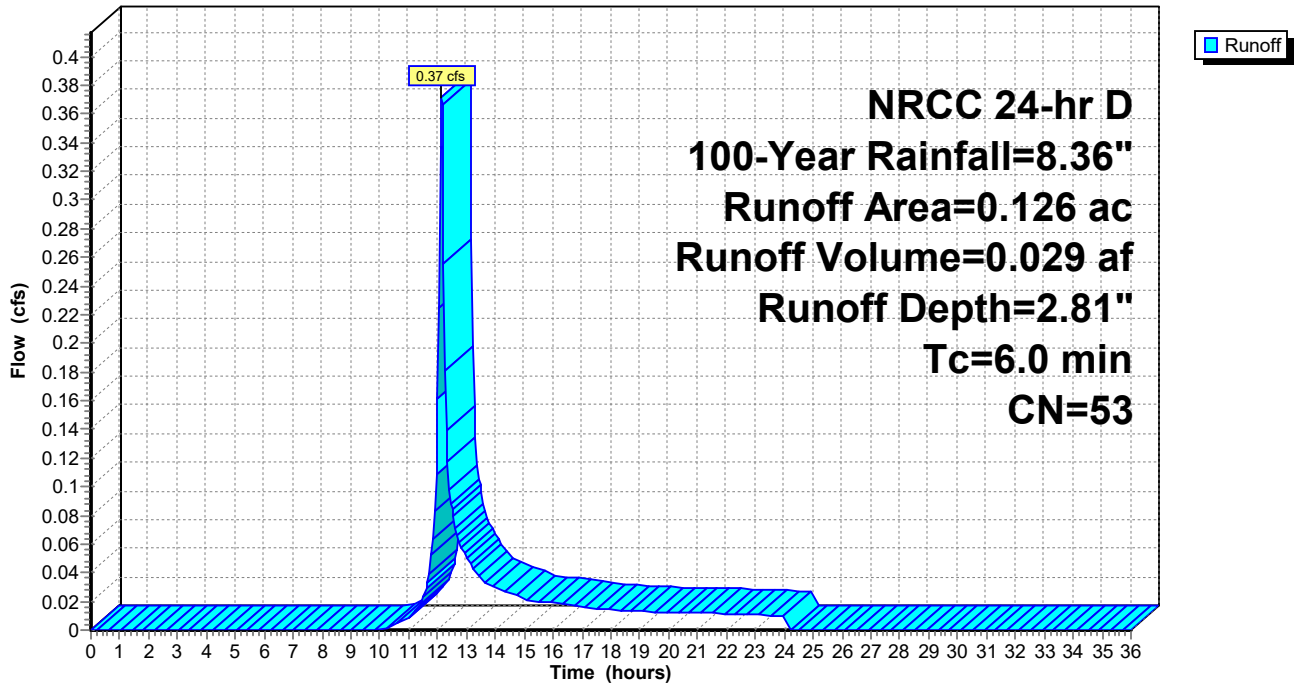

**206327HC003A**

Prepared by Beals & Thomas Inc

HydroCAD® 10.20-3c s/n 04493 © 2023 HydroCAD Software Solutions LLC

2063.27 Post-Development  
NRCC 24-hr D 100-Year Rainfall=8.36"

Printed 8/22/2023

Page 24

**Summary for Subcatchment 302S: PDA-3B**

Runoff = 2.55 cfs @ 12.13 hrs, Volume= 0.213 af, Depth= 6.92"  
Routed to Pond 300P : P-SUBSURFACE-3

Runoff by SCS TR-20 method, UH=SCS, Weighted-CN, Time Span= 0.00-36.00 hrs, dt= 0.05 hrs  
NRCC 24-hr D 100-Year Rainfall=8.36"

| Area (ac) | CN | Description                   |
|-----------|----|-------------------------------|
| 0.059     | 39 | >75% Grass cover, Good, HSG A |
| 0.247     | 98 | Paved parking, HSG A          |
| 0.063     | 98 | Roofs, HSG A                  |
| 0.001     | 30 | Woods, Good, HSG A            |
| 0.370     | 88 | Weighted Average              |
| 0.060     |    | 16.21% Pervious Area          |
| 0.310     |    | 83.79% Impervious Area        |

| Tc (min) | Length (feet) | Slope (ft/ft) | Velocity (ft/sec) | Capacity (cfs) | Description       |
|----------|---------------|---------------|-------------------|----------------|-------------------|
| 6.0      |               |               |                   |                | Direct Entry, MIN |

**Subcatchment 302S: PDA-3B**

Hydrograph

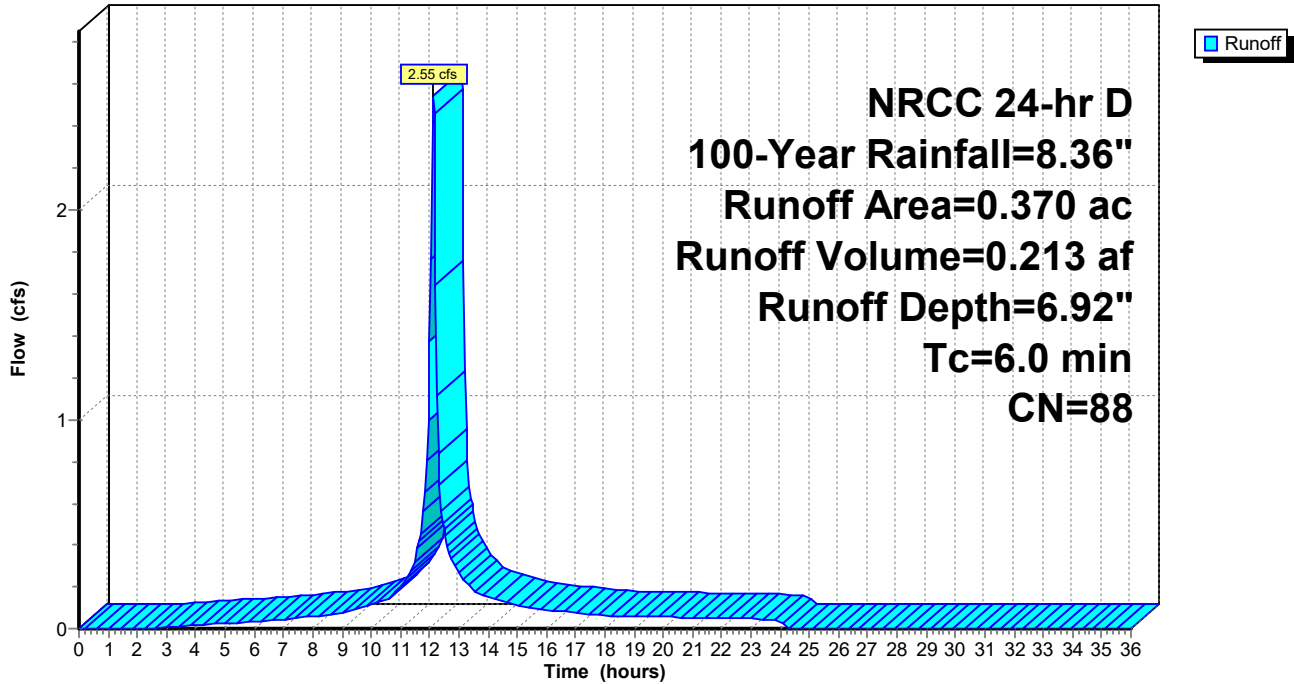

**206327HC003A**

Prepared by Beals & Thomas Inc

HydroCAD® 10.20-3c s/n 04493 © 2023 HydroCAD Software Solutions LLC

2063.27 Post-Development  
NRCC 24-hr D 100-Year Rainfall=8.36"

Printed 8/22/2023

Page 25

**Summary for Subcatchment 400S: PDA-4**

Runoff = 0.39 cfs @ 12.13 hrs, Volume= 0.034 af, Depth= 7.28"  
Routed to Reach 400R : DP-4

Runoff by SCS TR-20 method, UH=SCS, Weighted-CN, Time Span= 0.00-36.00 hrs, dt= 0.05 hrs  
NRCC 24-hr D 100-Year Rainfall=8.36"

| Area (ac) | CN | Description                   |
|-----------|----|-------------------------------|
| 0.007     | 39 | >75% Grass cover, Good, HSG A |
| 0.049     | 98 | Paved parking, HSG A          |
| 0.056     | 91 | Weighted Average              |
| 0.007     |    | 11.74% Pervious Area          |
| 0.049     |    | 88.26% Impervious Area        |

| Tc (min) | Length (feet) | Slope (ft/ft) | Velocity (ft/sec) | Capacity (cfs) | Description       |
|----------|---------------|---------------|-------------------|----------------|-------------------|
| 6.0      |               |               |                   |                | Direct Entry, MIN |

**Subcatchment 400S: PDA-4**

Hydrograph

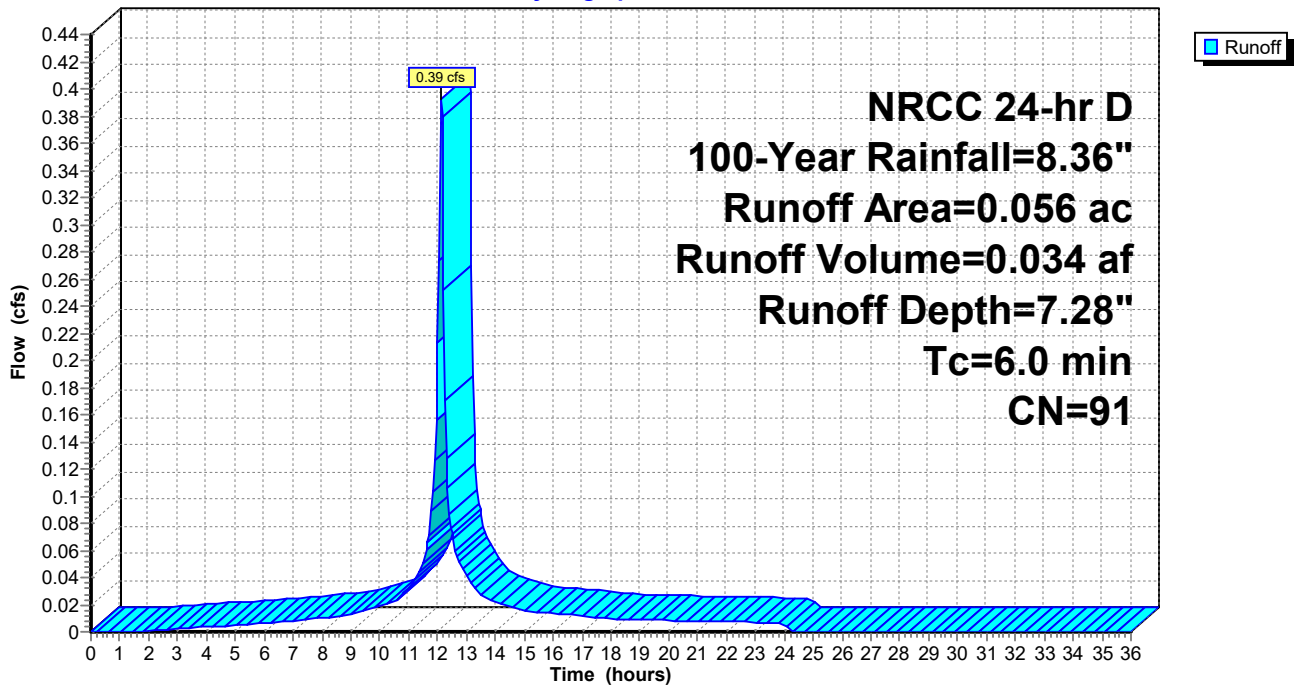

### Summary for Reach 100R: DP-1

[40] Hint: Not Described (Outflow=Inflow)

Inflow Area = 6.342 ac, 60.99% Impervious, Inflow Depth = 4.04" for 100-Year event  
Inflow = 20.54 cfs @ 12.23 hrs, Volume= 2.133 af  
Outflow = 20.54 cfs @ 12.23 hrs, Volume= 2.133 af, Atten= 0%, Lag= 0.0 min  
Routed to Pond 110P : E-POND

Routing by Stor-Ind+Trans method, Time Span= 0.00-36.00 hrs, dt= 0.05 hrs

### Reach 100R: DP-1

#### Hydrograph

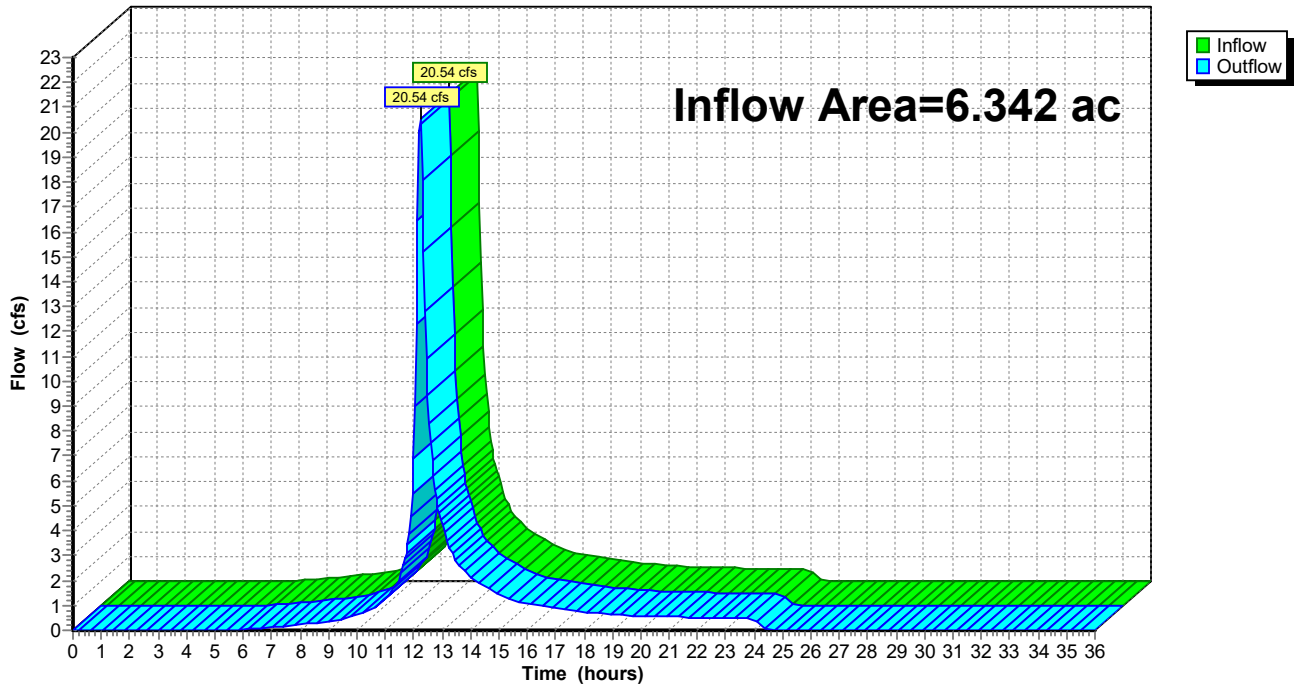

### Summary for Reach 200R: DP-2

[40] Hint: Not Described (Outflow=Inflow)

Inflow Area = 7.400 ac, 62.35% Impervious, Inflow Depth > 1.54" for 100-Year event  
Inflow = 1.81 cfs @ 12.47 hrs, Volume= 0.950 af  
Outflow = 1.81 cfs @ 12.47 hrs, Volume= 0.950 af, Atten= 0%, Lag= 0.0 min  
Routed to Reach 500R : DP-5

Routing by Stor-Ind+Trans method, Time Span= 0.00-36.00 hrs, dt= 0.05 hrs

### Reach 200R: DP-2

#### Hydrograph

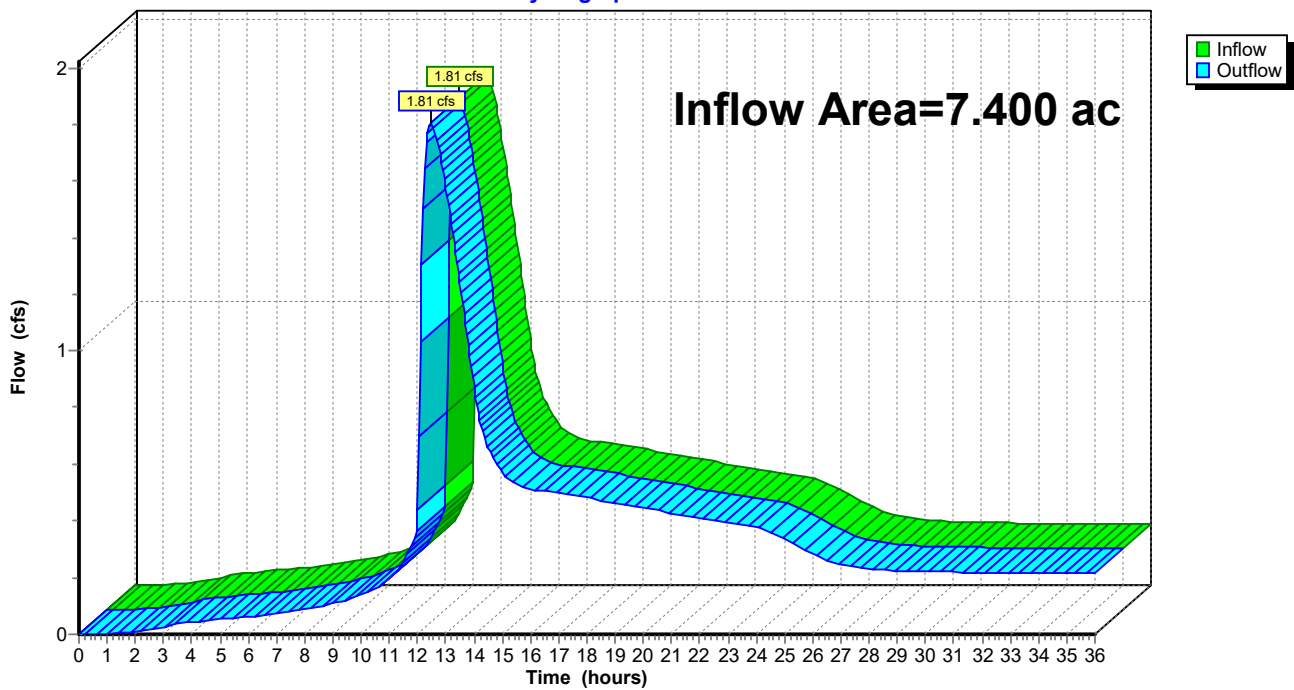

### Summary for Reach 300R: DP-3

[40] Hint: Not Described (Outflow=Inflow)

Inflow Area = 0.496 ac, 68.65% Impervious, Inflow Depth = 5.88" for 100-Year event  
Inflow = 2.24 cfs @ 12.17 hrs, Volume= 0.243 af  
Outflow = 2.24 cfs @ 12.17 hrs, Volume= 0.243 af, Atten= 0%, Lag= 0.0 min  
Routed to Reach 500R : DP-5

Routing by Stor-Ind+Trans method, Time Span= 0.00-36.00 hrs, dt= 0.05 hrs

### Reach 300R: DP-3

Hydrograph

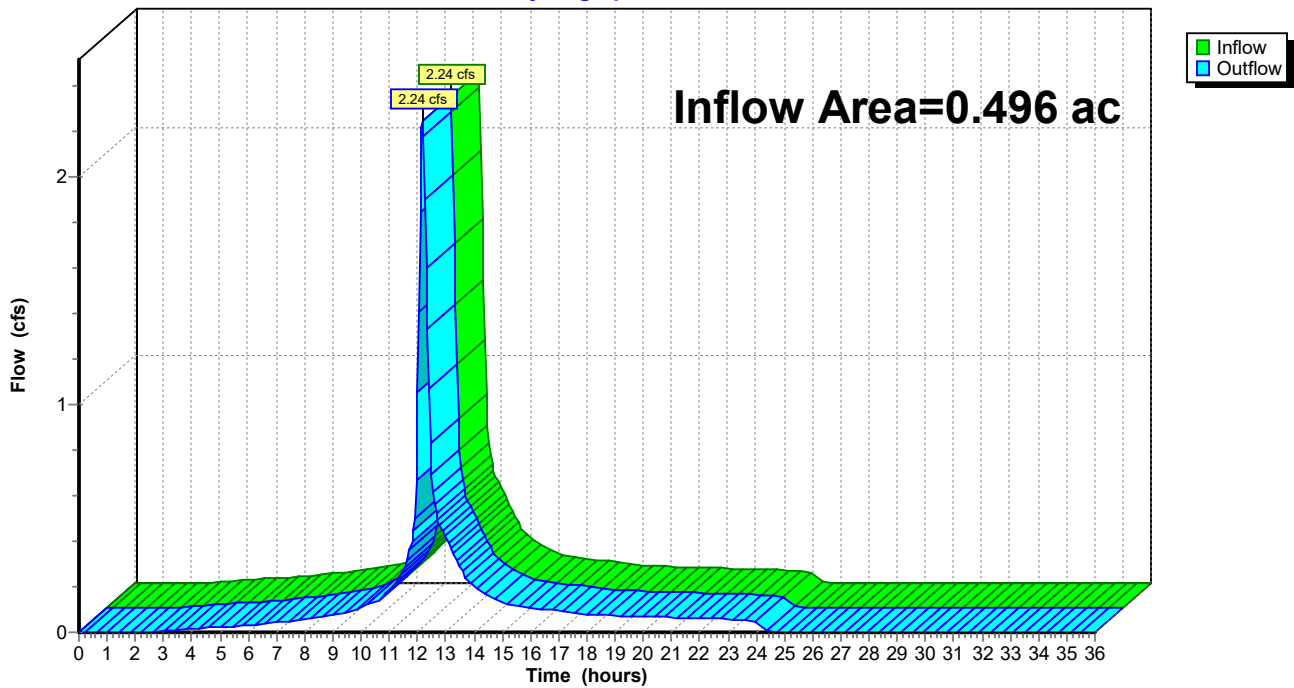

### Summary for Reach 400R: DP-4

[40] Hint: Not Described (Outflow=Inflow)

Inflow Area = 0.056 ac, 88.26% Impervious, Inflow Depth = 7.28" for 100-Year event  
Inflow = 0.39 cfs @ 12.13 hrs, Volume= 0.034 af  
Outflow = 0.39 cfs @ 12.13 hrs, Volume= 0.034 af, Atten= 0%, Lag= 0.0 min  
Routed to Reach 600R : DP-6

Routing by Stor-Ind+Trans method, Time Span= 0.00-36.00 hrs, dt= 0.05 hrs

### Reach 400R: DP-4

#### Hydrograph

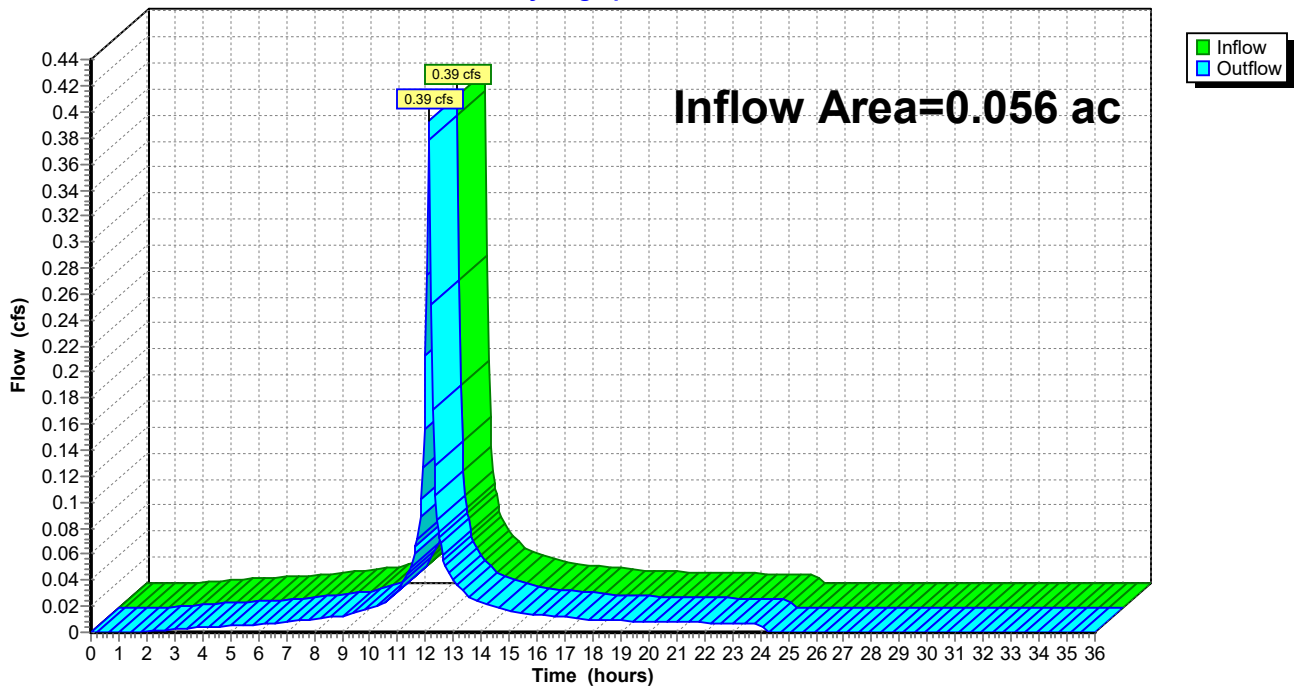

### Summary for Reach 500R: DP-5

[40] Hint: Not Described (Outflow=Inflow)

Inflow Area = 7.896 ac, 62.74% Impervious, Inflow Depth > 1.81" for 100-Year event  
Inflow = 3.68 cfs @ 12.20 hrs, Volume= 1.193 af  
Outflow = 3.68 cfs @ 12.20 hrs, Volume= 1.193 af, Atten= 0%, Lag= 0.0 min  
Routed to Reach 600R : DP-6

Routing by Stor-Ind+Trans method, Time Span= 0.00-36.00 hrs, dt= 0.05 hrs

### Reach 500R: DP-5

Hydrograph

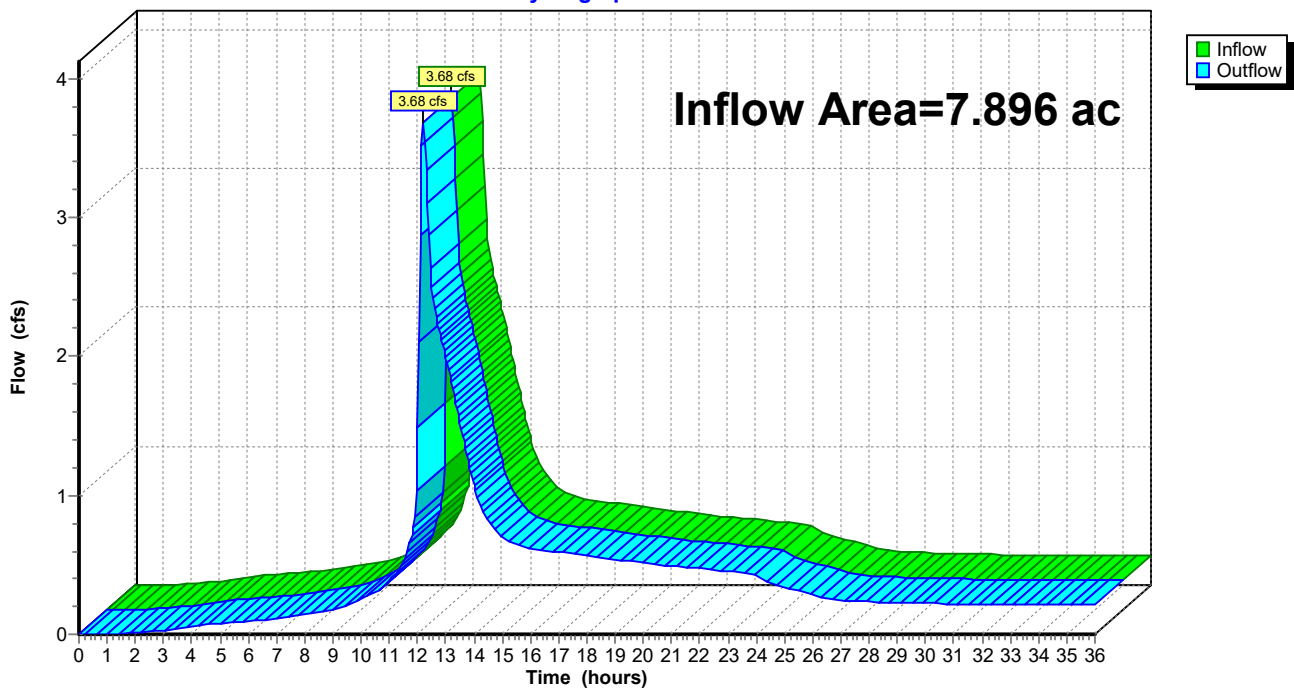

### Summary for Reach 600R: DP-6

[40] Hint: Not Described (Outflow=Inflow)

Inflow Area = 7.951 ac, 62.92% Impervious, Inflow Depth > 1.85" for 100-Year event  
Inflow = 3.95 cfs @ 12.18 hrs, Volume= 1.226 af  
Outflow = 3.95 cfs @ 12.18 hrs, Volume= 1.226 af, Atten= 0%, Lag= 0.0 min

Routing by Stor-Ind+Trans method, Time Span= 0.00-36.00 hrs, dt= 0.05 hrs

### Reach 600R: DP-6

Hydrograph

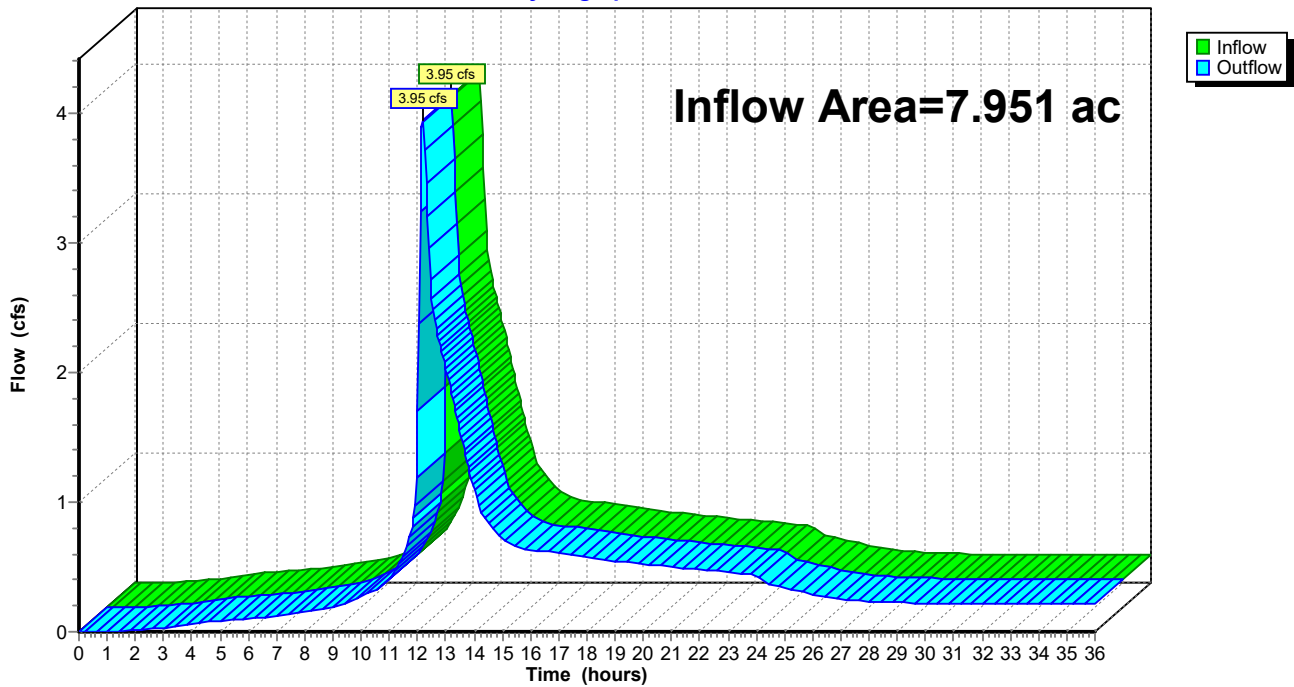

**206327HC003A**

Prepared by Beals & Thomas Inc

HydroCAD® 10.20-3c s/n 04493 © 2023 HydroCAD Software Solutions LLC

**Summary for Pond 100P: P-SUBSURFACE-1**

Inflow Area = 2.109 ac, 65.54% Impervious, Inflow Depth = 5.53" for 100-Year event  
Inflow = 11.08 cfs @ 12.14 hrs, Volume= 0.972 af  
Outflow = 4.04 cfs @ 12.33 hrs, Volume= 0.972 af, Atten= 64%, Lag= 11.5 min  
Discarded = 0.61 cfs @ 12.33 hrs, Volume= 0.649 af  
Primary = 3.44 cfs @ 12.33 hrs, Volume= 0.323 af  
Routed to Reach 100R : DP-1

Routing by Stor-Ind method, Time Span= 0.00-36.00 hrs, dt= 0.05 hrs  
Peak Elev= 126.48' @ 12.33 hrs Surf.Area= 0.127 ac Storage= 0.279 af

Plug-Flow detention time= 107.4 min calculated for 0.972 af (100% of inflow)  
Center-of-Mass det. time= 107.3 min ( 914.8 - 807.5 )

| Volume | Invert  | Avail.Storage | Storage Description  |
|--------|---------|---------------|--|
| #1A    | 124.00' | 0.000 af      | <b>30.27'W x 182.67'L x 3.50'H Field A</b><br>0.444 af Overall - 0.444 af Embedded = 0.000 af x 40.0% Voids  |
| #2A    | 124.00' | 0.337 af      | <b>StormTrap ST2 SingleTrap 3-0 x 22 Inside #1</b><br>Inside= 101.7"W x 36.0"H => 22.99 sf x 15.40'L = 354.0 cf<br>Outside= 101.7"W x 42.0"H => 29.68 sf x 15.40'L = 456.9 cf<br>22 Chambers in 2 Rows<br>16.96' x 169.35' Core + 6.66' Border = 30.27' x 182.67' System |
|        |         | 0.337 af      | Total Available Storage  |

Storage Group A created with Chamber Wizard

| Device | Routing   | Invert  | Outlet Devices  |
|--------|-----------|---------|---|
| #1     | Primary   | 124.85' | <b>15.0" Round Culvert</b><br>L= 170.0' CPP, square edge headwall, Ke= 0.500<br>Inlet / Outlet Invert= 124.85' / 124.00' S= 0.0050 '/' Cc= 0.900<br>n= 0.013 Corrugated PE, smooth interior, Flow Area= 1.23 sf |
| #2     | Device 1  | 124.85' | <b>3.0" Vert. Orifice/Grate</b> C= 0.600 Limited to weir flow at low heads  |
| #3     | Device 1  | 125.30' | <b>6.0" Vert. Orifice/Grate</b> C= 0.600 Limited to weir flow at low heads  |
| #4     | Device 1  | 125.90' | <b>1.6' long x 2.10' rise Sharp-Crested Rectangular Weir</b><br>2 End Contraction(s) 1.9' Crest Height  |
| #5     | Discarded | 124.00' | <b>2.410 in/hr Exfiltration over Horizontal area</b><br>Conductivity to Groundwater Elevation = 121.42'   |

**Discarded OutFlow** Max=0.60 cfs @ 12.33 hrs HW=126.48' (Free Discharge)  
↑5=Exfiltration ( Controls 0.60 cfs)

**Primary OutFlow** Max=3.42 cfs @ 12.33 hrs HW=126.48' (Free Discharge)  
↑1=Culvert (Passes 3.42 cfs of 4.91 cfs potential flow)  
↑2=Orifice/Grate (Orifice Controls 0.29 cfs @ 5.91 fps)  
↑3=Orifice/Grate (Orifice Controls 0.91 cfs @ 4.64 fps)  
↑4=Sharp-Crested Rectangular Weir (Weir Controls 2.22 cfs @ 2.58 fps)

**206327HC003A**

Prepared by Beals & Thomas Inc

HydroCAD® 10.20-3c s/n 04493 © 2023 HydroCAD Software Solutions LLC

**Pond 100P: P-SUBSURFACE-1 - Chamber Wizard Field A**

**Chamber Model = StormTrap ST2 SingleTrap 3-0 (StormTrap ST2 SingleTrap® Type II+IV)**

Inside= 101.7"W x 36.0"H => 22.99 sf x 15.40'L = 354.0 cf

Outside= 101.7"W x 42.0"H => 29.68 sf x 15.40'L = 456.9 cf

11 Chambers/Row x 15.40' Long = 169.35' Row Length +79.9" Border x 2 = 182.67' Base Length

2 Rows x 101.7" Wide + 79.9" Side Border x 2 = 30.27' Base Width

42.0" Chamber Height = 3.50' Field Height

22 Chambers x 354.0 cf + 6,906.5 cf Border = 14,694.3 cf Chamber Storage

22 Chambers x 456.9 cf + 9,301.3 cf Border = 19,353.2 cf Displacement

Chamber Storage = 14,694.3 cf = 0.337 af

Overall Storage Efficiency = 75.9%

Overall System Size = 182.67' x 30.27' x 3.50'

22 Chambers (plus border)

716.8 cy Field

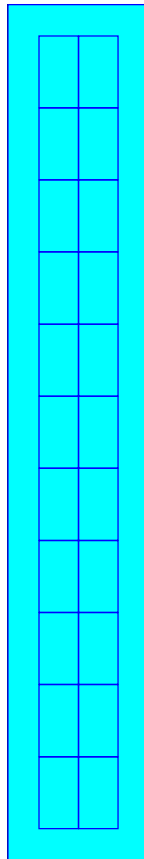

Pond 100P: P-SUBSURFACE-1

Hydrograph

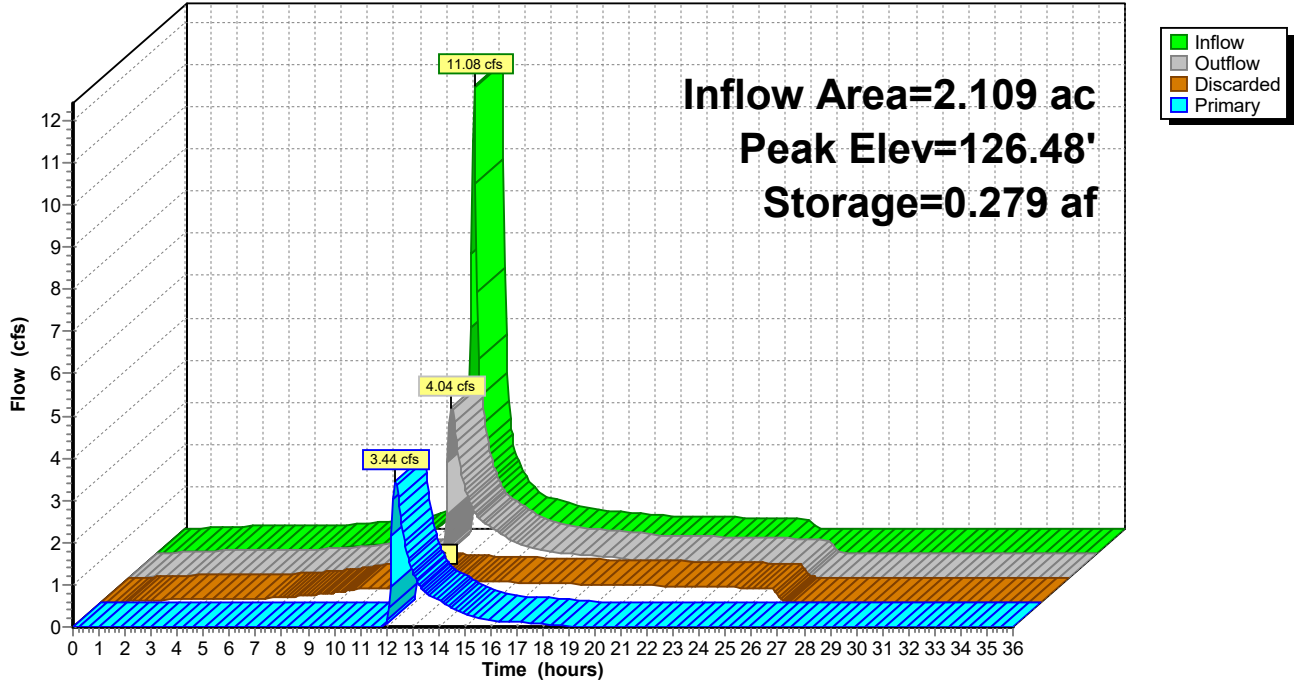

**206327HC003A**

Prepared by Beals &amp; Thomas Inc

HydroCAD® 10.20-3c s/n 04493 © 2023 HydroCAD Software Solutions LLC

2063.27 Post-Development

NRCC 24-hr D 100-Year Rainfall=8.36"

Printed 8/22/2023

Page 35

**Stage-Area-Storage for Pond 100P: P-SUBSURFACE-1**

| Elevation<br>(feet) | Horizontal<br>(acres) | Storage<br>(acre-feet) | Elevation<br>(feet) | Horizontal<br>(acres) | Storage<br>(acre-feet) |
|---------------------|-----------------------|------------------------|---------------------|-----------------------|------------------------|
| 124.00              | <b>0.127</b>          | 0.000                  | 126.55              | 0.127                 | 0.287                  |
| 124.05              | 0.127                 | 0.006                  | 126.60              | 0.127                 | 0.292                  |
| 124.10              | 0.127                 | 0.011                  | 126.65              | 0.127                 | 0.298                  |
| 124.15              | 0.127                 | 0.017                  | 126.70              | 0.127                 | 0.304                  |
| 124.20              | 0.127                 | 0.022                  | 126.75              | 0.127                 | 0.309                  |
| 124.25              | 0.127                 | 0.028                  | 126.80              | 0.127                 | 0.315                  |
| 124.30              | 0.127                 | 0.034                  | 126.85              | 0.127                 | 0.320                  |
| 124.35              | 0.127                 | 0.039                  | 126.90              | 0.127                 | 0.326                  |
| 124.40              | 0.127                 | 0.045                  | 126.95              | 0.127                 | 0.332                  |
| 124.45              | 0.127                 | 0.051                  | 127.00              | 0.127                 | 0.337                  |
| 124.50              | 0.127                 | 0.056                  | 127.05              | 0.127                 | 0.337                  |
| 124.55              | 0.127                 | 0.062                  | 127.10              | 0.127                 | 0.337                  |
| 124.60              | 0.127                 | 0.067                  | 127.15              | 0.127                 | 0.337                  |
| 124.65              | 0.127                 | 0.073                  | 127.20              | 0.127                 | 0.337                  |
| 124.70              | 0.127                 | 0.079                  | 127.25              | 0.127                 | <b>0.337</b>           |
| 124.75              | 0.127                 | 0.084                  | 127.30              | 0.127                 | <b>0.337</b>           |
| 124.80              | 0.127                 | 0.090                  | 127.35              | 0.127                 | 0.337                  |
| <b>124.85</b>       | <b>0.127</b>          | <b>0.096</b>           | 127.40              | 0.127                 | 0.337                  |
| 124.90              | 0.127                 | 0.101                  | 127.45              | 0.127                 | 0.337                  |
| 124.95              | 0.127                 | 0.107                  | 127.50              | 0.127                 | 0.337                  |
| 125.00              | 0.127                 | 0.112                  | 127.55              | 0.127                 | 0.337                  |
| 125.05              | 0.127                 | 0.118                  | 127.60              | 0.127                 | 0.337                  |
| 125.10              | 0.127                 | 0.124                  | 127.65              | 0.127                 | 0.337                  |
| 125.15              | 0.127                 | 0.129                  | 127.70              | 0.127                 | 0.337                  |
| 125.20              | 0.127                 | 0.135                  | 127.75              | 0.127                 | 0.337                  |
| 125.25              | 0.127                 | 0.141                  | 127.80              | 0.127                 | 0.337                  |
| 125.30              | 0.127                 | 0.146                  | 127.85              | 0.127                 | 0.337                  |
| 125.35              | 0.127                 | 0.152                  | 127.90              | 0.127                 | 0.337                  |
| 125.40              | 0.127                 | 0.157                  | 127.95              | 0.127                 | 0.337                  |
| 125.45              | 0.127                 | 0.163                  | 128.00              | 0.127                 | 0.337                  |
| 125.50              | 0.127                 | 0.169                  |                     |                       |                        |
| 125.55              | 0.127                 | 0.174                  |                     |                       |                        |
| 125.60              | 0.127                 | 0.180                  |                     |                       |                        |
| 125.65              | 0.127                 | 0.186                  |                     |                       |                        |
| 125.70              | 0.127                 | 0.191                  |                     |                       |                        |
| 125.75              | 0.127                 | 0.197                  |                     |                       |                        |
| 125.80              | 0.127                 | 0.202                  |                     |                       |                        |
| 125.85              | 0.127                 | 0.208                  |                     |                       |                        |
| 125.90              | 0.127                 | 0.214                  |                     |                       |                        |
| 125.95              | 0.127                 | 0.219                  |                     |                       |                        |
| 126.00              | 0.127                 | 0.225                  |                     |                       |                        |
| 126.05              | 0.127                 | 0.231                  |                     |                       |                        |
| 126.10              | 0.127                 | 0.236                  |                     |                       |                        |
| 126.15              | 0.127                 | 0.242                  |                     |                       |                        |
| 126.20              | 0.127                 | 0.247                  |                     |                       |                        |
| 126.25              | 0.127                 | 0.253                  |                     |                       |                        |
| 126.30              | 0.127                 | 0.259                  |                     |                       |                        |
| 126.35              | 0.127                 | 0.264                  |                     |                       |                        |
| 126.40              | 0.127                 | 0.270                  |                     |                       |                        |
| 126.45              | 0.127                 | 0.275                  |                     |                       |                        |
| 126.50              | 0.127                 | 0.281                  |                     |                       |                        |

**206327HC003A**

Prepared by Beals & Thomas Inc

HydroCAD® 10.20-3c s/n 04493 © 2023 HydroCAD Software Solutions LLC

2063.27 Post-Development  
NRCC 24-hr D 100-Year Rainfall=8.36"

Printed 8/22/2023

Page 36

**Summary for Pond 110P: E-POND**

Inflow Area = 6.342 ac, 60.99% Impervious, Inflow Depth = 4.04" for 100-Year event  
Inflow = 20.54 cfs @ 12.23 hrs, Volume= 2.133 af  
Outflow = 0.22 cfs @ 24.20 hrs, Volume= 0.427 af, Atten= 99%, Lag= 718.3 min  
Primary = 0.22 cfs @ 24.20 hrs, Volume= 0.427 af  
Routed to Reach 200R : DP-2

Routing by Stor-Ind method, Time Span= 0.00-36.00 hrs, dt= 0.05 hrs  
Peak Elev= 122.46' @ 24.20 hrs Surf.Area= 1.915 ac Storage= 1.914 af

Plug-Flow detention time= 781.5 min calculated for 0.427 af (20% of inflow)  
Center-of-Mass det. time= 600.9 min ( 1,439.3 - 838.5 )

| Volume              | Invert               | Avail.Storage            | Storage Description  |
|---------------------|----------------------|--------------------------|--|
| #1                  | 121.40'              | 2.981 af                 | <b>Custom Stage Data (Prismatic)</b> Listed below (Recalc) |
| Elevation<br>(feet) | Surf.Area<br>(acres) | Inc.Store<br>(acre-feet) | Cum.Store<br>(acre-feet)                                   |
| 121.40              | 1.720                | 0.000                    | 0.000  |
| 122.00              | 1.800                | 1.056                    | 1.056  |
| 123.00              | 2.050                | 1.925                    | 2.981  |

| Device | Routing | Invert  | Outlet Devices  |
|--------|---------|---------|---|
| #1     | Primary | 121.40' | <b>4.0" Round Culvert</b><br>L= 275.0' CMP, end-section conforming to fill, Ke= 0.500<br>Inlet / Outlet Invert= 121.40' / 118.93' S= 0.0090 '/' Cc= 0.900<br>n= 0.012, Flow Area= 0.09 sf |

**Primary OutFlow** Max=0.22 cfs @ 24.20 hrs HW=122.46' (Free Discharge)  
↑**1=Culvert** (Barrel Controls 0.22 cfs @ 2.49 fps)

### Pond 110P: E-POND

Hydrograph

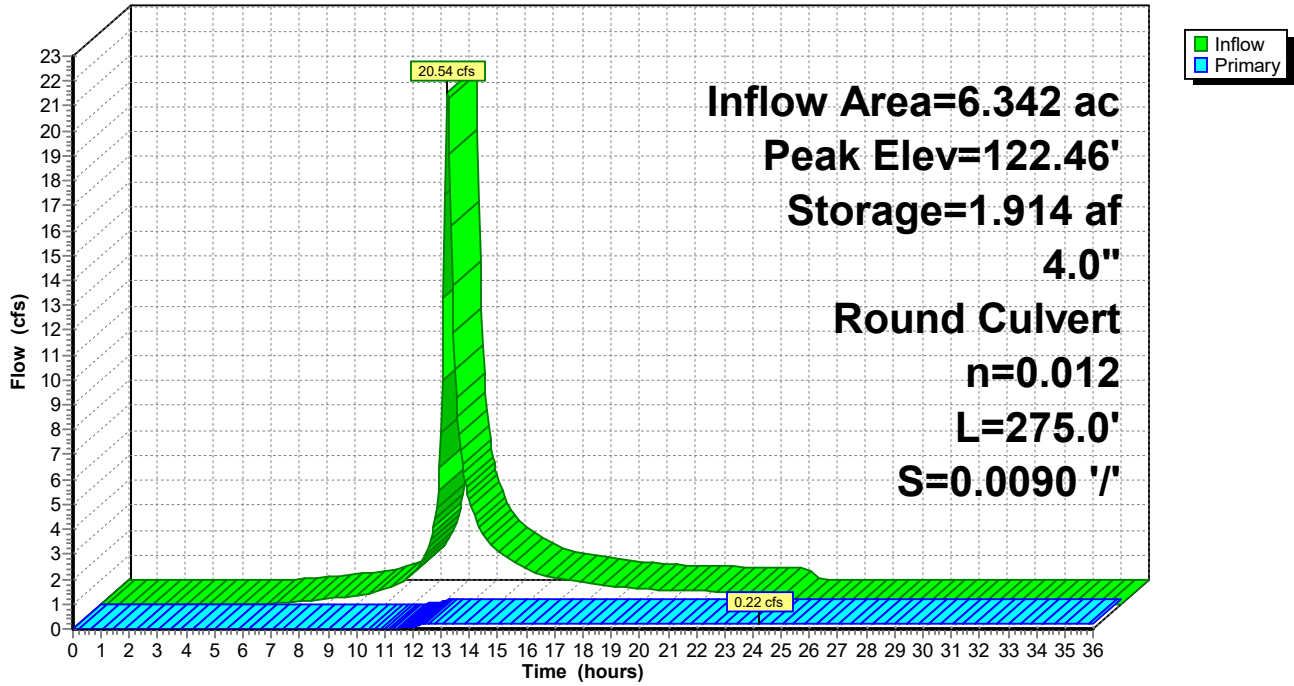

**206327HC003A**

Prepared by Beals &amp; Thomas Inc

HydroCAD® 10.20-3c s/n 04493 © 2023 HydroCAD Software Solutions LLC

2063.27 Post-Development

NRCC 24-hr D 100-Year Rainfall=8.36"

Printed 8/22/2023

Page 38

**Stage-Area-Storage for Pond 110P: E-POND**

| Elevation<br>(feet) | Surface<br>(acres) | Storage<br>(acre-feet) | Elevation<br>(feet) | Surface<br>(acres) | Storage<br>(acre-feet) |
|---------------------|--------------------|------------------------|---------------------|--------------------|------------------------|
| 121.40              | 1.720              | 0.000                  | 122.42              | 1.905              | 1.834                  |
| 121.42              | 1.723              | 0.034                  | 122.44              | 1.910              | 1.872                  |
| 121.44              | 1.725              | 0.069                  | 122.46              | 1.915              | 1.910                  |
| 121.46              | 1.728              | 0.103                  | 122.48              | 1.920              | 1.949                  |
| 121.48              | 1.731              | 0.138                  | 122.50              | 1.925              | 1.987                  |
| 121.50              | 1.733              | 0.173                  | 122.52              | 1.930              | 2.026                  |
| 121.52              | 1.736              | 0.207                  | 122.54              | 1.935              | 2.064                  |
| 121.54              | 1.739              | 0.242                  | 122.56              | 1.940              | 2.103                  |
| 121.56              | 1.741              | 0.277                  | 122.58              | 1.945              | 2.142                  |
| 121.58              | 1.744              | 0.312                  | 122.60              | 1.950              | 2.181                  |
| 121.60              | 1.747              | 0.347                  | 122.62              | 1.955              | 2.220                  |
| 121.62              | 1.749              | 0.382                  | 122.64              | 1.960              | 2.259                  |
| 121.64              | 1.752              | 0.417                  | 122.66              | 1.965              | 2.298                  |
| 121.66              | 1.755              | 0.452                  | 122.68              | 1.970              | 2.338                  |
| 121.68              | 1.757              | 0.487                  | 122.70              | 1.975              | 2.377                  |
| 121.70              | 1.760              | 0.522                  | 122.72              | 1.980              | 2.417                  |
| 121.72              | 1.763              | 0.557                  | 122.74              | 1.985              | 2.456                  |
| 121.74              | 1.765              | 0.593                  | 122.76              | 1.990              | 2.496                  |
| 121.76              | 1.768              | 0.628                  | 122.78              | 1.995              | 2.536                  |
| 121.78              | 1.771              | 0.663                  | 122.80              | 2.000              | 2.576                  |
| 121.80              | 1.773              | 0.699                  | 122.82              | 2.005              | 2.616                  |
| 121.82              | 1.776              | 0.734                  | 122.84              | 2.010              | 2.656                  |
| 121.84              | 1.779              | 0.770                  | 122.86              | 2.015              | 2.696                  |
| 121.86              | 1.781              | 0.805                  | 122.88              | 2.020              | 2.737                  |
| 121.88              | 1.784              | 0.841                  | 122.90              | 2.025              | 2.777                  |
| 121.90              | 1.787              | 0.877                  | 122.92              | 2.030              | 2.818                  |
| 121.92              | 1.789              | 0.912                  | 122.94              | 2.035              | 2.858                  |
| 121.94              | 1.792              | 0.948                  | 122.96              | 2.040              | 2.899                  |
| 121.96              | 1.795              | 0.984                  | 122.98              | 2.045              | 2.940                  |
| 121.98              | 1.797              | 1.020                  | 123.00              | <b>2.050</b>       | <b>2.981</b>           |
| 122.00              | 1.800              | 1.056                  |                     |                    |                        |
| 122.02              | 1.805              | 1.092                  |                     |                    |                        |
| 122.04              | 1.810              | 1.128                  |                     |                    |                        |
| 122.06              | 1.815              | 1.164                  |                     |                    |                        |
| 122.08              | 1.820              | 1.201                  |                     |                    |                        |
| 122.10              | 1.825              | 1.237                  |                     |                    |                        |
| 122.12              | 1.830              | 1.274                  |                     |                    |                        |
| 122.14              | 1.835              | 1.310                  |                     |                    |                        |
| 122.16              | 1.840              | 1.347                  |                     |                    |                        |
| 122.18              | 1.845              | 1.384                  |                     |                    |                        |
| 122.20              | 1.850              | 1.421                  |                     |                    |                        |
| 122.22              | 1.855              | 1.458                  |                     |                    |                        |
| 122.24              | 1.860              | 1.495                  |                     |                    |                        |
| 122.26              | 1.865              | 1.532                  |                     |                    |                        |
| 122.28              | 1.870              | 1.570                  |                     |                    |                        |
| 122.30              | 1.875              | 1.607                  |                     |                    |                        |
| 122.32              | 1.880              | 1.645                  |                     |                    |                        |
| 122.34              | 1.885              | 1.682                  |                     |                    |                        |
| 122.36              | 1.890              | 1.720                  |                     |                    |                        |
| 122.38              | 1.895              | 1.758                  |                     |                    |                        |
| 122.40              | 1.900              | 1.796                  |                     |                    |                        |

**206327HC003A**

Prepared by Beals & Thomas Inc

HydroCAD® 10.20-3c s/n 04493 © 2023 HydroCAD Software Solutions LLC

**Summary for Pond 200P: P-SUBSURFACE-2**

Inflow Area = 1.027 ac, 72.64% Impervious, Inflow Depth = 6.10" for 100-Year event  
Inflow = 4.94 cfs @ 12.15 hrs, Volume= 0.522 af  
Outflow = 1.60 cfs @ 12.47 hrs, Volume= 0.521 af, Atten= 68%, Lag= 19.2 min  
Primary = 1.60 cfs @ 12.47 hrs, Volume= 0.521 af  
Routed to Reach 200R : DP-2

Routing by Stor-Ind method, Time Span= 0.00-36.00 hrs, dt= 0.05 hrs  
Starting Elev= 120.30' Surf.Area= 0.053 ac Storage= 0.023 af  
Peak Elev= 123.78' @ 12.47 hrs Surf.Area= 0.053 ac Storage= 0.186 af (0.163 af above start)

Plug-Flow detention time= 176.3 min calculated for 0.497 af (95% of inflow)  
Center-of-Mass det. time= 121.2 min ( 913.7 - 792.5 )

| Volume | Invert  | Avail.Storage | Storage Description  |
|--------|---------|---------------|--|
| #1A    | 119.80' | 0.000 af      | <b>38.75"W x 59.50'L x 4.50'H Field A</b><br>0.238 af Overall - 0.238 af Embedded = 0.000 af x 40.0% Voids   |
| #2A    | 119.80' | 0.187 af      | <b>StormTrap ST2 SingleTrap 4-0 x 9 Inside #1</b><br>Inside= 101.7"W x 48.0"H => 30.55 sf x 15.40'L = 470.3 cf<br>Outside= 101.7"W x 54.0"H => 38.16 sf x 15.40'L = 587.4 cf<br>9 Chambers in 3 Rows<br>25.44' x 46.19' Core + 6.66' Border = 38.75' x 59.50' System |
|        |         | 0.187 af      | Total Available Storage  |

Storage Group A created with Chamber Wizard

| Device | Routing  | Invert  | Outlet Devices   |
|--------|----------|---------|--|
| #1     | Primary  | 120.30' | <b>12.0" Round Culvert</b><br>L= 15.0' CPP, square edge headwall, Ke= 0.500<br>Inlet / Outlet Invert= 120.30' / 120.00' S= 0.0200 '/' Cc= 0.900<br>n= 0.013 Corrugated PE, smooth interior, Flow Area= 0.79 sf |
| #2     | Device 1 | 120.30' | <b>3.0" Vert. Orifice/Grate</b> C= 0.600 Limited to weir flow at low heads   |
| #3     | Device 1 | 122.00' | <b>6.0" Vert. Orifice/Grate</b> C= 0.600 Limited to weir flow at low heads   |
| #4     | Primary  | 124.00' | <b>4.0' long x 2.00' rise Sharp-Crested Rectangular Weir</b><br>0 End Contraction(s) 4.2' Crest Height   |

**Primary OutFlow** Max=1.60 cfs @ 12.47 hrs HW=123.78' (Free Discharge)

- 1=Culvert (Passes 1.60 cfs of 6.53 cfs potential flow)
- 2=Orifice/Grate (Orifice Controls 0.43 cfs @ 8.82 fps)
- 3=Orifice/Grate (Orifice Controls 1.17 cfs @ 5.96 fps)
- 4=Sharp-Crested Rectangular Weir ( Controls 0.00 cfs)

**206327HC003A**

Prepared by Beals & Thomas Inc

HydroCAD® 10.20-3c s/n 04493 © 2023 HydroCAD Software Solutions LLC

**Pond 200P: P-SUBSURFACE-2 - Chamber Wizard Field A**

**Chamber Model = StormTrap ST2 SingleTrap 4-0 (StormTrap ST2 SingleTrap® Type II+IV)**

Inside= 101.7"W x 48.0"H => 30.55 sf x 15.40'L = 470.3 cf

Outside= 101.7"W x 54.0"H => 38.16 sf x 15.40'L = 587.4 cf

3 Chambers/Row x 15.40' Long = 46.19' Row Length +79.9" Border x 2 = 59.50' Base Length

3 Rows x 101.7" Wide + 79.9" Side Border x 2 = 38.75' Base Width

54.0" Chamber Height = 4.50' Field Height

9 Chambers x 470.3 cf + 3,910.4 cf Border = 8,142.8 cf Chamber Storage

9 Chambers x 587.4 cf + 5,088.3 cf Border = 10,375.3 cf Displacement

Chamber Storage = 8,142.8 cf = 0.187 af

Overall Storage Efficiency = 78.5%

Overall System Size = 59.50' x 38.75' x 4.50'

9 Chambers (plus border)

384.3 cy Field

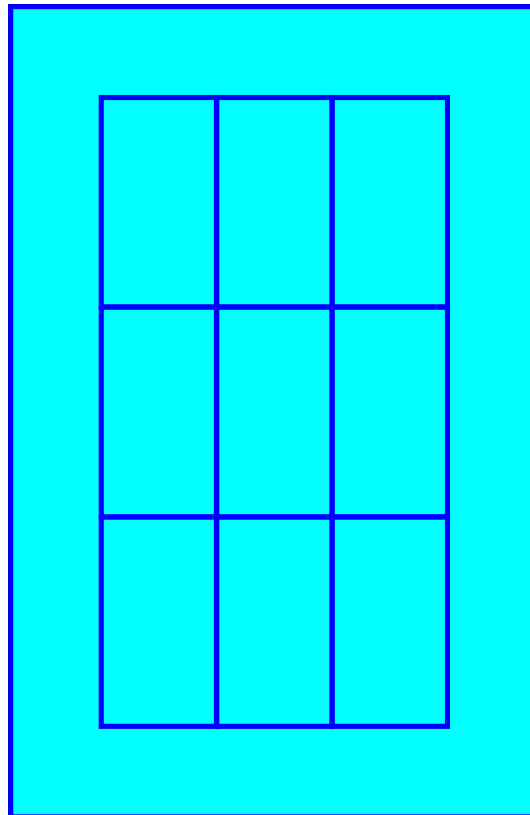

Pond 200P: P-SUBSURFACE-2

Hydrograph

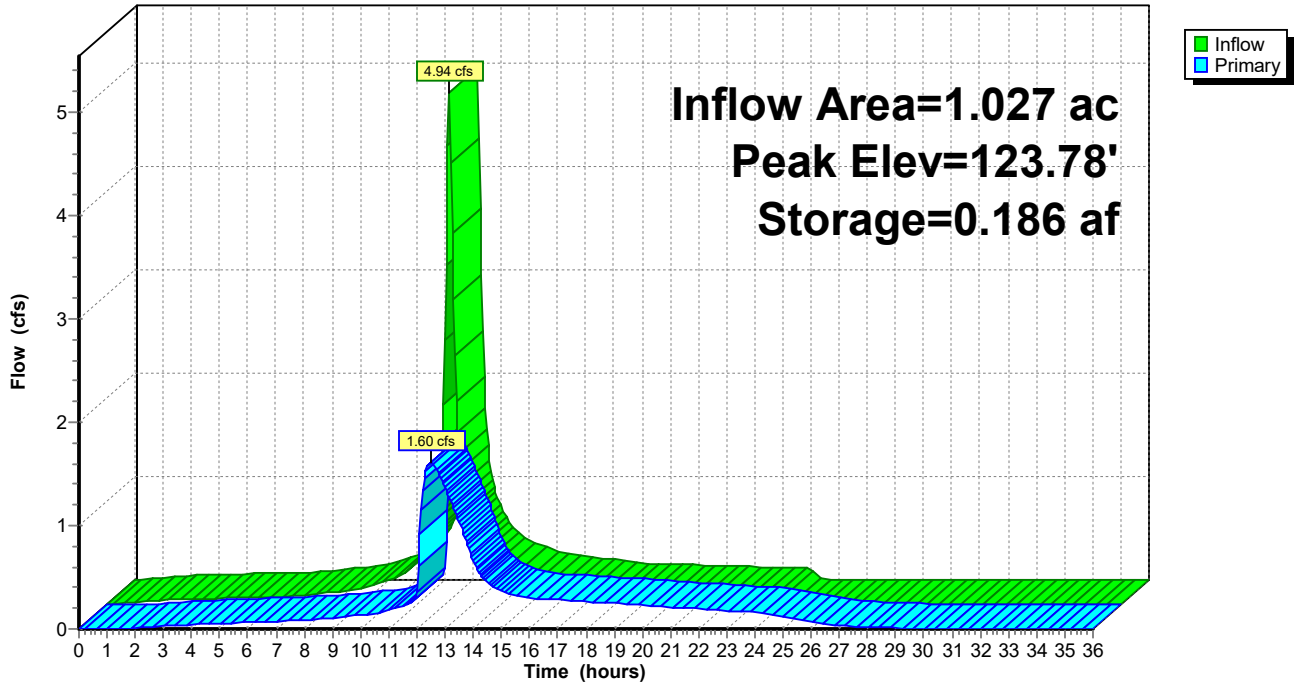

**206327HC003A**

Prepared by Beals & Thomas Inc

HydroCAD® 10.20-3c s/n 04493 © 2023 HydroCAD Software Solutions LLC

2063.27 Post-Development  
NRCC 24-hr D 100-Year Rainfall=8.36"

Printed 8/22/2023

Page 42

**Stage-Area-Storage for Pond 200P: P-SUBSURFACE-2**

| Elevation<br>(feet) | Storage<br>(acre-feet) | Elevation<br>(feet) | Storage<br>(acre-feet) | Elevation<br>(feet) | Storage<br>(acre-feet) |
|---------------------|------------------------|---------------------|------------------------|---------------------|------------------------|
| 119.80              | 0.000                  | 122.35              | 0.119                  | 124.90              | 0.187                  |
| 119.85              | 0.002                  | 122.40              | 0.122                  | 124.95              | 0.187                  |
| 119.90              | 0.005                  | 122.45              | 0.124                  | 125.00              | 0.187                  |
| 119.95              | 0.007                  | 122.50              | 0.126                  | 125.05              | 0.187                  |
| 120.00              | 0.009                  | 122.55              | 0.129                  | 125.10              | 0.187                  |
| 120.05              | 0.012                  | 122.60              | 0.131                  | 125.15              | 0.187                  |
| 120.10              | 0.014                  | 122.65              | 0.133                  | 125.20              | 0.187                  |
| 120.15              | 0.016                  | 122.70              | 0.136                  | 125.25              | 0.187                  |
| 120.20              | 0.019                  | 122.75              | 0.138                  | 125.30              | 0.187                  |
| 120.25              | 0.021                  | 122.80              | 0.140                  | 125.35              | 0.187                  |
| <b>120.30</b>       | <b>0.023</b>           | 122.85              | 0.143                  | 125.40              | 0.187                  |
| 120.35              | 0.026                  | 122.90              | 0.145                  | 125.45              | 0.187                  |
| 120.40              | 0.028                  | 122.95              | 0.147                  | 125.50              | 0.187                  |
| 120.45              | 0.030                  | 123.00              | 0.150                  | 125.55              | 0.187                  |
| 120.50              | 0.033                  | 123.05              | 0.152                  | 125.60              | 0.187                  |
| 120.55              | 0.035                  | 123.10              | 0.154                  | 125.65              | 0.187                  |
| 120.60              | 0.037                  | 123.15              | 0.157                  | 125.70              | 0.187                  |
| 120.65              | 0.040                  | 123.20              | 0.159                  | 125.75              | 0.187                  |
| 120.70              | 0.042                  | 123.25              | 0.161                  | 125.80              | 0.187                  |
| 120.75              | 0.044                  | 123.30              | 0.164                  | 125.85              | 0.187                  |
| 120.80              | 0.047                  | 123.35              | 0.166                  | 125.90              | 0.187                  |
| 120.85              | 0.049                  | 123.40              | 0.168                  | 125.95              | 0.187                  |
| 120.90              | 0.051                  | 123.45              | 0.171                  | 126.00              | 0.187                  |
| 120.95              | 0.054                  | 123.50              | 0.173                  |                     |                        |
| 121.00              | 0.056                  | 123.55              | 0.175                  |                     |                        |
| 121.05              | 0.058                  | 123.60              | 0.178                  |                     |                        |
| 121.10              | 0.061                  | 123.65              | 0.180                  |                     |                        |
| 121.15              | 0.063                  | 123.70              | 0.182                  |                     |                        |
| 121.20              | 0.065                  | 123.75              | 0.185                  |                     |                        |
| 121.25              | 0.068                  | 123.80              | 0.187                  |                     |                        |
| 121.30              | 0.070                  | 123.85              | 0.187                  |                     |                        |
| 121.35              | 0.072                  | 123.90              | 0.187                  |                     |                        |
| 121.40              | 0.075                  | 123.95              | 0.187                  |                     |                        |
| 121.45              | 0.077                  | 124.00              | 0.187                  |                     |                        |
| 121.50              | 0.079                  | 124.05              | 0.187                  |                     |                        |
| 121.55              | 0.082                  | 124.10              | 0.187                  |                     |                        |
| 121.60              | 0.084                  | 124.15              | 0.187                  |                     |                        |
| 121.65              | 0.086                  | 124.20              | 0.187                  |                     |                        |
| 121.70              | 0.089                  | 124.25              | <b>0.187</b>           |                     |                        |
| 121.75              | 0.091                  | 124.30              | <b>0.187</b>           |                     |                        |
| 121.80              | 0.093                  | 124.35              | 0.187                  |                     |                        |
| 121.85              | 0.096                  | 124.40              | 0.187                  |                     |                        |
| 121.90              | 0.098                  | 124.45              | 0.187                  |                     |                        |
| 121.95              | 0.100                  | 124.50              | 0.187                  |                     |                        |
| 122.00              | 0.103                  | 124.55              | 0.187                  |                     |                        |
| 122.05              | 0.105                  | 124.60              | 0.187                  |                     |                        |
| 122.10              | 0.107                  | 124.65              | 0.187                  |                     |                        |
| 122.15              | 0.110                  | 124.70              | 0.187                  |                     |                        |
| 122.20              | 0.112                  | 124.75              | 0.187                  |                     |                        |
| 122.25              | 0.114                  | 124.80              | 0.187                  |                     |                        |
| 122.30              | 0.117                  | 124.85              | 0.187                  |                     |                        |

**206327HC003A**

Prepared by Beals &amp; Thomas Inc

HydroCAD® 10.20-3c s/n 04493 © 2023 HydroCAD Software Solutions LLC

2063.27 Post-Development  
NRCC 24-hr D 100-Year Rainfall=8.36"

Printed 8/22/2023

Page 43

**Summary for Pond 300P: P-SUBSURFACE-3**

Inflow Area = 0.370 ac, 83.79% Impervious, Inflow Depth = 6.92" for 100-Year event  
 Inflow = 2.55 cfs @ 12.13 hrs, Volume= 0.213 af  
 Outflow = 1.92 cfs @ 12.19 hrs, Volume= 0.213 af, Atten= 24%, Lag= 3.7 min  
 Primary = 1.92 cfs @ 12.19 hrs, Volume= 0.213 af  
 Routed to Reach 300R : DP-3

Routing by Stor-Ind method, Time Span= 0.00-36.00 hrs, dt= 0.05 hrs  
 Starting Elev= 120.25' Surf.Area= 0.012 ac Storage= 0.001 af  
 Peak Elev= 123.29' @ 12.19 hrs Surf.Area= 0.012 ac Storage= 0.023 af (0.022 af above start)

Plug-Flow detention time= 17.5 min calculated for 0.212 af (99% of inflow)  
 Center-of-Mass det. time= 10.1 min ( 800.6 - 790.5 )

| Volume | Invert  | Avail.Storage | Storage Description  |
|--------|---------|---------------|--|
| #1A    | 120.00' | 0.011 af      | <b>20.50'W x 24.98'L x 3.50'H Field A</b><br>0.041 af Overall - 0.013 af Embedded = 0.028 af x 40.0% Voids   |
| #2A    | 120.50' | 0.013 af      | <b>ADS_StormTech SC-740 +Cap</b> x 12 Inside #1<br>Effective Size= 44.6"W x 30.0"H => 6.45 sf x 7.12'L = 45.9 cf<br>Overall Size= 51.0"W x 30.0"H x 7.56'L with 0.44' Overlap<br>12 Chambers in 4 Rows |
|        |         | 0.024 af      | Total Available Storage  |

Storage Group A created with Chamber Wizard

| Device | Routing  | Invert  | Outlet Devices   |
|--------|----------|---------|--|
| #1     | Primary  | 120.00' | <b>12.0" Round Culvert</b><br>L= 25.0' CPP, square edge headwall, Ke= 0.500<br>Inlet / Outlet Invert= 120.00' / 119.50' S= 0.0200 '/' Cc= 0.900<br>n= 0.013 Corrugated PE, smooth interior, Flow Area= 0.79 sf |
| #2     | Device 1 | 120.25' | <b>4.0" Vert. Orifice/Grate</b> C= 0.600 Limited to weir flow at low heads   |
| #3     | Device 1 | 121.40' | <b>6.0" Vert. Orifice/Grate</b> C= 0.600 Limited to weir flow at low heads   |
| #4     | Device 1 | 123.30' | <b>4.0' long x 1.70' rise Sharp-Crested Rectangular Weir</b><br>2 End Contraction(s) 3.3' Crest Height   |

**Primary OutFlow** Max=1.90 cfs @ 12.19 hrs HW=123.24' (Free Discharge)

- ↑ **1=Culvert** (Passes 1.90 cfs of 6.27 cfs potential flow)
- ↑ **2=Orifice/Grate** (Orifice Controls 0.71 cfs @ 8.10 fps)
- ↑ **3=Orifice/Grate** (Orifice Controls 1.19 cfs @ 6.08 fps)
- ↑ **4=Sharp-Crested Rectangular Weir** ( Controls 0.00 cfs)

**206327HC003A**

Prepared by Beals & Thomas Inc

HydroCAD® 10.20-3c s/n 04493 © 2023 HydroCAD Software Solutions LLC

**Pond 300P: P-SUBSURFACE-3 - Chamber Wizard Field A**

**Chamber Model = ADS\_StormTech SC-740 +Cap (ADS StormTech® SC-740 with cap length)**

Effective Size= 44.6"W x 30.0"H => 6.45 sf x 7.12'L = 45.9 cf

Overall Size= 51.0"W x 30.0"H x 7.56'L with 0.44' Overlap

51.0" Wide + 6.0" Spacing = 57.0" C-C Row Spacing

3 Chambers/Row x 7.12' Long +0.81' Cap Length x 2 = 22.98' Row Length +12.0" End Stone x 2 = 24.98' Base Length

4 Rows x 51.0" Wide + 6.0" Spacing x 3 + 12.0" Side Stone x 2 = 20.50' Base Width

6.0" Stone Base + 30.0" Chamber Height + 6.0" Stone Cover = 3.50' Field Height

12 Chambers x 45.9 cf = 551.3 cf Chamber Storage

1,792.1 cf Field - 551.3 cf Chambers = 1,240.8 cf Stone x 40.0% Voids = 496.3 cf Stone Storage

Chamber Storage + Stone Storage = 1,047.6 cf = 0.024 af

Overall Storage Efficiency = 58.5%

Overall System Size = 24.98' x 20.50' x 3.50'

12 Chambers

66.4 cy Field

46.0 cy Stone

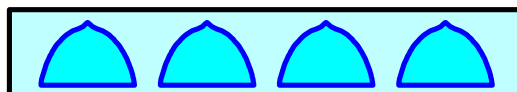
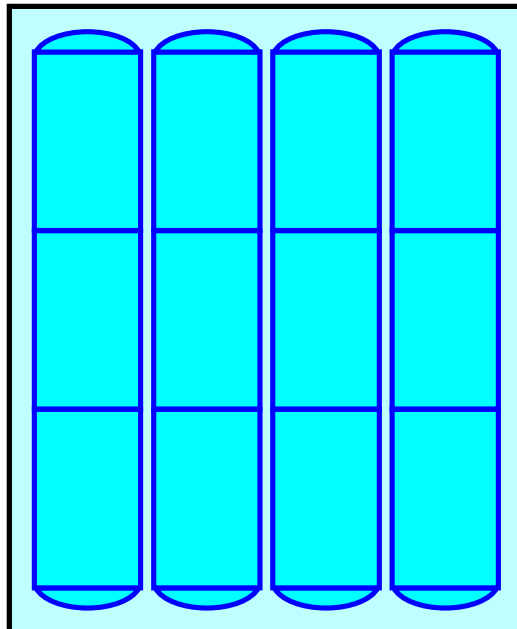

### Pond 300P: P-SUBSURFACE-3

Hydrograph

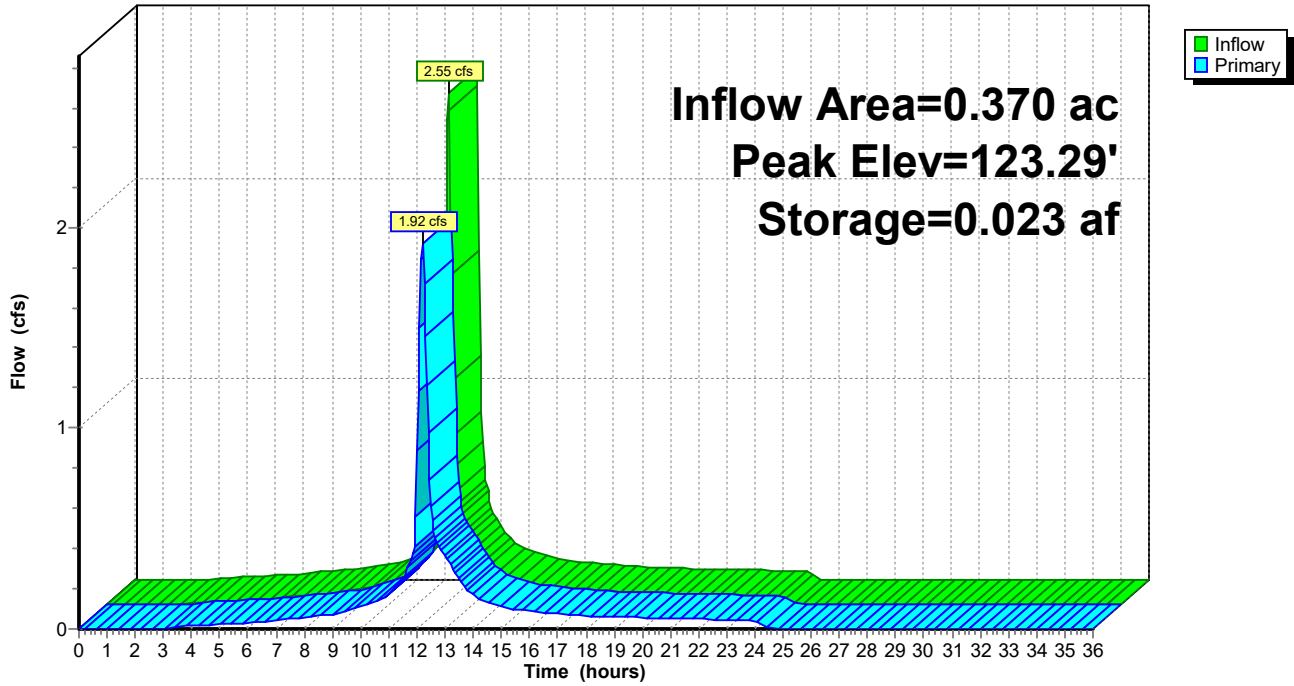

**206327HC003A**

Prepared by Beals &amp; Thomas Inc

HydroCAD® 10.20-3c s/n 04493 © 2023 HydroCAD Software Solutions LLC

2063.27 Post-Development

NRCC 24-hr D 100-Year Rainfall=8.36"

Printed 8/22/2023

Page 46

**Stage-Area-Storage for Pond 300P: P-SUBSURFACE-3**

| Elevation<br>(feet) | Storage<br>(acre-feet) | Elevation<br>(feet) | Storage<br>(acre-feet) |
|---------------------|------------------------|---------------------|------------------------|
| 120.00              | 0.000                  | 122.55              | 0.019                  |
| 120.05              | 0.000                  | 122.60              | 0.020                  |
| 120.10              | 0.000                  | 122.65              | 0.020                  |
| 120.15              | 0.001                  | 122.70              | 0.020                  |
| 120.20              | 0.001                  | 122.75              | 0.020                  |
| <b>120.25</b>       | <b>0.001</b>           | 122.80              | 0.021                  |
| 120.30              | 0.001                  | 122.85              | 0.021                  |
| 120.35              | 0.002                  | 122.90              | 0.021                  |
| 120.40              | 0.002                  | 122.95              | 0.021                  |
| 120.45              | 0.002                  | 123.00              | 0.022                  |
| 120.50              | 0.002                  | 123.05              | 0.022                  |
| 120.55              | 0.003                  | 123.10              | 0.022                  |
| 120.60              | 0.003                  | 123.15              | 0.022                  |
| 120.65              | 0.004                  | 123.20              | 0.023                  |
| 120.70              | 0.004                  | 123.25              | 0.023                  |
| 120.75              | 0.005                  | 123.30              | 0.023                  |
| 120.80              | 0.005                  | 123.35              | 0.023                  |
| 120.85              | 0.006                  | 123.40              | 0.024                  |
| 120.90              | 0.006                  | 123.45              | 0.024                  |
| 120.95              | 0.006                  | 123.50              | <b>0.024</b>           |
| 121.00              | 0.007                  | 123.55              | 0.024                  |
| 121.05              | 0.007                  | 123.60              | 0.024                  |
| 121.10              | 0.008                  | 123.65              | 0.024                  |
| 121.15              | 0.008                  | 123.70              | 0.024                  |
| 121.20              | 0.009                  | 123.75              | 0.024                  |
| 121.25              | 0.009                  | 123.80              | 0.024                  |
| 121.30              | 0.009                  | 123.85              | 0.024                  |
| 121.35              | 0.010                  | 123.90              | 0.024                  |
| 121.40              | 0.010                  | 123.95              | 0.024                  |
| 121.45              | 0.011                  | 124.00              | 0.024                  |
| 121.50              | 0.011                  | 124.05              | 0.024                  |
| 121.55              | 0.012                  | 124.10              | 0.024                  |
| 121.60              | 0.012                  | 124.15              | 0.024                  |
| 121.65              | 0.012                  | 124.20              | 0.024                  |
| 121.70              | 0.013                  | 124.25              | 0.024                  |
| 121.75              | 0.013                  | 124.30              | 0.024                  |
| 121.80              | 0.014                  | 124.35              | 0.024                  |
| 121.85              | 0.014                  | 124.40              | 0.024                  |
| 121.90              | 0.014                  | 124.45              | 0.024                  |
| 121.95              | 0.015                  | 124.50              | 0.024                  |
| 122.00              | 0.015                  | 124.55              | 0.024                  |
| 122.05              | 0.016                  | 124.60              | 0.024                  |
| 122.10              | 0.016                  | 124.65              | 0.024                  |
| 122.15              | 0.016                  | 124.70              | 0.024                  |
| 122.20              | 0.017                  | 124.75              | 0.024                  |
| 122.25              | 0.017                  | 124.80              | 0.024                  |
| 122.30              | 0.017                  | 124.85              | 0.024                  |
| 122.35              | 0.018                  | 124.90              | 0.024                  |
| 122.40              | 0.018                  | 124.95              | 0.024                  |
| 122.45              | 0.019                  | 125.00              | 0.024                  |
| 122.50              | 0.019                  |                     |                        |

**Attachment 4**  
**Floodplain & Proposed Compensatory Storage Analysis**

---

## 2063.27 Floodplain & Proposed Compensatory Storage

### Objective

To determine the 100-year floodplain volume lost given the proposed grading design and design adequate compensatory storage volumes. Also, to demonstrate proposed stormwater systems will have adequate volume to mitigate for the increase in total runoff volumes generated during the 100-year storm event.

### Conclusion

The operative, proposed grading results in a net loss of approximately 810± cubic yards of flood storage between elevation 119.0 and 124.7. A compensatory storage volume (consisting of StormTrap ST2 Single-Trap 4-0 & 4-6 chambers) provides approximately 1,084± cubic yards of total compensatory storage.

Note, surplus compensatory storage is proposed at lower elevations due to proposed site constraints (i.e. foot-for-foot compensation not possible between 123.0 and 124.7 with the current design). The surplus at lower elevations will ensure that there will not be a deficit in compensation as the flood level rises. Total floodplain volume is increased in the post-development condition.

Regarding stormwater, the increase in total site runoff during the 100-year storm event will be mitigated by the available surplus within the dedicated floodplain compensatory storage and the effective storage within Subsurface Stormwater Systems #2 & #3 (i.e. between lowest outlets and floodplain elevation of 124.7):

|                       |          |  |
|-----------------------|----------|--|
| 1.226 af - 0.879 af = | 0.347 af | Increase in total site runoff volume during 100-year storm |
| 275 cy =              | 0.170 af | Available surplus within dedicated compensatory storage    |
| 0.187 af - 0.023 af = | 0.164 af | Subsurface Stormwater System #2 effective storage volume   |
| 0.024 af - 0.001 af = | 0.023 af | Subsurface Stormwater System #3 effective storage volume   |

$$(0.170 \text{ af} + 0.164 \text{ af} + 0.023 \text{ af}) - 0.347 \text{ af} = 0.010 \text{ af} = 435 \pm \text{ cf} = 16 \pm \text{ cy surplus}$$

### Calculation Methods

1. Analysis of flood volumes between existing/proposed surfaces and incremental flood elevations performed with Trimble Paydirt SiteWork (version 5.23) earthworks software.
2. Subsurface chamber compensatory storage volumes modeled with HydroCAD (version 10.20-2g) hydrology software.
3. Existing and proposed surface information exported from AutoCAD Civil 3D.
4. Hydrologic calculations from HydroCAD.

### Assumptions

1. Stormwater tailwater effects were not analyzed.
2. Proposed compensatory storage is free draining.
3. Proposed compensatory storage volumes will not be influenced by groundwater.
4. Proposed stone void volumes were not included in the analyses.

- Infiltration at the subsurface floodplain compensation system and Subsurface Stormwater Systems #2 & #3 was conservatively not modelled.

**Sources of Data/ Equations**

- Existing topography from B+T base file 206326B017C.
- Proposed surface from B+T design file 206327D032A.
- Paydirt file no. 206327PD001A.
- Excerpts from pre & post-development hydrologic models (HCAD files 206327HC002A & 206327HC003A) for "Design Point 6" reach DP-6 and Proposed Subsurface Stormwater Systems #2 & #3.
- Pre and Post-Development Calculation Summaries (206327CS002A & 206327CS003A) for additional information regarding overall site hydrology.

**List of Attachments**

- Floodplain Storage Volume Tabulation
- Paydirt Earthwork Volume Maps and Reports
- Compensatory Floodplain Storage System Models
- Subsurface Stormwater Storage System Models

| REV | CALC. BY | DATE | CHECKED BY | DATE | APPROVED BY | DATE |
|-----|----------|------|------------|------|-------------|------|
| 0   |          |      |            |      |             |      |
|     |          |      |            |      |             |      |
|     |          |      |            |      |             |      |

206327CS001A

## **Attachment 1**

---

### Floodplain Storage Volume Tabulation

| Elevation | Floodplain Storage Volumes (Cubic Yards) |            |               |            |             |            |                       |            |                  |            |
|-----------|--|------------|---------------|------------|-------------|------------|-----------------------|------------|------------------|------------|
|           | From Existing                            |            | From Proposed |            | Delta       |            | Proposed Compensation |            | Proposed Surplus |            |
|           | Incremental                              | Cumulative | Incremental   | Cumulative | Incremental | Cumulative | Incremental           | Cumulative | Incremental      | Cumulative |
| 119.0     | 0  | 0          | 0             | 0          | 0           | 0          | 0                     | 0          | 0                | 0          |
| 120.0     | 39                                       | 39         | 1             | 1          | -38         | -38        | 51                    | 51         | 13               | 13         |
| 121.0     | 65                                       | 104        | 6             | 7          | -59         | -97        | 254                   | 305        | 195              | 208        |
| 122.0     | 84                                       | 188        | 13            | 20         | -71         | -168       | 254                   | 559        | 183              | 391        |
| 123.0     | 154                                      | 342        | 26            | 46         | -128        | -296       | 255                   | 814        | 127              | 518        |
| 124.0     | 418                                      | 760        | 91            | 137        | -327        | -623       | 230                   | 1,044      | -97              | 421        |
| 124.7     | 844                                      | 1,604      | 658           | 795        | -186        | -809       | 40                    | 1,084      | -146             | 275        |

## **Attachment 2**

---

### **Paydirt Earthwork Volume Maps and Reports** (Comparing Existing and Proposed Topography to the Respective Floodplain Elevations)

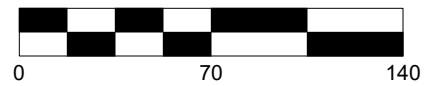
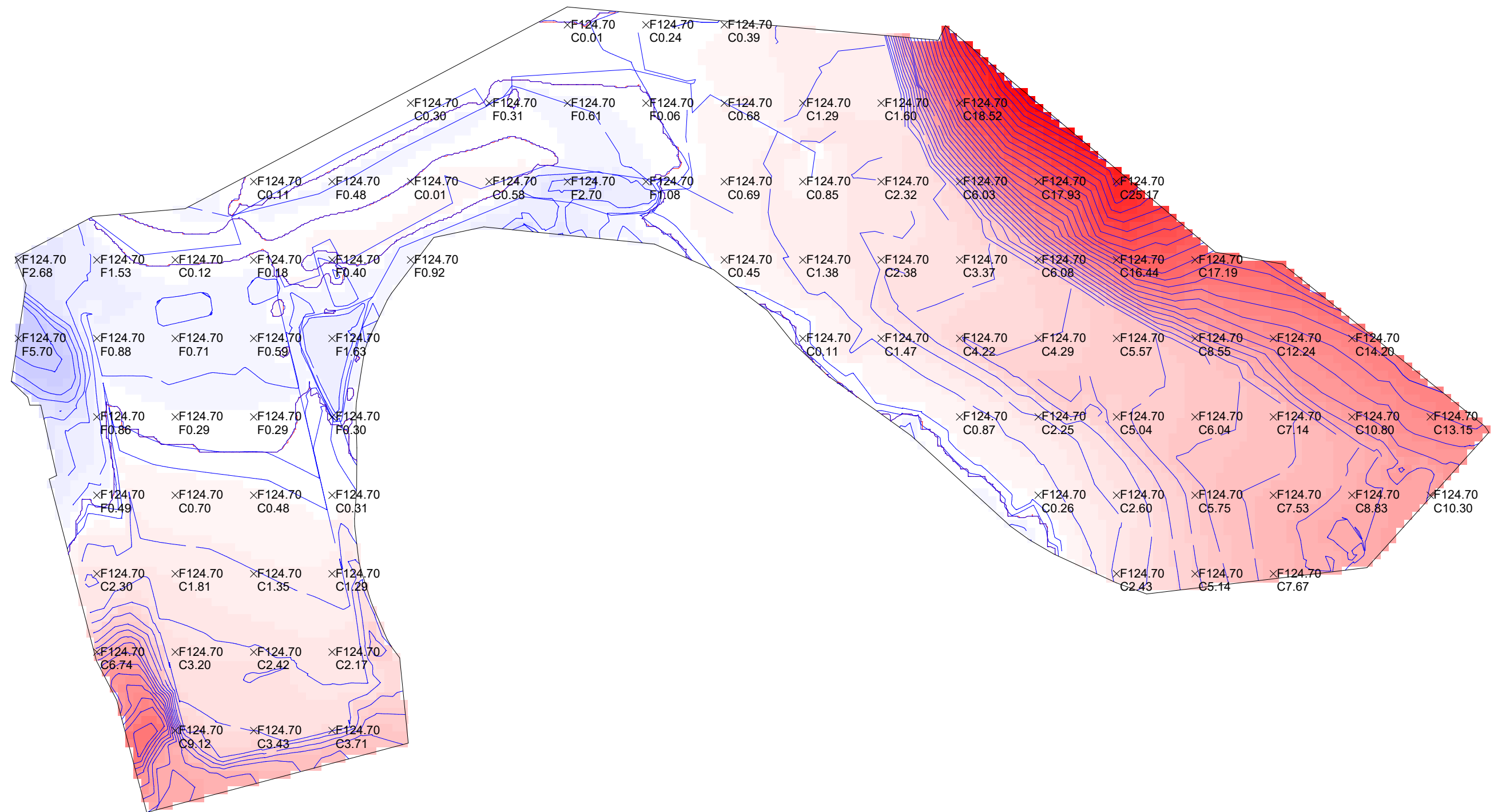
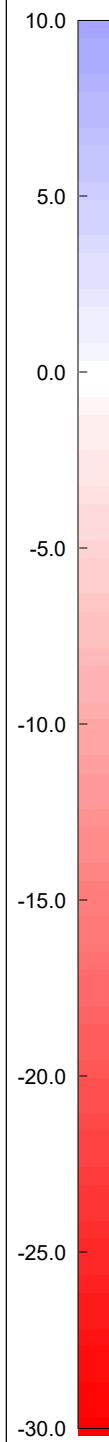

**Cut/Fill Locations Report**  
 206327PD001A: Flood Plain Calculation  
 206327PD001A  
 Existing vs. Floodplain EL=124.7  
 July 29, 2023 · 10:31 PM

| Area of Interest<br>Cut/Fill Zone  | Area<br>(sq ft)  | Average<br>Depth<br>(ft) | Maximum<br>Depth<br>(ft) | Bank<br>Volume<br>(cu yd) | Shrink<br>Swell<br>(%) | Adjusted<br>Volume<br>(cu yd) | Center of Mass |         |
|------------------------------------|------------------|--------------------------|--------------------------|---------------------------|------------------------|-------------------------------|----------------|---------|
|                                    |                  |                          |                          |                           |                        |                               | X              | Y       |
| <b>LOW</b>                         |                  |                          |                          |                           |                        |                               |                |         |
| Cut Zone 1                         | 205469.18        | 9.46                     | 35.00                    | 71979.05                  | 0.00                   | 71979.05                      | 5766.19        | 6390.23 |
| LOW: Total Cut                     | <b>205469.18</b> | <b>9.46</b>              | <b>35.00</b>             | <b>71979.05</b>           | <b>0.00</b>            | <b>71979.05</b>               | 0.00           | 0.00    |
| Misc. Fills (6)                    | 105.82           | 0.00                     | 0.00                     | 0.00                      | 0.00                   | 0.00                          | 0.00           | 0.00    |
| LOW: Total Fill                    | <b>105.82</b>    | <b>0.00</b>              | <b>0.00</b>              | <b>0.00</b>               | <b>0.00</b>            | <b>0.00</b>                   | 0.00           | 0.00    |
| <b>LOW: Import/Export</b>          |                  |                          | <b>Export</b>            | <b>71979.05</b>           | <b>Export</b>          | <b>71979.05</b>               |                |         |
| <b>206327PD001A</b>                |                  |                          |                          |                           |                        |                               |                |         |
| LOW: Total Cut                     | 205469.18        | 9.46                     | 35.00                    | 71979.05                  | 0.00                   | 71979.05                      | 0.00           | 0.00    |
| 206327PD001A: Total Cut            | <b>205469.18</b> | <b>9.46</b>              | <b>35.00</b>             | <b>71979.05</b>           | <b>0.00</b>            | <b>71979.05</b>               | 0.00           | 0.00    |
| LOW: Total Fill                    | 105.82           | 0.00                     | 0.00                     | 0.00                      | 0.00                   | 0.00                          | 0.00           | 0.00    |
| 206327PD001A: Total Fill           | <b>105.82</b>    | <b>0.00</b>              | <b>0.00</b>              | <b>0.00</b>               | <b>0.00</b>            | <b>0.00</b>                   | 0.00           | 0.00    |
| <b>206327PD001A: Import/Export</b> |                  |                          | <b>Export</b>            | <b>71979.05</b>           | <b>Export</b>          | <b>71979.05</b>               |                |         |

| Area of Interest<br>Cut/Fill Zone  | Area<br>(sq ft)  | Average<br>Depth<br>(ft) | Maximum<br>Depth<br>(ft) | Bank<br>Volume<br>(cu yd) | Shrink<br>Swell<br>(%) | Adjusted<br>Volume<br>(cu yd) | Center of Mass |         |
|------------------------------------|------------------|--------------------------|--------------------------|---------------------------|------------------------|-------------------------------|----------------|---------|
|                                    |                  |                          |                          |                           |                        |                               | X              | Y       |
| <b>LOW</b>                         |                  |                          |                          |                           |                        |                               |                |         |
| Cut Zone 1                         | 204117.05        | 8.52                     | 34.00                    | 64404.11                  | 0.00                   | 64404.11                      | 5776.90        | 6389.92 |
| LOW: Total Cut                     | <b>204117.05</b> | <b>8.52</b>              | <b>34.00</b>             | <b>64404.11</b>           | <b>0.00</b>            | <b>64404.11</b>               | 0.00           | 0.00    |
| Fill Zone 1                        | 1457.95          | 0.72                     | 1.00                     | 38.94                     | 0.00                   | 38.94                         | 5263.84        | 6392.26 |
| LOW: Total Fill                    | <b>1457.95</b>   | <b>0.72</b>              | <b>1.00</b>              | <b>38.94</b>              | <b>0.00</b>            | <b>38.94</b>                  | 0.00           | 0.00    |
| <b>LOW: Import/Export</b>          |                  |                          | <b>Export</b>            | <b>64365.17</b>           | <b>Export</b>          | <b>64365.17</b>               |                |         |
| <hr/>                              |                  |                          |                          |                           |                        |                               |                |         |
| <b>206327PD001A</b>                |                  |                          |                          |                           |                        |                               |                |         |
| LOW: Total Cut                     | 204117.05        | 8.52                     | 34.00                    | 64404.11                  | 0.00                   | 64404.11                      | 0.00           | 0.00    |
| 206327PD001A: Total Cut            | <b>204117.05</b> | <b>8.52</b>              | <b>34.00</b>             | <b>64404.11</b>           | <b>0.00</b>            | <b>64404.11</b>               | 0.00           | 0.00    |
| LOW: Total Fill                    | 1457.95          | 0.72                     | 1.00                     | 38.94                     | 0.00                   | 38.94                         | 0.00           | 0.00    |
| 206327PD001A: Total Fill           | <b>1457.95</b>   | <b>0.72</b>              | <b>1.00</b>              | <b>38.94</b>              | <b>0.00</b>            | <b>38.94</b>                  | 0.00           | 0.00    |
| <b>206327PD001A: Import/Export</b> |                  |                          | <b>Export</b>            | <b>64365.17</b>           | <b>Export</b>          | <b>64365.17</b>               |                |         |

| Area of Interest<br>Cut/Fill Zone  | Area<br>(sq ft)  | Average<br>Depth<br>(ft) | Maximum<br>Depth<br>(ft) | Bank<br>Volume<br>(cu yd) | Shrink<br>Swell<br>(%) | Adjusted<br>Volume<br>(cu yd) | Center of Mass |         |
|------------------------------------|------------------|--------------------------|--------------------------|---------------------------|------------------------|-------------------------------|----------------|---------|
|                                    |                  |                          |                          |                           |                        |                               | X              | Y       |
| <b>LOW</b>                         |                  |                          |                          |                           |                        |                               |                |         |
| Cut Zone 1                         | 203573.02        | 7.54                     | 33.00                    | 56854.27                  | 0.00                   | 56854.27                      | 5790.24        | 6389.52 |
| LOW: Total Cut                     | <b>203573.02</b> | <b>7.54</b>              | <b>33.00</b>             | <b>56854.27</b>           | <b>0.00</b>            | <b>56854.27</b>               | 0.00           | 0.00    |
| Fill Zone 1                        | 1982.62          | 1.40                     | 2.00                     | 103.01                    | 0.00                   | 103.01                        | 5265.64        | 6389.99 |
| Misc. Fills (1)                    | 43.39            | 0.42                     | 0.42                     | 0.68                      | 0.00                   | 0.68                          | 0.00           | 0.00    |
| LOW: Total Fill                    | <b>2026.00</b>   | <b>1.38</b>              | <b>2.00</b>              | <b>103.69</b>             | <b>0.00</b>            | <b>103.69</b>                 | 0.00           | 0.00    |
| <b>LOW: Import/Export</b>          |                  |                          | <b>Export</b>            | <b>56750.58</b>           | <b>Export</b>          | <b>56750.58</b>               |                |         |
| <hr/>                              |                  |                          |                          |                           |                        |                               |                |         |
| <b>206327PD001A</b>                |                  |                          |                          |                           |                        |                               |                |         |
| LOW: Total Cut                     | 203573.02        | 7.54                     | 33.00                    | 56854.27                  | 0.00                   | 56854.27                      | 0.00           | 0.00    |
| 206327PD001A: Total Cut            | <b>203573.02</b> | <b>7.54</b>              | <b>33.00</b>             | <b>56854.27</b>           | <b>0.00</b>            | <b>56854.27</b>               | 0.00           | 0.00    |
| LOW: Total Fill                    | 2026.00          | 1.38                     | 2.00                     | 103.69                    | 0.00                   | 103.69                        | 0.00           | 0.00    |
| 206327PD001A: Total Fill           | <b>2026.00</b>   | <b>1.38</b>              | <b>2.00</b>              | <b>103.69</b>             | <b>0.00</b>            | <b>103.69</b>                 | 0.00           | 0.00    |
| <b>206327PD001A: Import/Export</b> |                  |                          | <b>Export</b>            | <b>56750.58</b>           | <b>Export</b>          | <b>56750.58</b>               |                |         |

| Area of Interest<br>Cut/Fill Zone  | Area<br>(sq ft)  | Average<br>Depth<br>(ft) | Maximum<br>Depth<br>(ft) | Bank<br>Volume<br>(cu yd) | Shrink<br>Swell<br>(%) | Adjusted<br>Volume<br>(cu yd) | Center of Mass |             |
|------------------------------------|------------------|--------------------------|--------------------------|---------------------------|------------------------|-------------------------------|----------------|-------------|
|                                    |                  |                          |                          |                           |                        |                               | X              | Y           |
| <b>LOW</b>                         |                  |                          |                          |                           |                        |                               |                |             |
| Cut Zone 1                         | 202877.44        | 6.56                     | 32.00                    | 49325.31                  | 0.00                   | 49325.31                      | 5807.44        | 6389.01     |
| Misc. Cuts (1)                     | 62.50            | 0.01                     | 0.01                     | 0.01                      | 0.00                   | 0.01                          | 0.00           | 0.00        |
| <b>LOW: Total Cut</b>              | <b>202939.94</b> | <b>6.56</b>              | <b>32.00</b>             | <b>49325.33</b>           | <b>0.00</b>            | <b>49325.33</b>               | <b>0.00</b>    | <b>0.00</b> |
| Fill Zone 1                        | 2581.29          | 1.96                     | 3.00                     | 187.58                    | 0.00                   | 187.58                        | 5266.91        | 6388.41     |
| Misc. Fills (5)                    | 87.11            | 0.10                     | 0.36                     | 0.32                      | 0.00                   | 0.32                          | 0.00           | 0.00        |
| <b>LOW: Total Fill</b>             | <b>2668.39</b>   | <b>1.90</b>              | <b>3.00</b>              | <b>187.90</b>             | <b>0.00</b>            | <b>187.90</b>                 | <b>0.00</b>    | <b>0.00</b> |
| <b>LOW: Import/Export</b>          |                  |                          | <b>Export</b>            | <b>49137.43</b>           | <b>Export</b>          | <b>49137.43</b>               |                |             |
| <hr/>                              |                  |                          |                          |                           |                        |                               |                |             |
| <b>206327PD001A</b>                |                  |                          |                          |                           |                        |                               |                |             |
| LOW: Total Cut                     | 202939.94        | 6.56                     | 32.00                    | 49325.33                  | 0.00                   | 49325.33                      | 0.00           | 0.00        |
| 206327PD001A: Total Cut            | <b>202939.94</b> | <b>6.56</b>              | <b>32.00</b>             | <b>49325.33</b>           | <b>0.00</b>            | <b>49325.33</b>               | <b>0.00</b>    | <b>0.00</b> |
| LOW: Total Fill                    | 2668.39          | 1.90                     | 3.00                     | 187.90                    | 0.00                   | 187.90                        | 0.00           | 0.00        |
| 206327PD001A: Total Fill           | <b>2668.39</b>   | <b>1.90</b>              | <b>3.00</b>              | <b>187.90</b>             | <b>0.00</b>            | <b>187.90</b>                 | <b>0.00</b>    | <b>0.00</b> |
| <b>206327PD001A: Import/Export</b> |                  |                          | <b>Export</b>            | <b>49137.43</b>           | <b>Export</b>          | <b>49137.43</b>               |                |             |

| Area of Interest<br>Cut/Fill Zone  | Area<br>(sq ft)  | Average<br>Depth<br>(ft) | Maximum<br>Depth<br>(ft) | Bank<br>Volume<br>(cu yd) | Shrink<br>Swell<br>(%) | Adjusted<br>Volume<br>(cu yd) | Center of Mass |             |
|------------------------------------|------------------|--------------------------|--------------------------|---------------------------|------------------------|-------------------------------|----------------|-------------|
|                                    |                  |                          |                          |                           |                        |                               | X              | Y           |
| <b>LOW</b>                         |                  |                          |                          |                           |                        |                               |                |             |
| Cut Zone 1                         | 199158.23        | 5.68                     | 31.00                    | 41865.56                  | 0.00                   | 41865.56                      | 5830.11        | 6388.38     |
| Misc. Cuts (1)                     | 24.14            | 0.00                     | 0.00                     | 0.00                      | 0.00                   | 0.00                          | 0.00           | 0.00        |
| <b>LOW: Total Cut</b>              | <b>199182.37</b> | <b>5.68</b>              | <b>31.00</b>             | <b>41865.56</b>           | <b>0.00</b>            | <b>41865.56</b>               | <b>0.00</b>    | <b>0.00</b> |
| Fill Zone 1                        | 4969.47          | 1.72                     | 4.00                     | 316.18                    | 0.00                   | 316.18                        | 5268.11        | 6389.98     |
| Misc. Fills (12)                   | 1467.60          | 0.48                     | 1.36                     | 25.89                     | 0.00                   | 25.89                         | 0.00           | 0.00        |
| <b>LOW: Total Fill</b>             | <b>6437.07</b>   | <b>1.43</b>              | <b>4.00</b>              | <b>342.06</b>             | <b>0.00</b>            | <b>342.06</b>                 | <b>0.00</b>    | <b>0.00</b> |
| <b>LOW: Import/Export</b>          |                  |                          | <b>Export</b>            | <b>41523.50</b>           | <b>Export</b>          | <b>41523.50</b>               |                |             |
| <hr/>                              |                  |                          |                          |                           |                        |                               |                |             |
| <b>206327PD001A</b>                |                  |                          |                          |                           |                        |                               |                |             |
| LOW: Total Cut                     | 199182.37        | 5.68                     | 31.00                    | 41865.56                  | 0.00                   | 41865.56                      | 0.00           | 0.00        |
| <b>206327PD001A: Total Cut</b>     | <b>199182.37</b> | <b>5.68</b>              | <b>31.00</b>             | <b>41865.56</b>           | <b>0.00</b>            | <b>41865.56</b>               | <b>0.00</b>    | <b>0.00</b> |
| LOW: Total Fill                    | 6437.07          | 1.43                     | 4.00                     | 342.06                    | 0.00                   | 342.06                        | 0.00           | 0.00        |
| <b>206327PD001A: Total Fill</b>    | <b>6437.07</b>   | <b>1.43</b>              | <b>4.00</b>              | <b>342.06</b>             | <b>0.00</b>            | <b>342.06</b>                 | <b>0.00</b>    | <b>0.00</b> |
| <b>206327PD001A: Import/Export</b> |                  |                          | <b>Export</b>            | <b>41523.50</b>           | <b>Export</b>          | <b>41523.50</b>               |                |             |

| Area of Interest<br>Cut/Fill Zone  | Area<br>(sq ft)  | Average<br>Depth<br>(ft) | Maximum<br>Depth<br>(ft) | Bank<br>Volume<br>(cu yd) | Shrink<br>Swell<br>(%) | Adjusted<br>Volume<br>(cu yd) | Center of Mass |             |
|------------------------------------|------------------|--------------------------|--------------------------|---------------------------|------------------------|-------------------------------|----------------|-------------|
|                                    |                  |                          |                          |                           |                        |                               | X              | Y           |
| <b>LOW</b>                         |                  |                          |                          |                           |                        |                               |                |             |
| Cut Zone 1                         | 186887.79        | 5.01                     | 30.00                    | 34665.86                  | 0.00                   | 34665.86                      | 5859.31        | 6387.79     |
| Misc. Cuts (8)                     | 462.20           | 0.23                     | 0.94                     | 3.86                      | 0.00                   | 3.86                          | 0.00           | 0.00        |
| <b>LOW: Total Cut</b>              | <b>187349.99</b> | <b>5.00</b>              | <b>30.00</b>             | <b>34669.73</b>           | <b>0.00</b>            | <b>34669.73</b>               | <b>0.00</b>    | <b>0.00</b> |
| Fill Zone 1                        | 10642.52         | 1.45                     | 5.00                     | 571.25                    | 0.00                   | 571.25                        | 5273.36        | 6392.78     |
| Fill Zone 2                        | 4954.61          | 0.74                     | 2.36                     | 135.71                    | 0.00                   | 135.71                        | 5599.24        | 6487.75     |
| Fill Zone 3                        | 2178.38          | 0.65                     | 1.00                     | 52.78                     | 0.00                   | 52.78                         | 5451.81        | 6395.57     |
| Misc. Fills (30)                   | 561.75           | 0.02                     | 0.14                     | 0.46                      | 0.00                   | 0.46                          | 0.00           | 0.00        |
| <b>LOW: Total Fill</b>             | <b>18337.27</b>  | <b>1.12</b>              | <b>5.00</b>              | <b>760.20</b>             | <b>0.00</b>            | <b>760.20</b>                 | <b>0.00</b>    | <b>0.00</b> |
| <b>LOW: Import/Export</b>          |                  |                          | <b>Export</b>            | <b>33909.53</b>           | <b>Export</b>          | <b>33909.53</b>               |                |             |
| <hr/>                              |                  |                          |                          |                           |                        |                               |                |             |
| <b>206327PD001A</b>                |                  |                          |                          |                           |                        |                               |                |             |
| LOW: Total Cut                     | 187349.99        | 5.00                     | 30.00                    | 34669.73                  | 0.00                   | 34669.73                      | 0.00           | 0.00        |
| 206327PD001A: Total Cut            | <b>187349.99</b> | <b>5.00</b>              | <b>30.00</b>             | <b>34669.73</b>           | <b>0.00</b>            | <b>34669.73</b>               | <b>0.00</b>    | <b>0.00</b> |
| LOW: Total Fill                    | 18337.27         | 1.12                     | 5.00                     | 760.20                    | 0.00                   | 760.20                        | 0.00           | 0.00        |
| 206327PD001A: Total Fill           | <b>18337.27</b>  | <b>1.12</b>              | <b>5.00</b>              | <b>760.20</b>             | <b>0.00</b>            | <b>760.20</b>                 | <b>0.00</b>    | <b>0.00</b> |
| <b>206327PD001A: Import/Export</b> |                  |                          | <b>Export</b>            | <b>33909.53</b>           | <b>Export</b>          | <b>33909.53</b>               |                |             |

| Area of Interest<br>Cut/Fill Zone  | Area<br>(sq ft)  | Average<br>Depth<br>(ft) | Maximum<br>Depth<br>(ft) | Bank<br>Volume<br>(cu yd) | Shrink<br>Swell<br>(%) | Adjusted<br>Volume<br>(cu yd) | Center of Mass |             |
|------------------------------------|------------------|--------------------------|--------------------------|---------------------------|------------------------|-------------------------------|----------------|-------------|
|                                    |                  |                          |                          |                           |                        |                               | X              | Y           |
| <b>LOW</b>                         |                  |                          |                          |                           |                        |                               |                |             |
| Cut Zone 1                         | 113461.43        | 6.11                     | 29.30                    | 25666.89                  | 0.00                   | 25666.89                      | 5968.11        | 6424.05     |
| Cut Zone 2                         | 38527.23         | 3.10                     | 15.30                    | 4427.44                   | 0.00                   | 4427.44                       | 5377.70        | 6177.22     |
| Cut Zone 3                         | 7971.30          | 0.30                     | 0.64                     | 88.51                     | 0.00                   | 88.51                         | 5471.71        | 6476.64     |
| Misc. Cuts (9)                     | 231.74           | 0.21                     | 0.64                     | 1.81                      | 0.00                   | 1.81                          | 0.00           | 0.00        |
| <b>LOW: Total Cut</b>              | <b>160191.69</b> | <b>5.09</b>              | <b>29.30</b>             | <b>30184.65</b>           | <b>0.00</b>            | <b>30184.65</b>               | <b>0.00</b>    | <b>0.00</b> |
| <br>                               |                  |                          |                          |                           |                        |                               |                |             |
| Fill Zone 1                        | 43541.27         | 0.99                     | 5.70                     | 1588.47                   | 0.00                   | 1588.47                       | 5382.46        | 6420.13     |
| Fill Zone 2                        | 1174.15          | 0.34                     | 0.70                     | 14.69                     | 0.00                   | 14.69                         | 5858.55        | 6306.55     |
| Misc. Fills (15)                   | 577.58           | 0.06                     | 0.31                     | 1.27                      | 0.00                   | 1.27                          | 0.00           | 0.00        |
| <b>LOW: Total Fill</b>             | <b>45293.00</b>  | <b>0.96</b>              | <b>5.70</b>              | <b>1604.43</b>            | <b>0.00</b>            | <b>1604.43</b>                | <b>0.00</b>    | <b>0.00</b> |
| <b>LOW: Import/Export</b>          |                  |                          | <b>Export</b>            | <b>28580.22</b>           | <b>Export</b>          | <b>28580.22</b>               |                |             |
| <hr/>                              |                  |                          |                          |                           |                        |                               |                |             |
| <b>206327PD001A</b>                |                  |                          |                          |                           |                        |                               |                |             |
| LOW: Total Cut                     | 160191.69        | 5.09                     | 29.30                    | 30184.65                  | 0.00                   | 30184.65                      | 0.00           | 0.00        |
| 206327PD001A: Total Cut            | 160191.69        | 5.09                     | 29.30                    | 30184.65                  | 0.00                   | 30184.65                      | 0.00           | 0.00        |
| <br>                               |                  |                          |                          |                           |                        |                               |                |             |
| LOW: Total Fill                    | 45293.00         | 0.96                     | 5.70                     | 1604.43                   | 0.00                   | 1604.43                       | 0.00           | 0.00        |
| 206327PD001A: Total Fill           | 45293.00         | 0.96                     | 5.70                     | 1604.43                   | 0.00                   | 1604.43                       | 0.00           | 0.00        |
| <b>206327PD001A: Import/Export</b> |                  |                          | <b>Export</b>            | <b>28580.22</b>           | <b>Export</b>          | <b>28580.22</b>               |                |             |

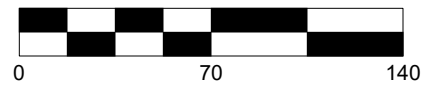
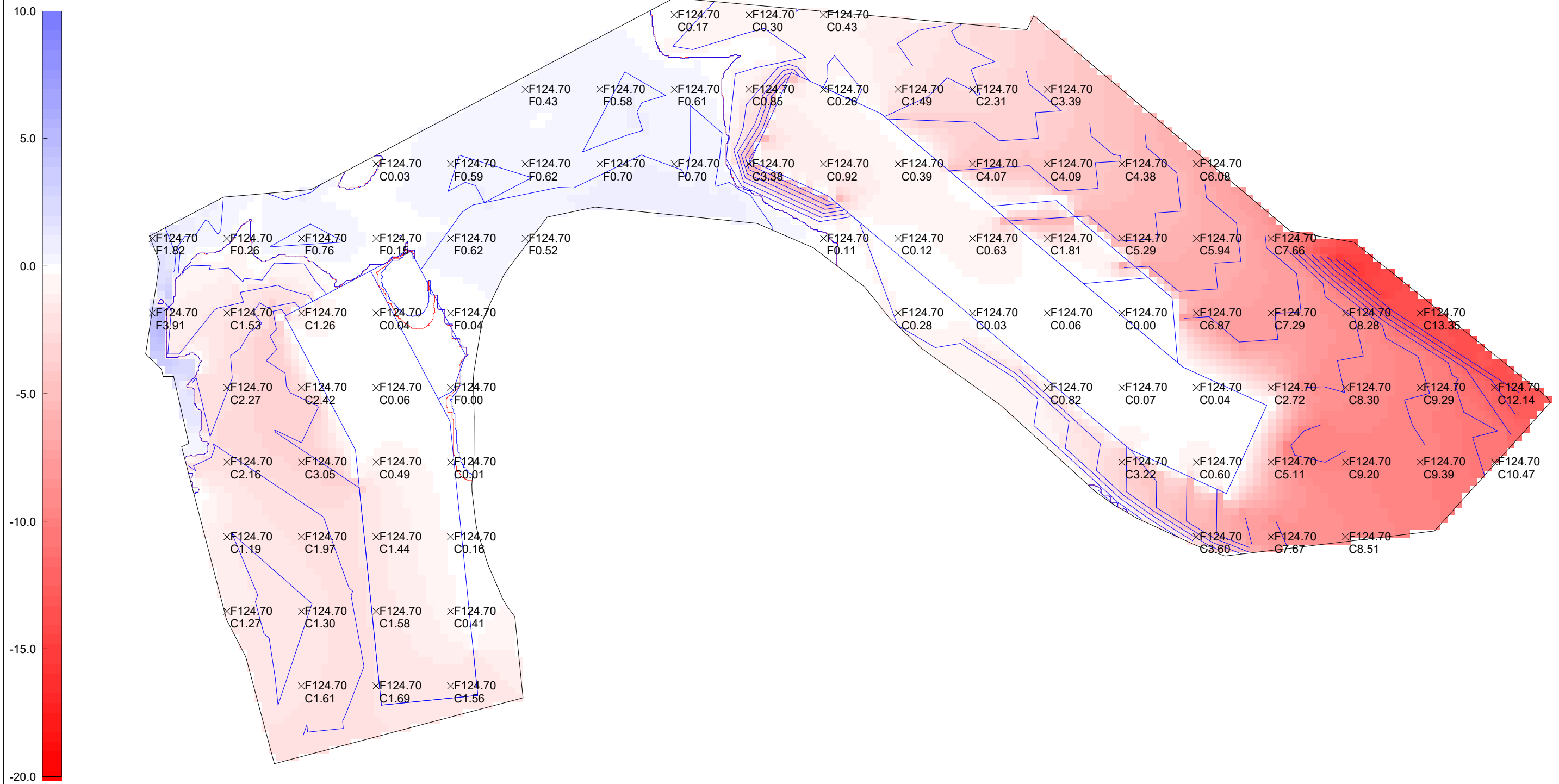

**Cut/Fill Locations Report**  
 206327PD001A: Flood Plain Calculation  
 206327PD001A  
 Proposed vs. Floodplain EL=124.7  
 July 29, 2023 · 10:39 PM

| Area of Interest<br>Cut/Fill Zone  | Area<br>(sq ft)  | Average<br>Depth<br>(ft) | Maximum<br>Depth<br>(ft) | Bank<br>Volume<br>(cu yd) | Shrink<br>Swell<br>(%) | Adjusted<br>Volume<br>(cu yd) | Center of Mass |         |
|------------------------------------|------------------|--------------------------|--------------------------|---------------------------|------------------------|-------------------------------|----------------|---------|
|                                    |                  |                          |                          |                           |                        |                               | X              | Y       |
| <b>LOW</b>                         |                  |                          |                          |                           |                        |                               |                |         |
| Cut Zone 1                         | 205575.00        | 8.02                     | 21.00                    | 61059.64                  | 0.00                   | 61059.64                      | 5747.28        | 6384.44 |
| LOW: Total Cut                     | <b>205575.00</b> | <b>8.02</b>              | <b>21.00</b>             | <b>61059.64</b>           | <b>0.00</b>            | <b>61059.64</b>               | 0.00           | 0.00    |
| <b>LOW: Import/Export</b>          |                  |                          | <b>Export</b>            | <b>61059.64</b>           | <b>Export</b>          | <b>61059.64</b>               |                |         |
| <hr/>                              |                  |                          |                          |                           |                        |                               |                |         |
| <b>206327PD001A</b>                |                  |                          |                          |                           |                        |                               |                |         |
| LOW: Total Cut                     | 205575.00        | 8.02                     | 21.00                    | 61059.64                  | 0.00                   | 61059.64                      | 0.00           | 0.00    |
| 206327PD001A: Total Cut            | <b>205575.00</b> | <b>8.02</b>              | <b>21.00</b>             | <b>61059.64</b>           | <b>0.00</b>            | <b>61059.64</b>               | 0.00           | 0.00    |
| <b>206327PD001A: Import/Export</b> |                  |                          | <b>Export</b>            | <b>61059.64</b>           | <b>Export</b>          | <b>61059.64</b>               |                |         |

| Area of Interest<br>Cut/Fill Zone  | Area<br>(sq ft)  | Average<br>Depth<br>(ft) | Maximum<br>Depth<br>(ft) | Bank<br>Volume<br>(cu yd) | Shrink<br>Swell<br>(%) | Adjusted<br>Volume<br>(cu yd) | Center of Mass |         |
|------------------------------------|------------------|--------------------------|--------------------------|---------------------------|------------------------|-------------------------------|----------------|---------|
|                                    |                  |                          |                          |                           |                        |                               | X              | Y       |
| <b>LOW</b>                         |                  |                          |                          |                           |                        |                               |                |         |
| Cut Zone 1                         | 205509.56        | 7.02                     | 20.00                    | 53446.59                  | 0.00                   | 53446.59                      | 5757.85        | 6383.24 |
| LOW: Total Cut                     | <b>205509.56</b> | <b>7.02</b>              | <b>20.00</b>             | <b>53446.59</b>           | <b>0.00</b>            | <b>53446.59</b>               | 0.00           | 0.00    |
| Misc. Fills (1)                    | 65.44            | 0.34                     | 0.97                     | 0.83                      | 0.00                   | 0.83                          | 0.00           | 0.00    |
| LOW: Total Fill                    | <b>65.44</b>     | <b>0.34</b>              | <b>0.97</b>              | <b>0.83</b>               | <b>0.00</b>            | <b>0.83</b>                   | 0.00           | 0.00    |
| <b>LOW: Import/Export</b>          |                  |                          | <b>Export</b>            | <b>53445.75</b>           | <b>Export</b>          | <b>53445.75</b>               |                |         |
| <b>206327PD001A</b>                |                  |                          |                          |                           |                        |                               |                |         |
| LOW: Total Cut                     | 205509.56        | 7.02                     | 20.00                    | 53446.59                  | 0.00                   | 53446.59                      | 0.00           | 0.00    |
| 206327PD001A: Total Cut            | <b>205509.56</b> | <b>7.02</b>              | <b>20.00</b>             | <b>53446.59</b>           | <b>0.00</b>            | <b>53446.59</b>               | 0.00           | 0.00    |
| LOW: Total Fill                    | 65.44            | 0.34                     | 0.97                     | 0.83                      | 0.00                   | 0.83                          | 0.00           | 0.00    |
| 206327PD001A: Total Fill           | <b>65.44</b>     | <b>0.34</b>              | <b>0.97</b>              | <b>0.83</b>               | <b>0.00</b>            | <b>0.83</b>                   | 0.00           | 0.00    |
| <b>206327PD001A: Import/Export</b> |                  |                          | <b>Export</b>            | <b>53445.75</b>           | <b>Export</b>          | <b>53445.75</b>               |                |         |

| Area of Interest<br>Cut/Fill Zone  | Area<br>(sq ft)  | Average<br>Depth<br>(ft) | Maximum<br>Depth<br>(ft) | Bank<br>Volume<br>(cu yd) | Shrink<br>Swell<br>(%) | Adjusted<br>Volume<br>(cu yd) | Center of Mass |         |
|------------------------------------|------------------|--------------------------|--------------------------|---------------------------|------------------------|-------------------------------|----------------|---------|
|                                    |                  |                          |                          |                           |                        |                               | X              | Y       |
| <b>LOW</b>                         |                  |                          |                          |                           |                        |                               |                |         |
| Cut Zone 1                         | 205291.09        | 6.03                     | 19.00                    | 45838.94                  | 0.00                   | 45838.94                      | 5771.88        | 6381.64 |
| LOW: Total Cut                     | <b>205291.09</b> | <b>6.03</b>              | <b>19.00</b>             | <b>45838.94</b>           | <b>0.00</b>            | <b>45838.94</b>               | 0.00           | 0.00    |
| Misc. Fills (2)                    | 279.51           | 0.69                     | 1.97                     | 7.10                      | 0.00                   | 7.10                          | 0.00           | 0.00    |
| LOW: Total Fill                    | <b>279.51</b>    | <b>0.69</b>              | <b>1.97</b>              | <b>7.10</b>               | <b>0.00</b>            | <b>7.10</b>                   | 0.00           | 0.00    |
| <b>LOW: Import/Export</b>          |                  |                          | <b>Export</b>            | <b>45831.85</b>           | <b>Export</b>          | <b>45831.85</b>               |                |         |
| <b>206327PD001A</b>                |                  |                          |                          |                           |                        |                               |                |         |
| LOW: Total Cut                     | 205291.09        | 6.03                     | 19.00                    | 45838.94                  | 0.00                   | 45838.94                      | 0.00           | 0.00    |
| 206327PD001A: Total Cut            | <b>205291.09</b> | <b>6.03</b>              | <b>19.00</b>             | <b>45838.94</b>           | <b>0.00</b>            | <b>45838.94</b>               | 0.00           | 0.00    |
| LOW: Total Fill                    | 279.51           | 0.69                     | 1.97                     | 7.10                      | 0.00                   | 7.10                          | 0.00           | 0.00    |
| 206327PD001A: Total Fill           | <b>279.51</b>    | <b>0.69</b>              | <b>1.97</b>              | <b>7.10</b>               | <b>0.00</b>            | <b>7.10</b>                   | 0.00           | 0.00    |
| <b>206327PD001A: Import/Export</b> |                  |                          | <b>Export</b>            | <b>45831.85</b>           | <b>Export</b>          | <b>45831.85</b>               |                |         |

| Area of Interest<br>Cut/Fill Zone  | Area<br>(sq ft)  | Average<br>Depth<br>(ft) | Maximum<br>Depth<br>(ft) | Bank<br>Volume<br>(cu yd) | Shrink<br>Swell<br>(%) | Adjusted<br>Volume<br>(cu yd) | Center of Mass |         |
|------------------------------------|------------------|--------------------------|--------------------------|---------------------------|------------------------|-------------------------------|----------------|---------|
|                                    |                  |                          |                          |                           |                        |                               | X              | Y       |
| <b>LOW</b>                         |                  |                          |                          |                           |                        |                               |                |         |
| Cut Zone 1                         | 205104.67        | 5.03                     | 18.00                    | 38238.35                  | 0.00                   | 38238.35                      | 5791.39        | 6379.42 |
| LOW: Total Cut                     | <b>205104.67</b> | <b>5.03</b>              | <b>18.00</b>             | <b>38238.35</b>           | <b>0.00</b>            | <b>38238.35</b>               | 0.00           | 0.00    |
| Misc. Fills (2)                    | 470.33           | 1.17                     | 2.97                     | 20.38                     | 0.00                   | 20.38                         | 0.00           | 0.00    |
| LOW: Total Fill                    | <b>470.33</b>    | <b>1.17</b>              | <b>2.97</b>              | <b>20.38</b>              | <b>0.00</b>            | <b>20.38</b>                  | 0.00           | 0.00    |
| <b>LOW: Import/Export</b>          |                  |                          | <b>Export</b>            | <b>38217.97</b>           | <b>Export</b>          | <b>38217.97</b>               |                |         |
| <b>206327PD001A</b>                |                  |                          |                          |                           |                        |                               |                |         |
| LOW: Total Cut                     | 205104.67        | 5.03                     | 18.00                    | 38238.35                  | 0.00                   | 38238.35                      | 0.00           | 0.00    |
| 206327PD001A: Total Cut            | <b>205104.67</b> | <b>5.03</b>              | <b>18.00</b>             | <b>38238.35</b>           | <b>0.00</b>            | <b>38238.35</b>               | 0.00           | 0.00    |
| LOW: Total Fill                    | 470.33           | 1.17                     | 2.97                     | 20.38                     | 0.00                   | 20.38                         | 0.00           | 0.00    |
| 206327PD001A: Total Fill           | <b>470.33</b>    | <b>1.17</b>              | <b>2.97</b>              | <b>20.38</b>              | <b>0.00</b>            | <b>20.38</b>                  | 0.00           | 0.00    |
| <b>206327PD001A: Import/Export</b> |                  |                          | <b>Export</b>            | <b>38217.97</b>           | <b>Export</b>          | <b>38217.97</b>               |                |         |

| Area of Interest<br>Cut/Fill Zone  | Area<br>(sq ft)  | Average<br>Depth<br>(ft) | Maximum<br>Depth<br>(ft) | Bank<br>Volume<br>(cu yd) | Shrink<br>Swell<br>(%) | Adjusted<br>Volume<br>(cu yd) | Center of Mass |         |
|------------------------------------|------------------|--------------------------|--------------------------|---------------------------|------------------------|-------------------------------|----------------|---------|
|                                    |                  |                          |                          |                           |                        |                               | X              | Y       |
| <b>LOW</b>                         |                  |                          |                          |                           |                        |                               |                |         |
| Cut Zone 1                         | 204431.22        | 4.05                     | 17.00                    | 30649.93                  | 0.00                   | 30649.93                      | 5820.35        | 6376.09 |
| LOW: Total Cut                     | <b>204431.22</b> | <b>4.05</b>              | <b>17.00</b>             | <b>30649.93</b>           | <b>0.00</b>            | <b>30649.93</b>               | 0.00           | 0.00    |
| Misc. Fills (3)                    | 1140.79          | 1.09                     | 3.97                     | 46.11                     | 0.00                   | 46.11                         | 0.00           | 0.00    |
| LOW: Total Fill                    | <b>1140.79</b>   | <b>1.09</b>              | <b>3.97</b>              | <b>46.11</b>              | <b>0.00</b>            | <b>46.11</b>                  | 0.00           | 0.00    |
| <b>LOW: Import/Export</b>          |                  |                          | <b>Export</b>            | <b>30603.82</b>           | <b>Export</b>          | <b>30603.82</b>               |                |         |
| <b>206327PD001A</b>                |                  |                          |                          |                           |                        |                               |                |         |
| LOW: Total Cut                     | 204431.22        | 4.05                     | 17.00                    | 30649.93                  | 0.00                   | 30649.93                      | 0.00           | 0.00    |
| 206327PD001A: Total Cut            | <b>204431.22</b> | <b>4.05</b>              | <b>17.00</b>             | <b>30649.93</b>           | <b>0.00</b>            | <b>30649.93</b>               | 0.00           | 0.00    |
| LOW: Total Fill                    | 1140.79          | 1.09                     | 3.97                     | 46.11                     | 0.00                   | 46.11                         | 0.00           | 0.00    |
| 206327PD001A: Total Fill           | <b>1140.79</b>   | <b>1.09</b>              | <b>3.97</b>              | <b>46.11</b>              | <b>0.00</b>            | <b>46.11</b>                  | 0.00           | 0.00    |
| <b>206327PD001A: Import/Export</b> |                  |                          | <b>Export</b>            | <b>30603.82</b>           | <b>Export</b>          | <b>30603.82</b>               |                |         |

| Area of Interest<br>Cut/Fill Zone  | Area<br>(sq ft)  | Average<br>Depth<br>(ft) | Maximum<br>Depth<br>(ft) | Bank<br>Volume<br>(cu yd) | Shrink<br>Swell<br>(%) | Adjusted<br>Volume<br>(cu yd) | Center of Mass |             |
|------------------------------------|------------------|--------------------------|--------------------------|---------------------------|------------------------|-------------------------------|----------------|-------------|
|                                    |                  |                          |                          |                           |                        |                               | X              | Y           |
| <b>LOW</b>                         |                  |                          |                          |                           |                        |                               |                |             |
| Cut Zone 1                         | 194649.14        | 3.21                     | 16.00                    | 23126.47                  | 0.00                   | 23126.47                      | 5867.11        | 6370.77     |
| Misc. Cuts (8)                     | 187.69           | 0.05                     | 0.08                     | 0.35                      | 0.00                   | 0.35                          | 0.00           | 0.00        |
| <b>LOW: Total Cut</b>              | <b>194836.83</b> | <b>3.20</b>              | <b>16.00</b>             | <b>23126.82</b>           | <b>0.00</b>            | <b>23126.82</b>               | <b>0.00</b>    | <b>0.00</b> |
| Fill Zone 1                        | 7066.61          | 0.11                     | 0.53                     | 28.41                     | 0.00                   | 28.41                         | 5593.53        | 6483.38     |
| Fill Zone 2                        | 1217.65          | 0.69                     | 3.15                     | 31.20                     | 0.00                   | 31.20                         | 5260.06        | 6433.95     |
| Fill Zone 3                        | 1100.14          | 1.85                     | 4.97                     | 75.21                     | 0.00                   | 75.21                         | 5259.17        | 6375.26     |
| Misc. Fills (13)                   | 1481.08          | 0.04                     | 0.32                     | 2.38                      | 0.00                   | 2.38                          | 0.00           | 0.00        |
| <b>LOW: Total Fill</b>             | <b>10865.48</b>  | <b>0.34</b>              | <b>4.97</b>              | <b>137.20</b>             | <b>0.00</b>            | <b>137.20</b>                 | <b>0.00</b>    | <b>0.00</b> |
| <b>LOW: Import/Export</b>          |                  |                          | <b>Export</b>            | <b>22989.62</b>           | <b>Export</b>          | <b>22989.62</b>               |                |             |
| <hr/>                              |                  |                          |                          |                           |                        |                               |                |             |
| <b>206327PD001A</b>                |                  |                          |                          |                           |                        |                               |                |             |
| LOW: Total Cut                     | 194836.83        | 3.20                     | 16.00                    | 23126.82                  | 0.00                   | 23126.82                      | 0.00           | 0.00        |
| 206327PD001A: Total Cut            | <b>194836.83</b> | <b>3.20</b>              | <b>16.00</b>             | <b>23126.82</b>           | <b>0.00</b>            | <b>23126.82</b>               | <b>0.00</b>    | <b>0.00</b> |
| LOW: Total Fill                    | 10865.48         | 0.34                     | 4.97                     | 137.20                    | 0.00                   | 137.20                        | 0.00           | 0.00        |
| 206327PD001A: Total Fill           | <b>10865.48</b>  | <b>0.34</b>              | <b>4.97</b>              | <b>137.20</b>             | <b>0.00</b>            | <b>137.20</b>                 | <b>0.00</b>    | <b>0.00</b> |
| <b>206327PD001A: Import/Export</b> |                  |                          | <b>Export</b>            | <b>22989.62</b>           | <b>Export</b>          | <b>22989.62</b>               |                |             |

| Area of Interest<br>Cut/Fill Zone  | Area<br>(sq ft)  | Average<br>Depth<br>(ft) | Maximum<br>Depth<br>(ft) | Bank<br>Volume<br>(cu yd) | Shrink<br>Swell<br>(%) | Adjusted<br>Volume<br>(cu yd) | Center of Mass |             |
|------------------------------------|------------------|--------------------------|--------------------------|---------------------------|------------------------|-------------------------------|----------------|-------------|
|                                    |                  |                          |                          |                           |                        |                               | X              | Y           |
| <b>LOW</b>                         |                  |                          |                          |                           |                        |                               |                |             |
| Cut Zone 1                         | 109328.98        | 3.91                     | 15.30                    | 15819.15                  | 0.00                   | 15819.15                      | 6001.57        | 6387.14     |
| Cut Zone 2                         | 54133.38         | 1.31                     | 3.30                     | 2632.84                   | 0.00                   | 2632.84                       | 5357.67        | 6256.45     |
| Misc. Cuts (10)                    | 525.40           | 0.06                     | 1.30                     | 1.14                      | 0.00                   | 1.14                          | 0.00           | 0.00        |
| <b>LOW: Total Cut</b>              | <b>163987.75</b> | <b>3.04</b>              | <b>15.30</b>             | <b>18453.13</b>           | <b>0.00</b>            | <b>18453.13</b>               | <b>0.00</b>    | <b>0.00</b> |
|                                    |                  |                          |                          |                           |                        |                               |                |             |
| Fill Zone 1                        | 38357.42         | 0.48                     | 3.85                     | 684.64                    | 0.00                   | 684.64                        | 5491.08        | 6490.12     |
| Fill Zone 2                        | 1575.54          | 0.00                     | 0.00                     | 0.00                      | 0.00                   | 0.00                          | 5911.75        | 6402.89     |
| Fill Zone 3                        | 1401.93          | 2.09                     | 5.67                     | 108.40                    | 0.00                   | 108.40                        | 5261.31        | 6370.31     |
| Misc. Fills (44)                   | 251.75           | 0.18                     | 0.70                     | 1.67                      | 0.00                   | 1.67                          | 0.00           | 0.00        |
| <b>LOW: Total Fill</b>             | <b>41586.63</b>  | <b>0.52</b>              | <b>5.67</b>              | <b>794.72</b>             | <b>0.00</b>            | <b>794.72</b>                 | <b>0.00</b>    | <b>0.00</b> |
| <b>LOW: Import/Export</b>          |                  |                          | <b>Export</b>            | <b>17658.41</b>           | <b>Export</b>          | <b>17658.41</b>               |                |             |
| <hr/>                              |                  |                          |                          |                           |                        |                               |                |             |
| <b>206327PD001A</b>                |                  |                          |                          |                           |                        |                               |                |             |
| LOW: Total Cut                     | 163987.75        | 3.04                     | 15.30                    | 18453.13                  | 0.00                   | 18453.13                      | 0.00           | 0.00        |
| 206327PD001A: Total Cut            | 163987.75        | 3.04                     | 15.30                    | 18453.13                  | 0.00                   | 18453.13                      | 0.00           | 0.00        |
|                                    |                  |                          |                          |                           |                        |                               |                |             |
| LOW: Total Fill                    | 41586.63         | 0.52                     | 5.67                     | 794.72                    | 0.00                   | 794.72                        | 0.00           | 0.00        |
| 206327PD001A: Total Fill           | 41586.63         | 0.52                     | 5.67                     | 794.72                    | 0.00                   | 794.72                        | 0.00           | 0.00        |
| <b>206327PD001A: Import/Export</b> |                  |                          | <b>Export</b>            | <b>17658.41</b>           | <b>Export</b>          | <b>17658.41</b>               |                |             |

## **Attachment 3**

---

### Compensatory Floodplain Storage System Models (HydroCAD Calculations)

**Summary for Pond 1000P: FP-COMP**

[43] Hint: Has no inflow (Outflow=Zero)

| Volume | Invert  | Avail.Storage | Storage Description  |
|--------|---------|---------------|--|
| #1A    | 119.80' | 0 cf          | <b>38.75'W x 105.69'L x 5.00'H Field A</b><br>20,477 cf Overall - 20,477 cf Embedded = 0 cf x 40.0% Voids  |
| #2A    | 119.80' | 16,339 cf     | <b>StormTrap ST2 SingleTrap 4-6 x 18 Inside #1</b><br>Inside= 101.7"W x 54.0"H => 34.42 sf x 15.40'L = 529.9 cf<br>Outside= 101.7"W x 60.0"H => 42.40 sf x 15.40'L = 652.7 cf<br>18 Chambers in 3 Rows<br>25.44' x 92.38' Core + 6.66' Border = 38.75' x 105.69' System  |
| #3B    | 119.80' | 0 cf          | <b>30.27'W x 121.08'L x 4.50'H Field B</b><br>16,494 cf Overall - 16,494 cf Embedded = 0 cf x 40.0% Voids  |
| #4B    | 119.80' | 12,939 cf     | <b>StormTrap ST2 SingleTrap 4-0 x 14 Inside #3</b><br>Inside= 101.7"W x 48.0"H => 30.55 sf x 15.40'L = 470.3 cf<br>Outside= 101.7"W x 54.0"H => 38.16 sf x 15.40'L = 587.4 cf<br>14 Chambers in 2 Rows<br>16.96' x 107.77' Core + 6.66' Border = 30.27' x 121.08' System |
|        |         | 29,278 cf     | Total Available Storage  |

Storage Group A created with Chamber Wizard

Storage Group B created with Chamber Wizard

**Pond 1000P: FP-COMP - Chamber Wizard Field A**

**Chamber Model = StormTrap ST2 SingleTrap 4-6 (StormTrap ST2 SingleTrap® Type II+IV)**

Inside= 101.7"W x 54.0"H => 34.42 sf x 15.40'L = 529.9 cf

Outside= 101.7"W x 60.0"H => 42.40 sf x 15.40'L = 652.7 cf

6 Chambers/Row x 15.40' Long = 92.38' Row Length +79.9" Border x 2 = 105.69' Base Length

3 Rows x 101.7" Wide + 79.9" Side Border x 2 = 38.75' Base Width

60.0" Chamber Height = 5.00' Field Height

18 Chambers x 529.9 cf + 6,800.0 cf Border = 16,338.9 cf Chamber Storage

18 Chambers x 652.7 cf + 8,728.0 cf Border = 20,477.0 cf Displacement

Chamber Storage = 16,338.9 cf = 0.375 af

Overall Storage Efficiency = 79.8%

Overall System Size = 105.69' x 38.75' x 5.00'

18 Chambers (plus border)

758.4 cy Field

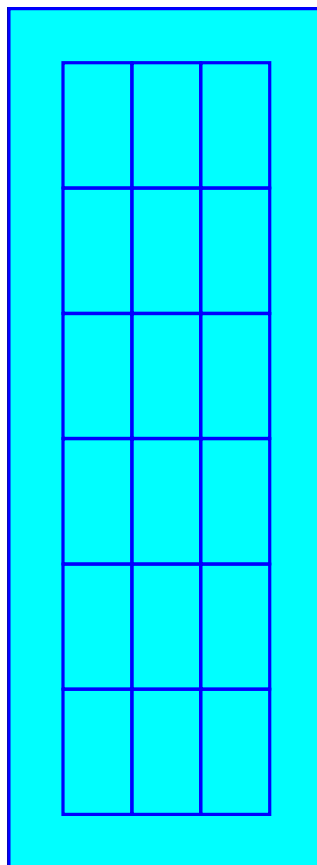

**Pond 1000P: FP-COMP - Chamber Wizard Field B**

**Chamber Model = StormTrap ST2 SingleTrap 4-0 (StormTrap ST2 SingleTrap® Type II+IV)**

Inside= 101.7"W x 48.0"H => 30.55 sf x 15.40'L = 470.3 cf

Outside= 101.7"W x 54.0"H => 38.16 sf x 15.40'L = 587.4 cf

7 Chambers/Row x 15.40' Long = 107.77' Row Length +79.9" Border x 2 = 121.08' Base Length

2 Rows x 101.7" Wide + 79.9" Side Border x 2 = 30.27' Base Width

54.0" Chamber Height = 4.50' Field Height

14 Chambers x 470.3 cf + 6,355.3 cf Border = 12,939.1 cf Chamber Storage

14 Chambers x 587.4 cf + 8,269.6 cf Border = 16,493.8 cf Displacement

Chamber Storage = 12,939.1 cf = 0.297 af

Overall Storage Efficiency = 78.4%

Overall System Size = 121.08' x 30.27' x 4.50'

14 Chambers (plus border)

610.9 cy Field

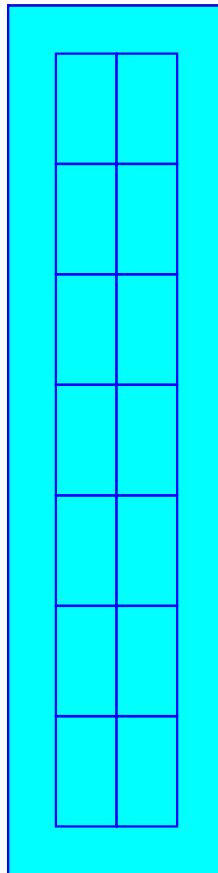

206327HC003A

NRCC 24-hr D 100-Year Rainfall=8.36"

Prepared by Beals & Thomas Inc

Printed 8/22/2023

HydroCAD® 10.20-3c s/n 04493 © 2023 HydroCAD Software Solutions LLC

Stage-Area-Storage for Pond 1000P: FP-COMP

| Elevation<br>(feet) | Storage<br>(cubic-feet) | Elevation<br>(feet) | Storage<br>(cubic-feet) |
|---------------------|-------------------------|---------------------|-------------------------|
| 119.80              | 0                       | 122.40              | 17,851                  |
| 119.85              | 343                     | 122.45              | 18,194                  |
| 119.90              | 687                     | 122.50              | 18,537                  |
| 119.95              | 1,030                   | 122.55              | 18,881                  |
| 120.00              | 1,373                   | 122.60              | 19,224                  |
| 120.05              | 1,716                   | 122.65              | 19,567                  |
| 120.10              | 2,060                   | 122.70              | 19,910                  |
| 120.15              | 2,403                   | 122.75              | 20,254                  |
| 120.20              | 2,746                   | 122.80              | 20,597                  |
| 120.25              | 3,090                   | 122.85              | 20,940                  |
| 120.30              | 3,433                   | 122.90              | 21,283                  |
| 120.35              | 3,776                   | 122.95              | 21,627                  |
| 120.40              | 4,119                   | 123.00              | 21,970                  |
| 120.45              | 4,463                   | 123.05              | 22,313                  |
| 120.50              | 4,806                   | 123.10              | 22,657                  |
| 120.55              | 5,149                   | 123.15              | 23,000                  |
| 120.60              | 5,493                   | 123.20              | 23,343                  |
| 120.65              | 5,836                   | 123.25              | 23,686                  |
| 120.70              | 6,179                   | 123.30              | 24,030                  |
| 120.75              | 6,522                   | 123.35              | 24,373                  |
| 120.80              | 6,866                   | 123.40              | 24,716                  |
| 120.85              | 7,209                   | 123.45              | 25,060                  |
| 120.90              | 7,552                   | 123.50              | 25,403                  |
| 120.95              | 7,895                   | 123.55              | 25,746                  |
| 121.00              | 8,239                   | 123.60              | 26,089                  |
| 121.05              | 8,582                   | 123.65              | 26,433                  |
| 121.10              | 8,925                   | 123.70              | 26,776                  |
| 121.15              | 9,269                   | 123.75              | 27,119                  |
| 121.20              | 9,612                   | 123.80              | 27,463                  |
| 121.25              | 9,955                   | 123.85              | 27,644                  |
| 121.30              | 10,298                  | 123.90              | 27,826                  |
| 121.35              | 10,642                  | 123.95              | 28,007                  |
| 121.40              | 10,985                  | 124.00              | 28,189                  |
| 121.45              | 11,328                  | 124.05              | 28,370                  |
| 121.50              | 11,672                  | 124.10              | 28,552                  |
| 121.55              | 12,015                  | 124.15              | 28,733                  |
| 121.60              | 12,358                  | 124.20              | 28,915                  |
| 121.65              | 12,701                  | 124.25              | 29,096                  |
| 121.70              | 13,045                  | 124.30              | 29,278                  |
| 121.75              | 13,388                  | 124.35              | 29,278                  |
| 121.80              | 13,731                  | 124.40              | 29,278                  |
| 121.85              | 14,075                  | 124.45              | 29,278                  |
| 121.90              | 14,418                  | 124.50              | 29,278                  |
| 121.95              | 14,761                  | 124.55              | 29,278                  |
| 122.00              | 15,104                  | 124.60              | 29,278                  |
| 122.05              | 15,448                  | 124.65              | 29,278                  |
| 122.10              | 15,791                  | 124.70              | 29,278                  |
| 122.15              | 16,134                  | 124.75              | 29,278                  |
| 122.20              | 16,478                  | 124.80              | 29,278                  |
| 122.25              | 16,821                  |                     |                         |
| 122.30              | 17,164                  |                     |                         |
| 122.35              | 17,507                  |                     |                         |

## **Attachment 4**

---

### Subsurface Stormwater Storage System Models (HydroCAD Calculations)

**206327HC002A**

*NRCC 24-hr D 100-Year Rainfall=8.36"*

Prepared by Beals & Thomas Inc

Printed 8/22/2023

HydroCAD® 10.20-3c s/n 04493 © 2023 HydroCAD Software Solutions LLC

---

### **Summary for Reach 60R: DP-6**

[40] Hint: Not Described (Outflow=Inflow)

Inflow Area = 7.951 ac, 48.74% Impervious, Inflow Depth > 1.33" for 100-Year event  
Inflow = 5.67 cfs @ 12.13 hrs, **Volume= 0.879 af**  
Outflow = 5.67 cfs @ 12.13 hrs, Volume= 0.879 af, Atten= 0%, Lag= 0.0 min

Routing by Stor-Ind+Trans method, Time Span= 0.00-36.00 hrs, dt= 0.05 hrs

**206327HC003A**

*NRCC 24-hr D 100-Year Rainfall=8.36"*

Prepared by Beals & Thomas Inc

Printed 8/22/2023

HydroCAD® 10.20-3c s/n 04493 © 2023 HydroCAD Software Solutions LLC

---

### **Summary for Reach 600R: DP-6**

[40] Hint: Not Described (Outflow=Inflow)

Inflow Area = 7.951 ac, 62.92% Impervious, Inflow Depth > 1.85" for 100-Year event  
Inflow = 3.95 cfs @ 12.18 hrs, **Volume= 1.226 af**  
Outflow = 3.95 cfs @ 12.18 hrs, Volume= 1.226 af, Atten= 0%, Lag= 0.0 min

Routing by Stor-Ind+Trans method, Time Span= 0.00-36.00 hrs, dt= 0.05 hrs

**Summary for Pond 200P: P-SUBSURFACE-2**

Inflow Area = 1.027 ac, 72.64% Impervious, Inflow Depth = 6.10" for 100-Year event  
 Inflow = 4.94 cfs @ 12.15 hrs, Volume= 0.522 af  
 Outflow = 1.60 cfs @ 12.47 hrs, Volume= 0.521 af, Atten= 68%, Lag= 19.2 min  
 Primary = 1.60 cfs @ 12.47 hrs, Volume= 0.521 af  
 Routed to Reach 200R : DP-2

Routing by Stor-Ind method, Time Span= 0.00-36.00 hrs, dt= 0.05 hrs  
 Starting Elev= 120.30' Surf.Area= 0.053 ac Storage= 0.023 af  
 Peak Elev= 123.78' @ 12.47 hrs Surf.Area= 0.053 ac Storage= 0.186 af (0.163 af above start)

Plug-Flow detention time= 176.3 min calculated for 0.497 af (95% of inflow)  
 Center-of-Mass det. time= 121.2 min ( 913.7 - 792.5 )

| Volume | Invert  | Avail.Storage | Storage Description  |
|--------|---------|---------------|--|
| #1A    | 119.80' | 0.000 af      | <b>38.75"W x 59.50"L x 4.50"H Field A</b><br>0.238 af Overall - 0.238 af Embedded = 0.000 af x 40.0% Voids   |
| #2A    | 119.80' | 0.187 af      | <b>StormTrap ST2 SingleTrap 4-0 x 9 Inside #1</b><br>Inside= 101.7"W x 48.0"H => 30.55 sf x 15.40'L = 470.3 cf<br>Outside= 101.7"W x 54.0"H => 38.16 sf x 15.40'L = 587.4 cf<br>9 Chambers in 3 Rows<br>25.44' x 46.19' Core + 6.66' Border = 38.75' x 59.50' System |
|        |         | 0.187 af      | Total Available Storage  |

Storage Group A created with Chamber Wizard

| Device | Routing  | Invert  | Outlet Devices   |
|--------|----------|---------|--|
| #1     | Primary  | 120.30' | <b>12.0" Round Culvert</b><br>L= 15.0' CPP, square edge headwall, Ke= 0.500<br>Inlet / Outlet Invert= 120.30' / 120.00' S= 0.0200 '/' Cc= 0.900<br>n= 0.013 Corrugated PE, smooth interior, Flow Area= 0.79 sf |
| #2     | Device 1 | 120.30' | <b>3.0" Vert. Orifice/Grate</b> C= 0.600 Limited to weir flow at low heads   |
| #3     | Device 1 | 122.00' | <b>6.0" Vert. Orifice/Grate</b> C= 0.600 Limited to weir flow at low heads   |
| #4     | Primary  | 124.00' | <b>4.0' long x 2.00' rise Sharp-Crested Rectangular Weir</b><br>0 End Contraction(s) 4.2' Crest Height   |

**Primary OutFlow** Max=1.60 cfs @ 12.47 hrs HW=123.78' (Free Discharge)

- 1=Culvert (Passes 1.60 cfs of 6.53 cfs potential flow)
- 2=Orifice/Grate (Orifice Controls 0.43 cfs @ 8.82 fps)
- 3=Orifice/Grate (Orifice Controls 1.17 cfs @ 5.96 fps)
- 4=Sharp-Crested Rectangular Weir ( Controls 0.00 cfs)

**Pond 200P: P-SUBSURFACE-2 - Chamber Wizard Field A**

**Chamber Model = StormTrap ST2 SingleTrap 4-0 (StormTrap ST2 SingleTrap® Type II+IV)**

Inside= 101.7"W x 48.0"H => 30.55 sf x 15.40'L = 470.3 cf

Outside= 101.7"W x 54.0"H => 38.16 sf x 15.40'L = 587.4 cf

3 Chambers/Row x 15.40' Long = 46.19' Row Length +79.9" Border x 2 = 59.50' Base Length

3 Rows x 101.7" Wide + 79.9" Side Border x 2 = 38.75' Base Width

54.0" Chamber Height = 4.50' Field Height

9 Chambers x 470.3 cf + 3,910.4 cf Border = 8,142.8 cf Chamber Storage

9 Chambers x 587.4 cf + 5,088.3 cf Border = 10,375.3 cf Displacement

Chamber Storage = 8,142.8 cf = 0.187 af

Overall Storage Efficiency = 78.5%

Overall System Size = 59.50' x 38.75' x 4.50'

9 Chambers (plus border)

384.3 cy Field

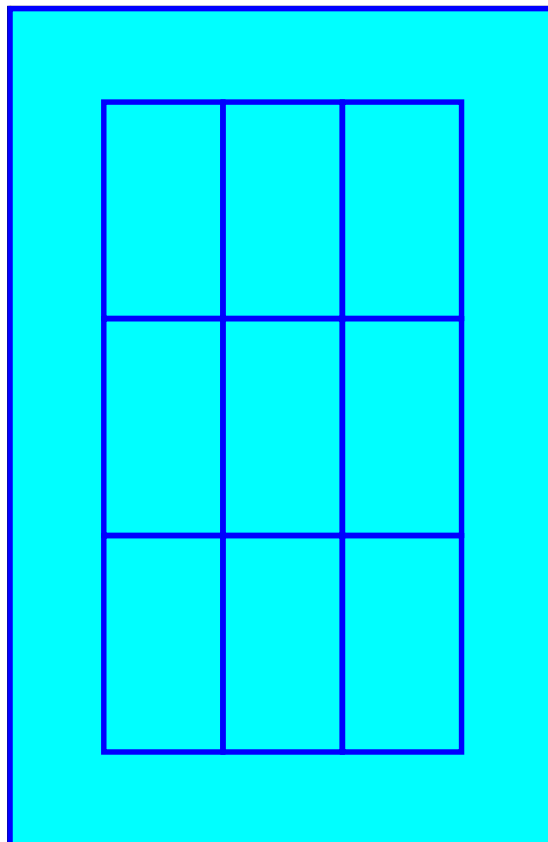

**Stage-Area-Storage for Pond 200P: P-SUBSURFACE-2**

| Elevation<br>(feet) | Storage<br>(acre-feet) | Elevation<br>(feet) | Storage<br>(acre-feet) | Elevation<br>(feet) | Storage<br>(acre-feet) |
|---------------------|------------------------|---------------------|------------------------|---------------------|------------------------|
| 119.80              | 0.000                  | 122.40              | 0.122                  | 125.00              | 0.187                  |
| 119.85              | 0.002                  | 122.45              | 0.124                  | 125.05              | 0.187                  |
| 119.90              | 0.005                  | 122.50              | 0.126                  | 125.10              | 0.187                  |
| 119.95              | 0.007                  | 122.55              | 0.129                  | 125.15              | 0.187                  |
| 120.00              | 0.009                  | 122.60              | 0.131                  | 125.20              | 0.187                  |
| 120.05              | 0.012                  | 122.65              | 0.133                  | 125.25              | 0.187                  |
| 120.10              | 0.014                  | 122.70              | 0.136                  | 125.30              | 0.187                  |
| 120.15              | 0.016                  | 122.75              | 0.138                  | 125.35              | 0.187                  |
| 120.20              | 0.019                  | 122.80              | 0.140                  | 125.40              | 0.187                  |
| 120.25              | 0.021                  | 122.85              | 0.143                  | 125.45              | 0.187                  |
| <b>120.30</b>       | <b>0.023</b>           | 122.90              | 0.145                  | 125.50              | 0.187                  |
| 120.35              | 0.026                  | 122.95              | 0.147                  | 125.55              | 0.187                  |
| 120.40              | 0.028                  | 123.00              | 0.150                  | 125.60              | 0.187                  |
| 120.45              | 0.030                  | 123.05              | 0.152                  | 125.65              | 0.187                  |
| 120.50              | 0.033                  | 123.10              | 0.154                  | 125.70              | 0.187                  |
| 120.55              | 0.035                  | 123.15              | 0.157                  | 125.75              | 0.187                  |
| 120.60              | 0.037                  | 123.20              | 0.159                  | 125.80              | 0.187                  |
| 120.65              | 0.040                  | 123.25              | 0.161                  | 125.85              | 0.187                  |
| 120.70              | 0.042                  | 123.30              | 0.164                  | 125.90              | 0.187                  |
| 120.75              | 0.044                  | 123.35              | 0.166                  | 125.95              | 0.187                  |
| 120.80              | 0.047                  | 123.40              | 0.168                  | 126.00              | 0.187                  |
| 120.85              | 0.049                  | 123.45              | 0.171                  |                     |                        |
| 120.90              | 0.051                  | 123.50              | 0.173                  |                     |                        |
| 120.95              | 0.054                  | 123.55              | 0.175                  |                     |                        |
| 121.00              | 0.056                  | 123.60              | 0.178                  |                     |                        |
| 121.05              | 0.058                  | 123.65              | 0.180                  |                     |                        |
| 121.10              | 0.061                  | 123.70              | 0.182                  |                     |                        |
| 121.15              | 0.063                  | 123.75              | 0.185                  |                     |                        |
| 121.20              | 0.065                  | 123.80              | 0.187                  |                     |                        |
| 121.25              | 0.068                  | 123.85              | 0.187                  |                     |                        |
| 121.30              | 0.070                  | 123.90              | 0.187                  |                     |                        |
| 121.35              | 0.072                  | 123.95              | 0.187                  |                     |                        |
| 121.40              | 0.075                  | 124.00              | 0.187                  |                     |                        |
| 121.45              | 0.077                  | 124.05              | 0.187                  |                     |                        |
| 121.50              | 0.079                  | 124.10              | 0.187                  |                     |                        |
| 121.55              | 0.082                  | 124.15              | 0.187                  |                     |                        |
| 121.60              | 0.084                  | 124.20              | 0.187                  |                     |                        |
| 121.65              | 0.086                  | 124.25              | <b>0.187</b>           |                     |                        |
| 121.70              | 0.089                  | 124.30              | <b>0.187</b>           |                     |                        |
| 121.75              | 0.091                  | 124.35              | 0.187                  |                     |                        |
| 121.80              | 0.093                  | 124.40              | 0.187                  |                     |                        |
| 121.85              | 0.096                  | 124.45              | 0.187                  |                     |                        |
| 121.90              | 0.098                  | 124.50              | 0.187                  |                     |                        |
| 121.95              | 0.100                  | 124.55              | 0.187                  |                     |                        |
| 122.00              | 0.103                  | 124.60              | 0.187                  |                     |                        |
| 122.05              | 0.105                  | 124.65              | 0.187                  |                     |                        |
| 122.10              | 0.107                  | <b>124.70</b>       | <b>0.187</b>           |                     |                        |
| 122.15              | 0.110                  | 124.75              | 0.187                  |                     |                        |
| 122.20              | 0.112                  | 124.80              | 0.187                  |                     |                        |
| 122.25              | 0.114                  | 124.85              | 0.187                  |                     |                        |
| 122.30              | 0.117                  | 124.90              | 0.187                  |                     |                        |
| 122.35              | 0.119                  | 124.95              | 0.187                  |                     |                        |

### Summary for Pond 300P: P-SUBSURFACE-3

Inflow Area = 0.370 ac, 83.79% Impervious, Inflow Depth = 6.92" for 100-Year event  
 Inflow = 2.55 cfs @ 12.13 hrs, Volume= 0.213 af  
 Outflow = 1.92 cfs @ 12.19 hrs, Volume= 0.213 af, Atten= 24%, Lag= 3.7 min  
 Primary = 1.92 cfs @ 12.19 hrs, Volume= 0.213 af  
 Routed to Reach 300R : DP-3

Routing by Stor-Ind method, Time Span= 0.00-36.00 hrs, dt= 0.05 hrs  
 Starting Elev= 120.25' Surf.Area= 0.012 ac Storage= 0.001 af  
 Peak Elev= 123.29' @ 12.19 hrs Surf.Area= 0.012 ac Storage= 0.023 af (0.022 af above start)

Plug-Flow detention time= 17.5 min calculated for 0.212 af (99% of inflow)  
 Center-of-Mass det. time= 10.1 min ( 800.6 - 790.5 )

| Volume | Invert  | Avail.Storage | Storage Description  |
|--------|---------|---------------|--|
| #1A    | 120.00' | 0.011 af      | <b>20.50'W x 24.98'L x 3.50'H Field A</b><br>0.041 af Overall - 0.013 af Embedded = 0.028 af x 40.0% Voids   |
| #2A    | 120.50' | 0.013 af      | <b>ADS_StormTech SC-740 +Cap</b> x 12 Inside #1<br>Effective Size= 44.6"W x 30.0"H => 6.45 sf x 7.12'L = 45.9 cf<br>Overall Size= 51.0"W x 30.0"H x 7.56'L with 0.44' Overlap<br>12 Chambers in 4 Rows |
|        |         | 0.024 af      | Total Available Storage  |

Storage Group A created with Chamber Wizard

| Device | Routing  | Invert  | Outlet Devices   |
|--------|----------|---------|--|
| #1     | Primary  | 120.00' | <b>12.0" Round Culvert</b><br>L= 25.0' CPP, square edge headwall, Ke= 0.500<br>Inlet / Outlet Invert= 120.00' / 119.50' S= 0.0200 '/' Cc= 0.900<br>n= 0.013 Corrugated PE, smooth interior, Flow Area= 0.79 sf |
| #2     | Device 1 | 120.25' | <b>4.0" Vert. Orifice/Grate</b> C= 0.600 Limited to weir flow at low heads   |
| #3     | Device 1 | 121.40' | <b>6.0" Vert. Orifice/Grate</b> C= 0.600 Limited to weir flow at low heads   |
| #4     | Device 1 | 123.30' | <b>4.0' long x 1.70' rise Sharp-Crested Rectangular Weir</b><br>2 End Contraction(s) 3.3' Crest Height   |

**Primary OutFlow** Max=1.90 cfs @ 12.19 hrs HW=123.24' (Free Discharge)

- 1=Culvert (Passes 1.90 cfs of 6.27 cfs potential flow)
- 2=Orifice/Grate (Orifice Controls 0.71 cfs @ 8.10 fps)
- 3=Orifice/Grate (Orifice Controls 1.19 cfs @ 6.08 fps)
- 4=Sharp-Crested Rectangular Weir ( Controls 0.00 cfs)

**Pond 300P: P-SUBSURFACE-3 - Chamber Wizard Field A**

**Chamber Model = ADS\_StormTech SC-740 +Cap (ADS StormTech® SC-740 with cap length)**

Effective Size= 44.6"W x 30.0"H => 6.45 sf x 7.12'L = 45.9 cf

Overall Size= 51.0"W x 30.0"H x 7.56'L with 0.44' Overlap

51.0" Wide + 6.0" Spacing = 57.0" C-C Row Spacing

3 Chambers/Row x 7.12' Long +0.81' Cap Length x 2 = 22.98' Row Length +12.0" End Stone x 2 = 24.98' Base Length

4 Rows x 51.0" Wide + 6.0" Spacing x 3 + 12.0" Side Stone x 2 = 20.50' Base Width

6.0" Stone Base + 30.0" Chamber Height + 6.0" Stone Cover = 3.50' Field Height

12 Chambers x 45.9 cf = 551.3 cf Chamber Storage

1,792.1 cf Field - 551.3 cf Chambers = 1,240.8 cf Stone x 40.0% Voids = 496.3 cf Stone Storage

Chamber Storage + Stone Storage = 1,047.6 cf = 0.024 af

Overall Storage Efficiency = 58.5%

Overall System Size = 24.98' x 20.50' x 3.50'

12 Chambers

66.4 cy Field

46.0 cy Stone

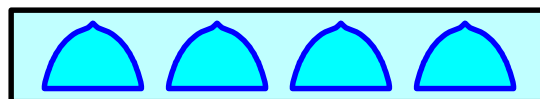
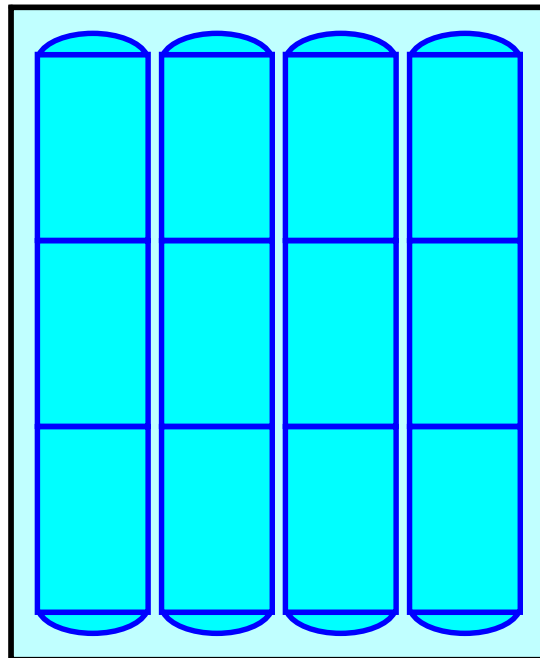

**Stage-Area-Storage for Pond 300P: P-SUBSURFACE-3**

| Elevation<br>(feet) | Storage<br>(acre-feet) | Elevation<br>(feet) | Storage<br>(acre-feet) |
|---------------------|------------------------|---------------------|------------------------|
| 120.00              | 0.000                  | 122.60              | 0.020                  |
| 120.05              | 0.000                  | 122.65              | 0.020                  |
| 120.10              | 0.000                  | 122.70              | 0.020                  |
| 120.15              | 0.001                  | 122.75              | 0.020                  |
| 120.20              | 0.001                  | 122.80              | 0.021                  |
| <b>120.25</b>       | <b>0.001</b>           | 122.85              | 0.021                  |
| 120.30              | 0.001                  | 122.90              | 0.021                  |
| 120.35              | 0.002                  | 122.95              | 0.021                  |
| 120.40              | 0.002                  | 123.00              | 0.022                  |
| 120.45              | 0.002                  | 123.05              | 0.022                  |
| 120.50              | 0.002                  | 123.10              | 0.022                  |
| 120.55              | 0.003                  | 123.15              | 0.022                  |
| 120.60              | 0.003                  | 123.20              | 0.023                  |
| 120.65              | 0.004                  | 123.25              | 0.023                  |
| 120.70              | 0.004                  | 123.30              | 0.023                  |
| 120.75              | 0.005                  | 123.35              | 0.023                  |
| 120.80              | 0.005                  | 123.40              | 0.024                  |
| 120.85              | 0.006                  | 123.45              | 0.024                  |
| 120.90              | 0.006                  | 123.50              | <b>0.024</b>           |
| 120.95              | 0.006                  | 123.55              | 0.024                  |
| 121.00              | 0.007                  | 123.60              | 0.024                  |
| 121.05              | 0.007                  | 123.65              | 0.024                  |
| 121.10              | 0.008                  | 123.70              | 0.024                  |
| 121.15              | 0.008                  | 123.75              | 0.024                  |
| 121.20              | 0.009                  | 123.80              | 0.024                  |
| 121.25              | 0.009                  | 123.85              | 0.024                  |
| 121.30              | 0.009                  | 123.90              | 0.024                  |
| 121.35              | 0.010                  | 123.95              | 0.024                  |
| 121.40              | 0.010                  | 124.00              | 0.024                  |
| 121.45              | 0.011                  | 124.05              | 0.024                  |
| 121.50              | 0.011                  | 124.10              | 0.024                  |
| 121.55              | 0.012                  | 124.15              | 0.024                  |
| 121.60              | 0.012                  | 124.20              | 0.024                  |
| 121.65              | 0.012                  | 124.25              | 0.024                  |
| 121.70              | 0.013                  | 124.30              | 0.024                  |
| 121.75              | 0.013                  | 124.35              | 0.024                  |
| 121.80              | 0.014                  | 124.40              | 0.024                  |
| 121.85              | 0.014                  | 124.45              | 0.024                  |
| 121.90              | 0.014                  | 124.50              | 0.024                  |
| 121.95              | 0.015                  | 124.55              | 0.024                  |
| 122.00              | 0.015                  | 124.60              | 0.024                  |
| 122.05              | 0.016                  | 124.65              | 0.024                  |
| 122.10              | 0.016                  | <b>124.70</b>       | <b>0.024</b>           |
| 122.15              | 0.016                  | 124.75              | 0.024                  |
| 122.20              | 0.017                  | 124.80              | 0.024                  |
| 122.25              | 0.017                  | 124.85              | 0.024                  |
| 122.30              | 0.017                  | 124.90              | 0.024                  |
| 122.35              | 0.018                  | 124.95              | 0.024                  |
| 122.40              | 0.018                  | 125.00              | 0.024                  |
| 122.45              | 0.019                  |                     |                        |
| 122.50              | 0.019                  |                     |                        |
| 122.55              | 0.019                  |                     |                        |

**Attachment 5**  
**Recharge/Drawdown, Water Quality, TSS & Sizing Calculations**

---



## Standard 3: Groundwater Recharge

### Groundwater Recharge Volume Required:

$R_v = F \times \text{Impervious Area}$ , where:

$R_v$  = Required Recharge Volume [Ac-ft]

$F$  = Target Depth Factor associated with each Hydrologic Soil Group (HSG) [in]

**Impervious Area** = Total Pavement and Rooftop Area under Post-development Conditions [Ac]

|  |      |    | Impervious Area<br>[Acres] | Required Recharge<br>Volume [Ac-ft] |              |
|--|------|----|----------------------------|-------------------------------------|--------------|
| HSG "A", use F =   | 0.6  | in | 1.127                      | 0.056                               | Net Increase |
| HSG "B", use F =   | 0.35 | in | 0.000                      | 0.000                               |              |
| HSG "C", use F =   | 0.25 | in | 0.000                      | 0.000                               |              |
| HSG "D", use F =   | 0.1  | in | 0.000                      | 0.000                               |              |
| <b>Total Required Recharge Volume (<math>R_v</math>) =</b> |      |    |                            | <b>0.056</b>                        | <b>Ac-ft</b> |

### Capture Area Adjustment: (Ref: DEP Handbook V.3 Ch.1 P.27-28)

Total Site Impervious Area (Total) = 3.278 Acres

Impervious Area Draining to Infiltrative BMPs (infil) = 2.44 Acres

Percent Imp. Area Draining to Infiltrative BMPs = 74.4%

Capture Area Adjustment Factor = (Total)/(Infil) =  $C_a$  = 1.34

**Adjusted Required Recharge Volume =  $C_a \times R_v$**  **0.076 Ac-ft**

### Groundwater Recharge Volume Provided :

| BMP                                     | Provided Recharge<br>Volume [Ac-ft] |                     |
|---|-------------------------------------|---------------------|
| Subsurface #1                           | 0.096                               | Below Lowest Outlet |
| Subsurface #2                           | 0.023                               | Below Lowest Outlet |
| Subsurface #3                           | 0.001                               | Below Lowest Outlet |
| <b>Total Provided Recharge Volume =</b> | <b>0.120</b>                        | <b>Ac-ft</b>        |

**PROVIDED GROUNDWATER RECHARGE VOLUME IS GREATER THAN OR EQUAL TO THE REQUIRED RECHARGE VOLUME,  
THEREFORE PROPOSED STORMWATER MANAGEMENT DESIGN IS IN COMPLIANCE WITH STANDARD 3.**

JOB NO. 2063.27  
JOB: NOVO Riverside Commons

COMPUTED BY: TJM  
DATE: 09/18/23

CHECKED BY: \_\_\_\_\_  
DATE: \_\_\_\_\_



### Standard 3: Drawdown

$$\text{Drawdown Time} = \frac{Rv}{(K) (\text{Bottom Area})}$$

where: Rv = Storage Volume Below Outlet [Ac-ft]  
 K= Infiltration Rate [in/hr]  
 Bottom Area= Bottom Area of Recharge System [Ac]

#### Subsurface #1

Rv = 0.096 Ac-ft  
 K = 0.270 in/hr      Conservative Rawls for HSG C  
 Bottom Area = 0.127 Acres  
**Drawdown Time = 33.596 Hours**      < 72 Hours, Design is in compliance with the standard.

---

#### Subsurface #2

Rv = 0.023 Ac-ft  
 K = 0.270 in/hr      Conservative Rawls for HSG C  
 Bottom Area = 0.053 Acres  
**Drawdown Time = 19.287 Hours**      < 72 Hours, Design is in compliance with the standard.

---

#### Subsurface #3

Rv = 0.001 Ac-ft  
 K = 0.270 in/hr      Conservative Rawls for HSG C  
 Bottom Area = 0.012 Acres  
**Drawdown Time = 3.704 Hours**      < 72 Hours, Design is in compliance with the standard.

---

Note:

- The infiltration BMPs have been designed to fully drain within 72 hours, therefore the proposed stormwater management design is in compliance with Standard 3 .
- Infiltration Rate based on Volume 3, Chapter 1, Table 2.3.3 *Rawls Rates* from the 2008 MA DEP Stormwater Management Handbook.

JOB NO. 2063.27

COMPUTED BY: TJM

CHECKED BY: \_\_\_\_\_

JOB: NOVO Riverside Commons

DATE: 09/18/23

DATE: \_\_\_\_\_



## Standard 4: Water Quality Volume Summary

$$V_{WQ} = (D_{WQ} / 12 \text{ in/ft}) \times (A_{IMP} \times 43,560 \text{ SF/Ac}) \text{ where:}$$

$V_{WQ}$  = Required Water Quality Volume [CF]

$D_{WQ}$  = Water Quality Depth : 1-inch for discharges within a Zone II or Interim Wellhead Protection Area, to or near critical areas, runoff from LUHPPL, or exfiltration to soil with infiltration rate 2.4 in/hr or greater; ½-inch for discharges to other areas.

$A_{IMP}$  = Post-development Impervious Area; may exclude roof top areas [Ac]

### Required Water Quality Volume:

| Drainage Area/<br>Treatment Train           | $A_{IMP}$ [Ac] | $D_{WQ}$ [in] | $V_{WQ}$ Required [CF] |  |
|---|----------------|---------------|------------------------|--|
| PDA-1A*                                     | 0.761          | 1             | 2,762                  | *Includes Path and Fire Access, which is not directed to BMP WQV |
| PDA-1B                                      | 0.797          | 1             | 2,893                  |  |
| PDA-2B                                      | 0.319          | 1             | 1,158                  |  |
| PDA-3B                                      | 0.310          | 1             | 1,125                  |  |
| PDA-4                                       | 0.049          | 1             | 179                    |  |
| <b>Total Required Water Quality Volume:</b> |                |               | <b>8,118</b>           | Cubic Feet   |

### Provided Water Quality Volume:

| Drainage Area/<br>Treatment Train           | BMP                         | Water Quality Volume Provided [CF] |   |
|---|-----------------------------|------------------------------------|---|
| PDA-1A**                                    | Sediment Forebay            | 570                                | **Path and Fire Access not directed to BMP for WQ treatment |
| PDA-1B                                      | WQU-201/202 & Subsurface #1 | 5,089                              |   |
| PDA-2B                                      | WQU-205 & Subsurface #2     | 2,200                              |   |
| PDA-3B                                      | WQU-204 & Subsurface #3     | 1,133                              |   |
| PDA-4                                       | WQU-203                     | 1,089                              |   |
| <b>Total Provided Water Quality Volume:</b> |                             | <b>10,081</b>                      | Cubic Feet  |

**WATER QUALITY VOLUME PROVIDED IS GREATER THAN OR EQUAL TO THE REQUIRED WATER QUALITY VOLUME, THEREFORE PROPOSED STORMWATER MANAGEMENT DESIGN IS IN COMPLIANCE WITH STANDARD 4.**

JOB NO. 2063.27  
JOB: NOVO Riverside Commons

COMPUTED BY: TJM  
DATE: 09/19/23

CHECKED BY: \_\_\_\_\_  
DATE: \_\_\_\_\_



**Step 1: Define Minimum Flow Rate per Water Quality Inlet to Treat Desired Water Quality Volume**

Water quality inlets are sized based on flow rate; therefore expressing Water Quality Volume as a flow rate based on the percentage of cumulative average volume captured ensures systems are sized to achieve the desired Water Quality treatment level.

$Q = (q_u)(A)(WQV)$  where:

Q = peak flow rate associated with first 1.0-inch of runoff [CFS]

$q_u$  = The Peak Discharge [CFS/mi<sup>2</sup>/in] Massachusetts DEP Standard Method to Convert Required Water Quality Volume to a Discharge Rate for Sizing Flow Based Manufactured Proprietary Stormwater Treatment Practices

A = Contributing Drainage Area, Impervious Surface Only [Ac]

WQV = The Water Quality Treatment Depth [In]

| WQI No. | A (Ac) | Tc (Min) | WQV (in) | $q_u$ (csm/in) | Q (cfs) |
|---------|--------|----------|----------|----------------|---------|
| WQU-201 | 0.25   | 6.0      | 1.0      | 774            | 0.30    |
| WQU-202 | 0.50   | 6.0      | 1.0      | 774            | 0.60    |
| WQU-203 | 0.30   | 6.0      | 1.0      | 774            | 0.36    |
| WQU-204 | 0.30   | 6.0      | 1.0      | 774            | 0.36    |
| WQU-205 | 0.33   | 6.0      | 1.0      | 774            | 0.40    |
| Total   | 1.68   | Acres    |          |                |         |

**Step 2: Size Water Quality Inlet as recommended by Manufacturer**

See attached Sizing Report(s) for recommended model(s).

**Step 3: Water Quality Volume Provided by WQI unit(s)**

Total Impervious Area Treated by WQI unit(s): 1.68 Acres  
73,181 SF  
 Treated Water Quality Depth : 1.0 inches  
 (accounted for by Average Water Quality Flow Rate)

**Total Water Quality Volume provided by Water Quality Inlets: 6,098 CF**

JOB NO. 2063.27  
 JOB: NOVO Riverside Commons

COMPUTED BY: TJM  
 DATE: 9/19/202

CHECKED BY: \_\_\_\_\_  
 DATE: \_\_\_\_\_

INSTRUCTIONS:

Non-automated: Mar. 4, 2008

1. Sheet is nonautomated. Print sheet and complete using hand calculations. Column A and B: See MassDEP Structural BMP Table
2. The calculations must be completed using the Column Headings specified in Chart and Not the Excel Column Headings
3. To complete Chart Column D, multiple Column B value within Row x Column C value within Row
4. To complete Chart Column E value, subtract Column D value within Row from Column C within Row
5. Total TSS Removal = Sum All Values in Column D

Location: **CB to WQ (Portions of PDA-1A, 1B & 3B)**

|  | A                              | B                             | C                  | D                    | E                    |
|--|--------------------------------|-------------------------------|--------------------|----------------------|----------------------|
|  | BMP <sup>1</sup>               | TSS Removal Rate <sup>1</sup> | Starting TSS Load* | Amount Removed (B*C) | Remaining Load (C-D) |
| <b>TSS Removal Calculation Worksheet</b> | Deep Sump Catch Basin          | 25%                           | 1.00               | 0.25                 | 0.75                 |
|  | Proprietary Water Quality Unit | 80% (Minimum)                 | 0.75               | 0.60                 | 0.15                 |
|  |                                |                               |                    |                      |                      |
|  |                                |                               |                    |                      |                      |
|  |                                |                               |                    |                      |                      |

**Total TSS Removal =**

**85% (Minimum)**

**Separate Form Needs to be Completed for Each Outlet or BMP Train**

Project: **NOVO Riverside**  
 Prepared By: **TJM**  
 Date: **9/19/23**

\*Equals remaining load from previous BMP (E) which enters the BMP

INSTRUCTIONS:

Non-automated: Mar. 4, 2008

1. Sheet is nonautomated. Print sheet and complete using hand calculations. Column A and B: See MassDEP Structural BMP Table
2. The calculations must be completed using the Column Headings specified in Chart and Not the Excel Column Headings
3. To complete Chart Column D, multiple Column B value within Row x Column C value within Row
4. To complete Chart Column E value, subtract Column D value within Row from Column C within Row
5. Total TSS Removal = Sum All Values in Column D

Location: **WQ (Portions of PDA-1A, 1B, 2B & 3B)**

**TSS Removal Calculation Worksheet**

| A<br>BMP <sup>1</sup>          | B<br>TSS Removal Rate <sup>1</sup> | C<br>Starting TSS Load* | D<br>Amount Removed (B*C) | E<br>Remaining Load (C-D) |
|--------------------------------|------------------------------------|-------------------------|---------------------------|---------------------------|
| Proprietary Water Quality Unit | 80% (Minimum)                      | 1.00                    | 0.80                      | 0.20                      |
|                                |                                    |                         |                           |                           |
|                                |                                    |                         |                           |                           |
|                                |                                    |                         |                           |                           |
|                                |                                    |                         |                           |                           |

**Total TSS Removal =**

**80% (Minimum)**

**Separate Form Needs to be Completed for Each Outlet or BMP Train**

Project: **NOVO Riverside**  
 Prepared By: **TJM**  
 Date: **9/19/23**

\*Equals remaining load from previous BMP (E) which enters the BMP

INSTRUCTIONS:

Non-automated: Mar. 4, 2008

1. Sheet is nonautomated. Print sheet and complete using hand calculations. Column A and B: See MassDEP Structural BMP Table
2. The calculations must be completed using the Column Headings specified in Chart and Not the Excel Column Headings
3. To complete Chart Column D, multiple Column B value within Row x Column C value within Row
4. To complete Chart Column E value, subtract Column D value within Row from Column C within Row
5. Total TSS Removal = Sum All Values in Column D

Location: **Sediment Forebay (Portion of PDA-1A)**

**TSS Removal Calculation Worksheet**

| A<br>BMP <sup>1</sup> | B<br>TSS Removal Rate <sup>1</sup> | C<br>Starting TSS Load* | D<br>Amount Removed (B*C) | E<br>Remaining Load (C-D) |
|-----------------------|------------------------------------|-------------------------|---------------------------|---------------------------|
| Sediment Forebay      | 25% (Minimum)                      | 1.00                    | 0.25                      | 0.75                      |
|                       |                                    |                         |                           |                           |
|                       |                                    |                         |                           |                           |
|                       |                                    |                         |                           |                           |
|                       |                                    |                         |                           |                           |

**Total TSS Removal =**

**25%**

**Separate Form Needs to be Completed for Each Outlet or BMP Train**

Project: **NOVO Riverside**  
 Prepared By: **TJM**  
 Date: **9/19/23**

\*Equals remaining load from previous BMP (E) which enters the BMP

**Project:** NOVO Riverside Commons  
**Location:** Concord, MA  
**Prepared For:** Beals & Thomas / Tom Michalak



**Purpose:** To calculate the water quality flow rate (WQF) over a given site area. In this situation the WQF is derived from the first 1" of runoff from the contributing impervious surface.

**Reference:** Massachusetts Dept. of Environmental Protection Wetlands Program / United States Department of Agriculture Natural Resources Conservation Service TR-55 Manual

**Procedure:** Determine unit peak discharge using Figure 1 or 2. Figure 2 is in tabular form so is preferred. Using the  $t_c$ , read the unit peak discharge ( $q_u$ ) from Figure 1 or Table in Figure 2.  $q_u$  is expressed in the following units: cfs/mi<sup>2</sup>/watershed inches (csm/in).

Compute Q Rate using the following equation:

$$Q = (q_u) (A) (WQV)$$

where:

Q = flow rate associated with first 1" of runoff

$q_u$  = the unit peak discharge, in csm/in.

A = impervious surface drainage area (in square miles)

WQV = water quality volume in watershed inches (1" in this case)

| Structure Name | Impv. (acres) | A (miles <sup>2</sup> ) | $t_c$ (min) | $t_c$ (hr) | WQV (in) | $q_u$ (csm/in.) | Q (cfs) |
|----------------|---------------|-------------------------|-------------|------------|----------|-----------------|---------|
| WQU 201        | 0.10          | 0.0001531               | 5.0         | 0.083      | 1.00     | 795.00          | 0.12    |
| WQU 202        | 0.49          | 0.0007688               | 5.0         | 0.083      | 1.00     | 795.00          | 0.61    |
| WQU 203        | 0.11          | 0.0001734               | 5.0         | 0.083      | 1.00     | 795.00          | 0.14    |
| WQU 204        | 0.22          | 0.0003438               | 5.0         | 0.083      | 1.00     | 795.00          | 0.27    |
| WQU 205        | 0.31          | 0.0004813               | 5.0         | 0.083      | 1.00     | 795.00          | 0.38    |
|                |               |                         |             |            |          |                 |         |
|                |               |                         |             |            |          |                 |         |
|                |               |                         |             |            |          |                 |         |
|                |               |                         |             |            |          |                 |         |
|                |               |                         |             |            |          |                 |         |

The WQf sizing calculation selects the minimum size CDS/Cascade/StormCeptor model capable of operating at the computed WQf peak flowrate prior to bypassing. It assumes free discharge of the WQf through the unit and ignores the routing effect of any upstream storm drain piping. As with all hydrodynamic separators, there will be some impact to the Hydraulic Gradient of the corresponding drainage system, and evaluation of this impact should be considered in the design.

## Brief Stormceptor Sizing Report - WQU 201

| Project Information & Location |                              |                            |                              |
|--------------------------------|------------------------------|----------------------------|------------------------------|
| <b>Project Name</b>            | NOVO Riverside Commons       | <b>Project Number</b>      | 768489                       |
| <b>City</b>                    | Concord                      | <b>State/ Province</b>     | Massachusetts                |
| <b>Country</b>                 | United States of America     | <b>Date</b>                | 8/21/2023                    |
| Designer Information           |                              | EOR Information (optional) |                              |
| <b>Name</b>                    | Jim Lyons                    | <b>Name</b>                | Tom Michalak                 |
| <b>Company</b>                 | Contech Engineered Solutions | <b>Company</b>             | Beals & Thomas Inc           |
| <b>Phone #</b>                 | 413-246-5151                 | <b>Phone #</b>             | 508-366-0560                 |
| <b>Email</b>                   | james.lyons@conteches.com    | <b>Email</b>               | tmichalak@bealsandthomas.com |

### Stormwater Treatment Recommendation

The recommended Stormceptor Model(s) which achieve or exceed the user defined water quality objective for each site within the project are listed in the below Sizing Summary table.

|                                      |          |
|--------------------------------------|----------|
| <b>Site Name</b>                     | WQU 201  |
| <b>Target TSS Removal (%)</b>        | 80       |
| <b>TSS Removal (%) Provided</b>      | 96       |
| <b>Recommended Stormceptor Model</b> | STC 450i |

The recommended Stormceptor Model achieves the water quality objectives based on the selected inputs, historical rainfall records and selected particle size distribution.

| Stormceptor Sizing Summary |                        |
|----------------------------|------------------------|
| Stormceptor Model          | % TSS Removal Provided |
| STC 450i                   | 96                     |
| STC 900                    | 98                     |
| STC 1200                   | 98                     |
| STC 1800                   | 98                     |
| STC 2400                   | 99                     |
| STC 3600                   | 99                     |
| STC 4800                   | 99                     |
| STC 6000                   | 99                     |
| STC 7200                   | 99                     |
| STC 11000                  | 100                    |
| STC 13000                  | 100                    |
| STC 16000                  | 100                    |

| Sizing Details     |               |                                |                 |
|--------------------|---------------|--------------------------------|-----------------|
| Drainage Area      |               | Water Quality Objective        |                 |
| Total Area (acres) | 0.18          | TSS Removal (%)                | 80.0            |
| Imperviousness %   | 56.0          | Runoff Volume Capture (%)      |                 |
| Rainfall           |               | Oil Spill Capture Volume (Gal) |                 |
| Station Name       | BLUE HILL     | Peak Conveyed Flow Rate (CFS)  |                 |
| State/Province     | Massachusetts | Water Quality Flow Rate (CFS)  | 0.12            |
| Station ID #       | 0736          | Up Stream Storage              |                 |
| Years of Records   | 58            | Storage (ac-ft)                | Discharge (cfs) |
| Latitude           | 42°12'44"N    | 0.000                          | 0.000           |
| Longitude          | 71°6'53"W     | Up Stream Flow Diversion       |                 |
|                    |               | Max. Flow to Stormceptor (cfs) |                 |

| Particle Size Distribution (PSD)<br>The selected PSD defines TSS removal |                |                  |
|--|----------------|------------------|
| OK-110   |                |                  |
| Particle Diameter (microns)  | Distribution % | Specific Gravity |
| 1.0  | 0.0            | 2.65             |
| 53.0   | 3.0            | 2.65             |
| 75.0   | 15.0           | 2.65             |
| 88.0   | 25.0           | 2.65             |
| 106.0  | 41.0           | 2.65             |
| 125.0  | 15.0           | 2.65             |
| 150.0  | 1.0            | 2.65             |
| 212.0  | 0.0            | 2.65             |

| Notes  |
|--|
| <ul style="list-style-type: none"> <li>Stormceptor performance estimates are based on simulations using PCSWMM for Stormceptor, which uses the EPA Rainfall and Runoff modules.</li> <li>Design estimates listed are only representative of specific project requirements based on total suspended solids (TSS) removal defined by the selected PSD, and based on stable site conditions only, after construction is completed.</li> <li>For submerged applications or sites specific to spill control, please contact your local Stormceptor representative for further design assistance.</li> </ul> |

For Stormceptor Specifications and Drawings Please Visit:  
<https://www.conteches.com/technical-guides/search?filter=1WBC005EYX>

**CDS ESTIMATED NET ANNUAL SOLIDS LOAD REDUCTION  
BASED ON THE RATIONAL RAINFALL METHOD**

**NOVO RIVERSIDE COMMONS  
CONCORD, MA**

Area **0.49 ac**  
Weighted C **0.9**  
 $t_c$  **5 min**  
CDS Model **2015-4**

Unit Site Designation **WQU 202**  
Rainfall Station # **68**

CDS Treatment Capacity **1.4 cfs**

| <u>Rainfall Intensity<sup>1</sup></u><br>(in/hr)      | <u>Percent Rainfall Volume<sup>1</sup></u> | <u>Cumulative Rainfall Volume</u> | <u>Total Flowrate (cfs)</u> | <u>Treated Flowrate (cfs)</u> | <u>Incremental Removal (%)</u> |
|---|--|-----------------------------------|-----------------------------|-------------------------------|--------------------------------|
| 0.02  | 9.3%                                       | 9.3%                              | 0.01                        | 0.01                          | 9.3                            |
| 0.04  | 9.5%                                       | 18.8%                             | 0.02                        | 0.02                          | 9.5                            |
| 0.06  | 8.7%                                       | 27.5%                             | 0.03                        | 0.03                          | 8.7                            |
| 0.08  | 10.1%                                      | 37.6%                             | 0.04                        | 0.04                          | 10.1                           |
| 0.10  | 7.2%                                       | 44.8%                             | 0.04                        | 0.04                          | 7.2                            |
| 0.12  | 6.0%                                       | 50.8%                             | 0.05                        | 0.05                          | 6.0                            |
| 0.14  | 6.3%                                       | 57.1%                             | 0.06                        | 0.06                          | 6.3                            |
| 0.16  | 5.6%                                       | 62.7%                             | 0.07                        | 0.07                          | 5.5                            |
| 0.18  | 4.7%                                       | 67.4%                             | 0.08                        | 0.08                          | 4.6                            |
| 0.20  | 3.6%                                       | 71.0%                             | 0.09                        | 0.09                          | 3.6                            |
| 0.25  | 8.2%                                       | 79.1%                             | 0.11                        | 0.11                          | 8.0                            |
| 0.50  | 14.9%                                      | 94.0%                             | 0.22                        | 0.22                          | 14.0                           |
| 0.75  | 3.2%                                       | 97.3%                             | 0.33                        | 0.33                          | 2.9                            |
| 1.00  | 1.2%                                       | 98.5%                             | 0.44                        | 0.44                          | 1.1                            |
| 1.50  | 0.7%                                       | 99.2%                             | 0.66                        | 0.66                          | 0.6                            |
| 2.00  | 0.8%                                       | 100.0%                            | 0.88                        | 0.88                          | 0.6                            |
| 0.00  | 0.0%                                       | 100.0%                            | 0.00                        | 0.00                          | 0.0                            |
| 0.00  | 0.0%                                       | 100.0%                            | 0.00                        | 0.00                          | 0.0                            |
| 0.00  | 0.0%                                       | 100.0%                            | 0.00                        | 0.00                          | 0.0                            |
| 0.00  | 0.0%                                       | 100.0%                            | 0.00                        | 0.00                          | 0.0                            |
| 0.00  | 0.0%                                       | 100.0%                            | 0.00                        | 0.00                          | 0.0                            |
|   |  |                                   |                             |                               | 97.8                           |
| Removal Efficiency Adjustment <sup>2</sup> =          |  |                                   |                             |                               | 6.5%                           |
| Predicted % Annual Rainfall Treated =                 |  |                                   |                             |                               | 93.5%                          |
| <b>Predicted Net Annual Load Removal Efficiency =</b> |  |                                   |                             |                               | <b>91.3%</b>                   |

1 - Based on 10 years of rainfall data from NCDC station 736, Blue Hill, Norfolk County, MA

2 - Reduction due to use of 60-minute data for a site that has a time of concentration less than 30-minutes.

**CDS ESTIMATED NET ANNUAL SOLIDS LOAD REDUCTION  
BASED ON THE RATIONAL RAINFALL METHOD**

**NOVO RIVERSIDE COMMONS  
CONCORD, MA**

Area **0.11 ac**  
Weighted C **0.9**  
 $t_c$  **5 min**  
CDS Model **1515-3**

Unit Site Designation **WQU 203**  
Rainfall Station # **68**

CDS Treatment Capacity **1.0 cfs**

| <u>Rainfall Intensity<sup>1</sup></u><br>(in/hr)      | <u>Percent Rainfall Volume<sup>1</sup></u> | <u>Cumulative Rainfall Volume</u> | <u>Total Flowrate (cfs)</u> | <u>Treated Flowrate (cfs)</u> | <u>Incremental Removal (%)</u> |
|---|--|-----------------------------------|-----------------------------|-------------------------------|--------------------------------|
| 0.02  | 9.3%                                       | 9.3%                              | 0.00                        | 0.00                          | 9.3                            |
| 0.04  | 9.5%                                       | 18.8%                             | 0.00                        | 0.00                          | 9.5                            |
| 0.06  | 8.7%                                       | 27.5%                             | 0.01                        | 0.01                          | 8.7                            |
| 0.08  | 10.1%                                      | 37.6%                             | 0.01                        | 0.01                          | 10.1                           |
| 0.10  | 7.2%                                       | 44.8%                             | 0.01                        | 0.01                          | 7.2                            |
| 0.12  | 6.0%                                       | 50.8%                             | 0.01                        | 0.01                          | 6.0                            |
| 0.14  | 6.3%                                       | 57.1%                             | 0.01                        | 0.01                          | 6.3                            |
| 0.16  | 5.6%                                       | 62.7%                             | 0.02                        | 0.02                          | 5.6                            |
| 0.18  | 4.7%                                       | 67.4%                             | 0.02                        | 0.02                          | 4.7                            |
| 0.20  | 3.6%                                       | 71.0%                             | 0.02                        | 0.02                          | 3.6                            |
| 0.25  | 8.2%                                       | 79.1%                             | 0.02                        | 0.02                          | 8.2                            |
| 0.50  | 14.9%                                      | 94.0%                             | 0.05                        | 0.05                          | 14.8                           |
| 0.75  | 3.2%                                       | 97.3%                             | 0.07                        | 0.07                          | 3.2                            |
| 1.00  | 1.2%                                       | 98.5%                             | 0.10                        | 0.10                          | 1.2                            |
| 1.50  | 0.7%                                       | 99.2%                             | 0.15                        | 0.15                          | 0.7                            |
| 2.00  | 0.8%                                       | 100.0%                            | 0.20                        | 0.20                          | 0.7                            |
| 0.00  | 0.0%                                       | 100.0%                            | 0.00                        | 0.00                          | 0.0                            |
| 0.00  | 0.0%                                       | 100.0%                            | 0.00                        | 0.00                          | 0.0                            |
| 0.00  | 0.0%                                       | 100.0%                            | 0.00                        | 0.00                          | 0.0                            |
| 0.00  | 0.0%                                       | 100.0%                            | 0.00                        | 0.00                          | 0.0                            |
| 0.00  | 0.0%                                       | 100.0%                            | 0.00                        | 0.00                          | 0.0                            |
|   |  |                                   |                             |                               | 99.6                           |
| Removal Efficiency Adjustment <sup>2</sup> =          |  |                                   |                             |                               | 6.5%                           |
| Predicted % Annual Rainfall Treated =                 |  |                                   |                             |                               | 93.5%                          |
| <b>Predicted Net Annual Load Removal Efficiency =</b> |  |                                   |                             |                               | <b>93.2%</b>                   |

1 - Based on 10 years of rainfall data from NCDC station 736, Blue Hill, Norfolk County, MA

2 - Reduction due to use of 60-minute data for a site that has a time of concentration less than 30-minutes.

## Brief Stormceptor Sizing Report - WQU 204

| Project Information & Location |                              |                            |                              |
|--------------------------------|------------------------------|----------------------------|------------------------------|
| <b>Project Name</b>            | NOVO Riverside Commons       | <b>Project Number</b>      | 768489                       |
| <b>City</b>                    | Concord                      | <b>State/ Province</b>     | Massachusetts                |
| <b>Country</b>                 | United States of America     | <b>Date</b>                | 8/21/2023                    |
| Designer Information           |                              | EOR Information (optional) |                              |
| <b>Name</b>                    | Jim Lyons                    | <b>Name</b>                | Tom Michalak                 |
| <b>Company</b>                 | Contech Engineered Solutions | <b>Company</b>             | Beals & Thomas Inc           |
| <b>Phone #</b>                 | 413-246-5151                 | <b>Phone #</b>             | 508-366-0560                 |
| <b>Email</b>                   | james.lyons@conteches.com    | <b>Email</b>               | tmichalak@bealsandthomas.com |

### Stormwater Treatment Recommendation

The recommended Stormceptor Model(s) which achieve or exceed the user defined water quality objective for each site within the project are listed in the below Sizing Summary table.

|                                      |          |
|--------------------------------------|----------|
| <b>Site Name</b>                     | WQU 204  |
| <b>Target TSS Removal (%)</b>        | 80       |
| <b>TSS Removal (%) Provided</b>      | 93       |
| <b>Recommended Stormceptor Model</b> | STC 450i |

The recommended Stormceptor Model achieves the water quality objectives based on the selected inputs, historical rainfall records and selected particle size distribution.

| Stormceptor Sizing Summary |                        |
|----------------------------|------------------------|
| Stormceptor Model          | % TSS Removal Provided |
| STC 450i                   | 93                     |
| STC 900                    | 96                     |
| STC 1200                   | 96                     |
| STC 1800                   | 97                     |
| STC 2400                   | 98                     |
| STC 3600                   | 98                     |
| STC 4800                   | 99                     |
| STC 6000                   | 99                     |
| STC 7200                   | 99                     |
| STC 11000                  | 99                     |
| STC 13000                  | 99                     |
| STC 16000                  | 99                     |

| Sizing Details     |               |                                |                 |
|--------------------|---------------|--------------------------------|-----------------|
| Drainage Area      |               | Water Quality Objective        |                 |
| Total Area (acres) | 0.29          | TSS Removal (%)                | 80.0            |
| Imperviousness %   | 76.0          | Runoff Volume Capture (%)      |                 |
| Rainfall           |               | Oil Spill Capture Volume (Gal) |                 |
| Station Name       | BLUE HILL     | Peak Conveyed Flow Rate (CFS)  |                 |
| State/Province     | Massachusetts | Water Quality Flow Rate (CFS)  | 0.27            |
| Station ID #       | 0736          | Up Stream Storage              |                 |
| Years of Records   | 58            | Storage (ac-ft)                | Discharge (cfs) |
| Latitude           | 42°12'44"N    | 0.000                          | 0.000           |
| Longitude          | 71°6'53"W     | Up Stream Flow Diversion       |                 |
|                    |               | Max. Flow to Stormceptor (cfs) |                 |

| Particle Size Distribution (PSD)<br>The selected PSD defines TSS removal |                |                  |
|--|----------------|------------------|
| OK-110   |                |                  |
| Particle Diameter (microns)  | Distribution % | Specific Gravity |
| 1.0  | 0.0            | 2.65             |
| 53.0   | 3.0            | 2.65             |
| 75.0   | 15.0           | 2.65             |
| 88.0   | 25.0           | 2.65             |
| 106.0  | 41.0           | 2.65             |
| 125.0  | 15.0           | 2.65             |
| 150.0  | 1.0            | 2.65             |
| 212.0  | 0.0            | 2.65             |

| Notes  |
|--|
| <ul style="list-style-type: none"> <li>Stormceptor performance estimates are based on simulations using PCSWMM for Stormceptor, which uses the EPA Rainfall and Runoff modules.</li> <li>Design estimates listed are only representative of specific project requirements based on total suspended solids (TSS) removal defined by the selected PSD, and based on stable site conditions only, after construction is completed.</li> <li>For submerged applications or sites specific to spill control, please contact your local Stormceptor representative for further design assistance.</li> </ul> |

For Stormceptor Specifications and Drawings Please Visit:  
<https://www.conteches.com/technical-guides/search?filter=1WBC005EYX>

## Brief Stormceptor Sizing Report - WQU 205

| Project Information & Location |                              |                            |                              |
|--------------------------------|------------------------------|----------------------------|------------------------------|
| <b>Project Name</b>            | NOVO Riverside Commons       | <b>Project Number</b>      | 768489                       |
| <b>City</b>                    | Concord                      | <b>State/ Province</b>     | Massachusetts                |
| <b>Country</b>                 | United States of America     | <b>Date</b>                | 8/21/2023                    |
| Designer Information           |                              | EOR Information (optional) |                              |
| <b>Name</b>                    | Jim Lyons                    | <b>Name</b>                | Tom Michalak                 |
| <b>Company</b>                 | Contech Engineered Solutions | <b>Company</b>             | Beals & Thomas Inc           |
| <b>Phone #</b>                 | 413-246-5151                 | <b>Phone #</b>             | 508-366-0560                 |
| <b>Email</b>                   | james.lyons@conteches.com    | <b>Email</b>               | tmichalak@bealsandthomas.com |

### Stormwater Treatment Recommendation

The recommended Stormceptor Model(s) which achieve or exceed the user defined water quality objective for each site within the project are listed in the below Sizing Summary table.

|                                      |          |
|--------------------------------------|----------|
| <b>Site Name</b>                     | WQU 205  |
| <b>Target TSS Removal (%)</b>        | 80       |
| <b>TSS Removal (%) Provided</b>      | 91       |
| <b>Recommended Stormceptor Model</b> | STC 450i |

The recommended Stormceptor Model achieves the water quality objectives based on the selected inputs, historical rainfall records and selected particle size distribution.

| Stormceptor Sizing Summary |                        |
|----------------------------|------------------------|
| Stormceptor Model          | % TSS Removal Provided |
| STC 450i                   | 91                     |
| STC 900                    | 95                     |
| STC 1200                   | 95                     |
| STC 1800                   | 96                     |
| STC 2400                   | 97                     |
| STC 3600                   | 97                     |
| STC 4800                   | 98                     |
| STC 6000                   | 98                     |
| STC 7200                   | 99                     |
| STC 11000                  | 99                     |
| STC 13000                  | 99                     |
| STC 16000                  | 99                     |

| Sizing Details       |               |                                 |                 |
|----------------------|---------------|---------------------------------|-----------------|
| <b>Drainage Area</b> |               | <b>Water Quality Objective</b>  |                 |
| Total Area (acres)   | 0.49          | TSS Removal (%)                 | 80.0            |
| Imperviousness %     | 63.0          | Runoff Volume Capture (%)       |                 |
| <b>Rainfall</b>      |               | Oil Spill Capture Volume (Gal)  |                 |
| Station Name         | BLUE HILL     | Peak Conveyed Flow Rate (CFS)   |                 |
| State/Province       | Massachusetts | Water Quality Flow Rate (CFS)   | 0.38            |
| Station ID #         | 0736          | <b>Up Stream Storage</b>        |                 |
| Years of Records     | 58            | Storage (ac-ft)                 | Discharge (cfs) |
| Latitude             | 42°12'44"N    | 0.000                           | 0.000           |
| Longitude            | 71°6'53"W     | <b>Up Stream Flow Diversion</b> |                 |
|                      |               | Max. Flow to Stormceptor (cfs)  |                 |

| Particle Size Distribution (PSD)<br>The selected PSD defines TSS removal |                |                  |
|--|----------------|------------------|
| OK-110   |                |                  |
| Particle Diameter (microns)  | Distribution % | Specific Gravity |
| 1.0  | 0.0            | 2.65             |
| 53.0   | 3.0            | 2.65             |
| 75.0   | 15.0           | 2.65             |
| 88.0   | 25.0           | 2.65             |
| 106.0  | 41.0           | 2.65             |
| 125.0  | 15.0           | 2.65             |
| 150.0  | 1.0            | 2.65             |
| 212.0  | 0.0            | 2.65             |

| Notes  |
|--|
| <ul style="list-style-type: none"> <li>Stormceptor performance estimates are based on simulations using PCSWMM for Stormceptor, which uses the EPA Rainfall and Runoff modules.</li> <li>Design estimates listed are only representative of specific project requirements based on total suspended solids (TSS) removal defined by the selected PSD, and based on stable site conditions only, after construction is completed.</li> <li>For submerged applications or sites specific to spill control, please contact your local Stormceptor representative for further design assistance.</li> </ul> |

For Stormceptor Specifications and Drawings Please Visit:  
<https://www.conteches.com/technical-guides/search?filter=1WBC005EYX>



## Sediment Forebay Sizing

**Design Requirement:**

Min. Storage Volume = 0.1-inch per impervious acre tributary to BMP  
(per Volume 2, Chapter 2, p.13 of the 2008 MA DEP Stormwater Management Handbook)

**Forebay X**

**Required Volume:**

Tributary Impervious Area = **0.500** Acres  
Required Storage Volume = **182** CF

**Provided Volume:**

|           |           | STORAGE (Cubic Feet) |                      |
|-----------|-----------|----------------------|----------------------|
| Elevation | Area (SF) | INTERVAL             | CUMULATIVE           |
| 121.7     | 600       | 0                    | 0                    |
| 122.0     | 1,000     | 240                  | 240                  |
| 122.3     | 1,200     | 330                  | <b><u>570</u></b> CF |

---

JOB NO. 2063.27

JOB: NOVO Riverside Commons

COMPUTED BY: TJM

DATE: 09/18/23

CHECKED BY: \_\_\_\_\_

DATE: \_\_\_\_\_

**Median Stone Sizing:**

$$D_{50} = 0.2D_0 \left( \frac{Q}{\sqrt{gD_0}} \right)^{0.14} \left( \frac{D_0}{TW} \right)$$

Where:

$D_0$  = Maximum Inside Pipe Diameter (ft)

$D_{50}$  = Median Riprap Diameter (ft)

$Q$  = Peak Discharge Rate from Hydraulic Design (cfs)

$TW$  = Tailwater Depth (ft); (Use  $0.4D_0$  if  $TW$  is unknown, max  $1.0D_0$ )

$g$  = Gravitational Acceleration Constant =  $32.2 \text{ ft/s}^2$

**Apron Sizing:**

| $D_{50}$<br>[In] | Apron<br>Length<br>(L) [ft] | Apron<br>Depth<br>[In] | Apron<br>Width At<br>Beginning | Apron<br>Width At<br>End |
|------------------|-----------------------------|------------------------|--------------------------------|--------------------------|
| 5                | $4D_0$                      | $3.5D_{50}$            | $3D_0$                         | $3D_0 + \frac{2}{3}L$    |
| 6                | $4D_0$                      | $3.3D_{50}$            | $3D_0$                         | $3D_0 + \frac{2}{3}L$    |
| 10               | $5D_0$                      | $2.4D_{50}$            | $3D_0$                         | $3D_0 + \frac{2}{3}L$    |
| 14               | $6D_0$                      | $2.2D_{50}$            | $3D_0$                         | $3D_0 + \frac{2}{3}L$    |
| 20               | $7D_0$                      | $2.0D_{50}$            | $3D_0$                         | $3D_0 + \frac{2}{3}L$    |
| 22               | $8D_0$                      | $2.0D_{50}$            | $3D_0$                         | $3D_0 + \frac{2}{3}L$    |

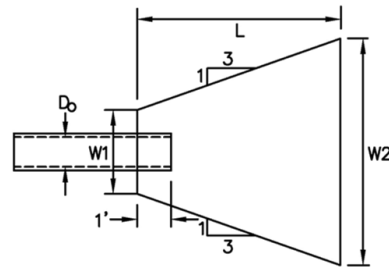

| FLARED END SECTION | PIPE DIAMETER ( $D_0$ ) (FEET) | 25-YEAR STORM FLOW (Q) (CFS±) | TAILWATER (TW) [ft] | MEDIAN STONE DIAMETER ( $D_{50}$ ) (INCHES) | APRON LENGTH (L) (FEET) | APRON DEPTH [In] | APRON WIDTH AT BEGINNING ( $W_1$ ) [ft] | APRON WIDTH AT END ( $W_2$ ) [ft] |
|--------------------|--------------------------------|-------------------------------|---------------------|---|-------------------------|------------------|---|-----------------------------------|
| FE-201             | 1.0                            | 6.50                          | 0.4                 | 10  | 5.00                    | 24               | 3.0                                     | 6.3                               |
| FE-202             | 1.0                            | 1.90                          | 0.4                 | 5   | 4.00                    | 17.5             | 3.0                                     | 5.7                               |
| FE-203             | 1.0                            | 3.50                          | 0.4                 | 5   | 4.00                    | 17.5             | 3                                       | 5.7                               |
| FE-205             | 3.0                            | 37.38                         | 1.2                 | 6   | 12.00                   | 19.8             | 9                                       | 17.0                              |

**Notes**

[1] Calculations performed in accordance with Hydraulic Engineering Circular No. 14, Third Edition; Hydraulic Design of Energy Dissipaters for Culverts and Channels, dated July 2006.

[2] Pipe shall extend 1 foot into riprap.

[3] For maximum pipe size of 60".

JOB NO. 2063.27  
JOB: NOVO Riverside Commons

COMPUTED BY: TJM  
DATE: 09/19/23

CHECKED BY: \_\_\_\_\_  
DATE: \_\_\_\_\_

**Attachment 6**  
**Site Owner's Manual**

---

# Site Owner's Manual

## NOVO RIVERSIDE COMMONS

**292 & 294 Baker Avenue  
Concord, Massachusetts**

*Prepared for:*  
**Taurus Investment Holdings, LLC  
Two International Place  
Boston, MA 02110**

*Prepared by:*



**September 19, 2023**

## TABLE OF CONTENTS

|   |            |
|---|------------|
| <b>1.0 INTRODUCTION .....</b>   | <b>1-1</b> |
| <b>2.0 SITE OWNER'S AGREEMENT.....</b>                                      | <b>2-1</b> |
| 2.1 OPERATION AND MAINTENANCE COMPLIANCE STATEMENT.....                     | 2-1        |
| 2.2 STORMWATER MAINTENANCE EASEMENTS .....                                  | 2-1        |
| 2.3 RECORD KEEPING .....  | 2-1        |
| 2.4 TRAINING .....  | 2-2        |
| <b>3.0 LONG-TERM POLLUTION PREVENTION PLAN .....</b>                        | <b>3-1</b> |
| 3.1 STORAGE OF MATERIALS AND WASTE .....                                    | 3-1        |
| 3.2 VEHICLE WASHING .....   | 3-1        |
| 3.3 ROUTINE INSPECTIONS AND MAINTENANCE OF STORMWATER BMPs.....             | 3-1        |
| 3.4 SPILL PREVENTION AND RESPONSE.....                                      | 3-1        |
| 3.5 MAINTENANCE OF LAWNS, GARDENS, AND OTHER LANDSCAPED AREAS.....          | 3-2        |
| 3.6 STORAGE AND USE OF FERTILIZERS, HERBICIDES, AND PESTICIDES.....         | 3-2        |
| 3.7 PET WASTE MANAGEMENT.....   | 3-2        |
| 3.8 OPERATION AND MANAGEMENT OF SEPTIC SYSTEMS .....                        | 3-2        |
| 3.9 SNOW AND DEICING CHEMICAL MANAGEMENT .....                              | 3-2        |
| 3.10 NUTRIENT MANAGEMENT PLAN.....  | 3-2        |
| <b>4.0 LONG-TERM OPERATION AND MAINTENANCE PLAN .....</b>                   | <b>4-1</b> |
| 4.1 STORMWATER MANAGEMENT SYSTEM COMPONENTS.....                            | 4-1        |
| 4.2 INSPECTION AND MAINTENANCE SCHEDULES .....                              | 4-1        |
| 4.2.1 <i>General Maintenance for Mosquito Control</i> .....                 | 4-1        |
| 4.3 .....   | 4-1        |
| 4.3.1 <i>Deep Sump and Hooded Catch Basins</i> .....                        | 4-1        |
| 4.3.2 <i>Area Drains</i> .....  | 4-2        |
| 4.3.3 <i>Sediment Forebays</i> .....  | 4-2        |
| 4.3.4 <i>Proprietary Separators</i> .....                                   | 4-2        |
| 4.3.5 <i>Subsurface Infiltration Systems &amp; Compensation Areas</i> ..... | 4-3        |
| 4.3.6 <i>Stormwater Outfalls</i> .....                                      | 4-3        |
| 4.3.7 <i>Street Sweeping</i> .....  | 4-3        |
| 4.4 ESTIMATED OPERATION AND MAINTENANCE BUDGET .....                        | 4-3        |
| 4.5 PUBLIC SAFETY FEATURES .....  | 4-4        |

## FIGURES

FIGURE 1: SITE PLAN

## APPENDICES

APPENDIX A: OPERATION AND MAINTENANCE LOG

APPENDIX B: LIST OF EMERGENCY CONTACTS

APPENDIX C: PROPRIETARY SEPARATOR TECHNICAL MANUAL

## 1.0 INTRODUCTION

The Site Owner's Manual complies with the Long-Term Pollution Prevention Plan (Standard 4) and the Long-Term Operation and Maintenance Plan (Standard 9) requirements of the 2008 Massachusetts Department of Environmental Protection (DEP) Stormwater Handbook. The Manual outlines source control and pollution prevention measures and maintenance requirements of stormwater best management practices (BMPs) associated with the proposed development.

## 2.0 SITE OWNER'S AGREEMENT

### 2.1 Operation and Maintenance Compliance Statement

Site Owner: Taurus Investment Holdings, LLC  
Two International Place, Boston, MA 02110

Responsible Party: Taurus Investment Holdings, LLC  
Two International Place, Boston, MA 02110

Taurus Investment Holdings, LLC or their successors shall maintain ownership of the on-site stormwater management system as well as the responsibility for operation and maintenance during the post-development stages of the project. The site has been inspected for erosion and appropriate measures have been taken to permanently stabilize any eroded areas. All aspects of stormwater best management practices (BMPs) have been inspected for damage, wear and malfunction, and appropriate steps have been taken to repair or replace the system or portions of the system so that the stormwater at the site may be managed in accordance with the Stormwater Management Standards. Future responsible parties shall be notified of their continuing legal responsibility to operate and maintain the BMPs. The operation and maintenance plan for the stormwater BMPs is being implemented.

\_\_\_\_\_  
Responsible Party Signature

\_\_\_\_\_  
Date

### 2.2 Stormwater Maintenance Easements

There are no off-site areas utilized for stormwater control, therefore no stormwater management easements are required. The Site Owner will have access to all stormwater practices for inspection and maintenance, including direct maintenance access by heavy equipment to structures requiring regular maintenance.

### 2.3 Record Keeping

The Site Owner shall maintain a rolling log in which all inspections and maintenance activities for the past three years shall be recorded. The Operation and Maintenance Log includes information pertaining to inspections, repairs, and disposal relevant to the project's stormwater management system. The Log is located in Appendix A.

The Operation and Maintenance Log shall be made available to the Conservation Commission and the DEP upon request. The Conservation Commission and the DEP shall be allowed to enter and inspect the premises to evaluate and ensure that the responsible party complies with the maintenance requirements for each BMP.

## 2.4 Training

Employees involved in grounds maintenance and emergency response will be educated on the general concepts of stormwater management and groundwater protection. The Site Owner's Manual will be reviewed with the maintenance staff. The staff will be trained on the proper course of action for specific events expected to be incurred during routine maintenance or emergency situations.

### **3.0 LONG-TERM POLLUTION PREVENTION PLAN**

In compliance with Standard 4 of the 2008 DEP Stormwater Management Handbook, this section outlines source control and pollution prevention measures to be employed on-site after construction.

#### **3.1 Storage of Materials and Waste**

The site shall be kept clear of trash and debris at all times. Certain materials and waste products shall be stored inside or outside upon an impervious surface and covered, as required by local and state regulations.

#### **3.2 Vehicle Washing**

No commercial vehicle washing shall take place on site.

#### **3.3 Routine Inspections and Maintenance of Stormwater BMPs**

See Section 4.0 Long-Term Operation and Maintenance Plan, for routine inspection and maintenance requirements for all proposed stormwater BMPs.

#### **3.4 Spill Prevention and Response**

A contingency plan shall be implemented to address the spill or release of petroleum products and hazardous materials and will include the following measures:

1. Equipment necessary to quickly attend to inadvertent spills or leaks shall be stored on-site in a secure but accessible location. Such equipment shall include but not be limited to the following: safety goggles, chemically resistant gloves and overshoe boots, water and chemical fire extinguishers, sand and shovels, suitable absorbent materials, storage containers and first aid equipment (i.e. Indian Valley Industries, Inc. 55-gallon Spill Containment kit or approved equivalent).
2. Spills or leaks shall be treated properly according to material type, volume of spillage and location of spill. Mitigation shall include preventing further spillage, containing the spilled material in the smallest practical area, removing spilled material in a safe and environmentally-friendly manner, and remediation of any damage to the environment.
3. For large spills, Massachusetts DEP Hazardous Waste Incident Response Group shall be notified immediately at 888-304-1133 and an emergency response contractor shall be consulted.

### **3.5 Maintenance of Lawns, Gardens, and other Landscaped Areas**

Lawns, gardens, and other landscaped areas shall be maintained regularly by the site owner. Vegetated and landscaped BMPs will be maintained as outlined in Section 4.0.

### **3.6 Storage and Use of Fertilizers, Herbicides, and Pesticides**

All fertilizers, herbicides, and pesticides shall be stored in accordance with local, state, and federal regulations. The application rate and use of fertilizers, herbicides, and pesticides on the site shall at no time exceed local, state, or federal specifications.

### **3.7 Pet Waste Management**

Pet owners shall be required to pick up after their animals and dispose of waste in the trash.

### **3.8 Operation and Management of Septic Systems**

The proposed development will be serviced by Town sewer and there are no proposed septic systems.

### **3.9 Snow and Deicing Chemical Management**

Snow removal and use of deicing chemicals at the proposed development shall comply with the following requirements:

- Plowed snow shall be placed in the areas designated on the site plans, outside of wetland boundaries and stormwater best management practices, and removed from the premises, as needed. The following maintenance measures shall be undertaken at all snow disposal sites:
  - Debris shall be cleared from an area prior to using it for snow disposal.
  - Debris and accumulated sediments shall be cleared from the site and properly disposed of at the end of the snow season and no later than May 15.
- In accordance with the Massachusetts General Laws, Chapter 85, Section 7A, salt and other de-icing chemicals will be stored at an indoor location. Salt and other deicing chemicals shall be stored in accordance with Massachusetts General Law.
- Sand piles shall be contained and stabilized to prevent the discharge of sand to wetlands or water bodies, and, where feasible, covered.
- Salt storage piles shall be located outside of the 100-year floodplain.
- The application of salt on the proposed parking areas and driveway shall at no time exceed state or local requirements.

### **3.10 Nutrient Management Plan**

A nutrient management plan is required if a Total Maximum Daily Load (TMDL) has been developed that indicates that use of fertilizers containing nutrients or other specific pollutants must be reduced. The proposed project is located within the Concord

(SuAsCo) Watershed. There are no TMDLs issued for the waterbodies directly downstream of the proposed project.

## 4.0 LONG-TERM OPERATION AND MAINTENANCE PLAN

This section outlines the stormwater best management practices (BMPs) associated with the proposed stormwater management system and identifies the long-term inspection and maintenance requirements for each BMP.

### 4.1 Stormwater Management System Components

The following table outlines the type and quantity of the BMPs and their general location. Please reference the site plan(s) provided in the Figures section for exact location. All basins are accessible for maintenance from either the development driveway or parking areas.

| BMP Type                        | Quantity | Location                                 |
|---------------------------------|----------|--|
| Catch Basins                    | 7        | Throughout paved parking/driveway areas. |
| Area Drains                     | 1        | Grass/landscape areas.                   |
| Water Quality Units             | 5        | Throughout paved parking/driveway areas. |
| Subsurface Infiltration Systems | 3        | East of #292, West and Northwest of #294 |
| Subsurface Compensation Areas   | 2        | West of #294                             |

### 4.2 Inspection and Maintenance Schedules

#### 4.2.1 General Maintenance for Mosquito Control

If necessary to minimize mosquito breeding, a licensed pesticide applicator shall apply larvicides, such as *Bacillus sphaericus* (Bs) to all catch basins sumps, and water quality inlets. Larvicides shall be applied in compliance with all pesticide label requirements, and will be applied during or immediately after wet weather, unless the product used can withstand extended dry periods. Ensure all manhole covers, and inspection ports are secure to reduce the likelihood of mosquitoes laying eggs in standing water.

### 4.3

#### 4.3.1 Deep Sump and Hooded Catch Basins

Catch basins shall be inspected four times per year, including after the foliage season. Other inspection and maintenance requirements include:

- Units shall be cleaned (organic material, sediment and hydrocarbons removed) four times per year or whenever the depth of deposits is

greater than or equal to one half the depth from the bottom of the invert of the lowest pipe in the basin.

- Cleanout shall always occur after street sweeping.
- If any evidence of hydrocarbons is found during inspection, the material shall be immediately removed using absorbent pads or other suitable measures and disposed of legally.
- Remove other accumulated debris as necessary.
- Transport and disposal of accumulated sediment off-site shall be in accordance with applicable local, state and federal guidelines and regulations.

#### 4.3.2 Area Drains

Area drains shall be inspected and/or cleaned at least once per year.

#### 4.3.3 Sediment Forebays

Sediment forebays shall be inspected monthly and cleaned out at least four times per year or when sediment depth is 0.5 feet, whichever is more frequent. Other inspection and maintenance requirements include:

- Vegetation shall be maintained at a height between 3 and 6 inches.
- Any erosion observed shall be repaired as needed.
- After maintenance, the forebay floor and sidewalls shall be stabilized to prevent the discharge of sediment.
- Damaged vegetation shall be replaced by either reseeding or resodding.
  - If reseeding, hydroseeding with a tackifier or blanket (or similar practice) shall be employed to prevent scour within the forebay.

#### 4.3.4 Proprietary Separators

Maintenance of proprietary separators shall be performed according the recommendations set forth by the manufacturer (see Appendix C. Proprietary Separator Technical Manual for complete installation, operation and maintenance procedures). Inspection and maintenance procedures for proprietary devices are provided below:

- Units shall be inspected post-construction, prior to being put into service.
- Units shall be inspected not less than twice per year following installation and no less than once per year thereafter.
- Units shall be inspected immediately after any oil, fuel or chemical spill.
- All inspections shall include checking the oil level and sediment depth in the unit.

- Removal of sediments/oils shall occur per manufacturer recommendations.
- A licensed waste management company shall remove captured petroleum waste products from any oil, chemical or fuel spills and dispose.
- OSHA confined space entry protocols shall be followed if entry into the unit is required.

**4.3.5 Subsurface Infiltration Systems & Compensation Areas**

Subsurface infiltration and Compensation areas shall be inspected twice per year. The inlets shall be inspected, and all debris that may clog the system shall be removed.

**4.3.6 Stormwater Outfalls**

Flared end sections and associated riprap spillways shall be inspected at least once per year and after major storm events (rainfall totals greater than 2.5 inches in 24 hours) to ensure that the stability of the outlet area is maintained. The outfall area shall be kept clear of debris such as trash, branches, and sediment. Repairs shall be made immediately if riprap displacement or downstream channel scour is observed.

**4.3.7 Street Sweeping**

The TSS removal credit is dependent on the type of street sweeper used and the frequency that sweeping occurs (see table below). Street sweeping shall occur primarily in spring and fall, and always prior to catch basin cleanout.

| TSS Removal Credit | Type of Sweeper         |                          |                                   |
|--------------------|-------------------------|--------------------------|-----------------------------------|
|                    | High Efficiency Sweeper | Regenerative Air Sweeper | Mechanical Sweeper (Rotary Broom) |
| 10%                | Monthly                 | Bi-weekly                | Weekly                            |
| 5%                 | Quarterly               | Quarterly                | Monthly                           |
| 0%                 | Less than above         | Less than above          | Less than above                   |

Once removed from paved surfaces, the sweepings shall be handled and disposed of properly, and in compliance with applicable local, state and federal guidelines and regulations.

**4.4 Estimated Operation and Maintenance Budget**

An operations and maintenance budget was prepared to approximate the annual cost of the inspections required in compliance with the DEP Stormwater Management Policy.

The table below estimates the annual cost to inspect and maintain each proposed BMP, based on the requirements in Section 4.2.

| BMP Type                        | # of BMPS | Annual O&M Cost (per BMP) <sup>1</sup> | Total Cost      |
|---------------------------------|-----------|--|-----------------|
| Mosquito Control                | 13        | \$100                                  | \$1,300         |
| Catch Basin                     | 7         | \$400                                  | \$2,800         |
| Area Drain/Drop Inlet           | 1         | \$100                                  | \$100           |
| Sediment Forebay                | 1         | \$500                                  | \$500           |
| Water Quality Unit              | 5         | \$300                                  | \$1,500         |
| Subsurface Infiltration Systems | 3         | \$400                                  | \$1,200         |
| Subsurface Compensation Areas   | 2         | \$400                                  | \$800           |
| Riprap Spillway                 | 4         | \$100                                  | \$400           |
| Street Sweeping <sup>2</sup>    |           | See footnote                           | \$1,500         |
| <b>Total</b>                    |           |  | <b>\$10,100</b> |

#### 4.5 Public Safety Features

Multiple safety measures are proposed to protect the public and prevent pollutant contamination of the stormwater management system and other water resources. Guardrails and existing woodland vegetation along the access driveway will prevent cars from inadvertently detouring down steep side slopes and into adjacent wetlands or stormwater basins. It was designed to ensure protection to the public and prevent pollutant contamination of the stormwater management system and the municipal drainage system.

<sup>1</sup> Annual maintenance cost is based on estimate of the cost to complete all inspection and maintenance measures outlined in Section 4.2. For BMPs that require sediment removal at regular intervals (i.e. every 5 or 10 years), the annual cost includes the annual percentage of that cost.

<sup>2</sup> Sweeping costs are estimated as a range of \$30 - \$50/curb-mile per annual sweeping frequency. See section 4.2.21 for frequency requirements for each type of sweeper. Calculate the range for total annual cost based on curb-miles and frequency and insert it into the table above.

## Figures

---

Figure 1: Site Plan

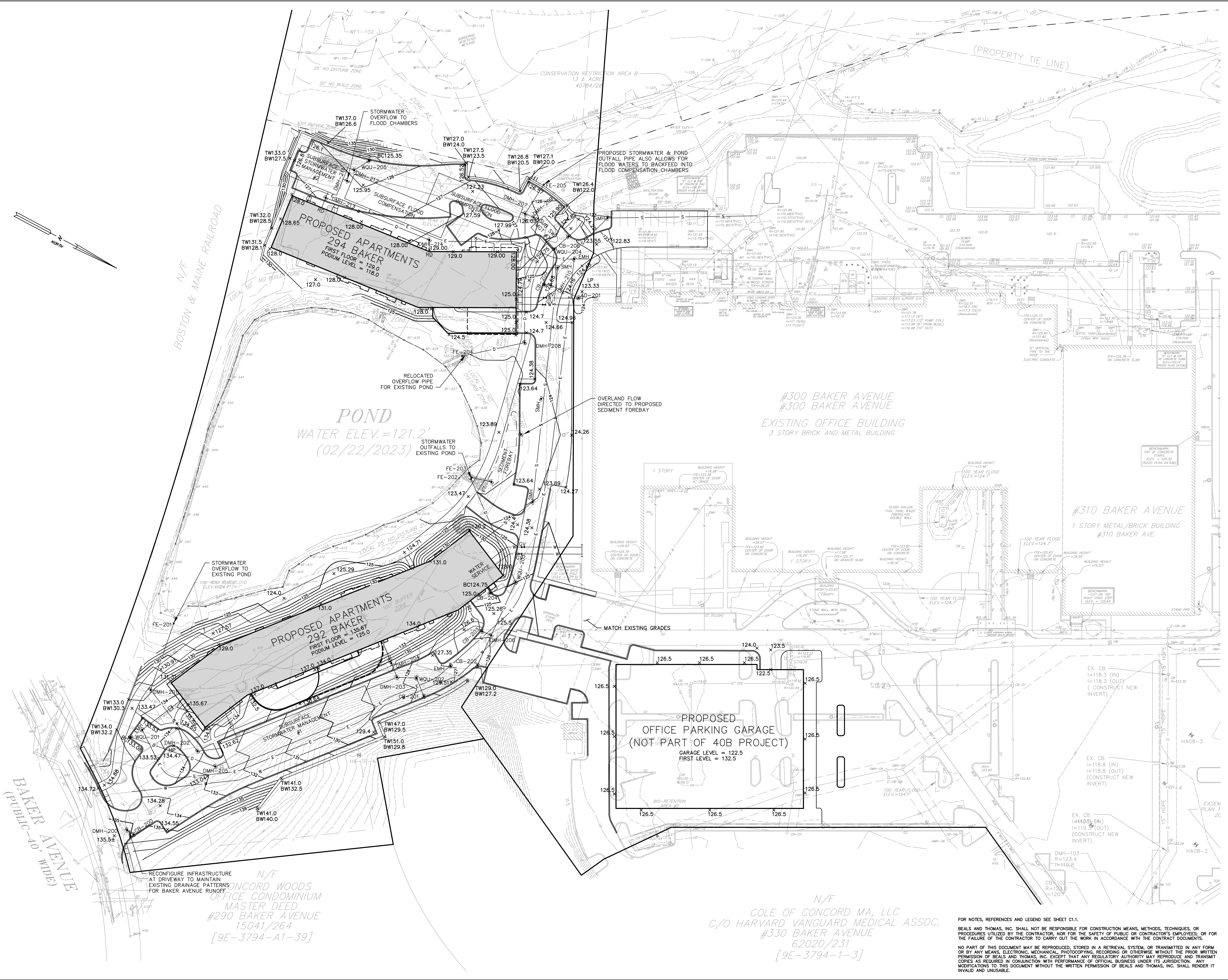
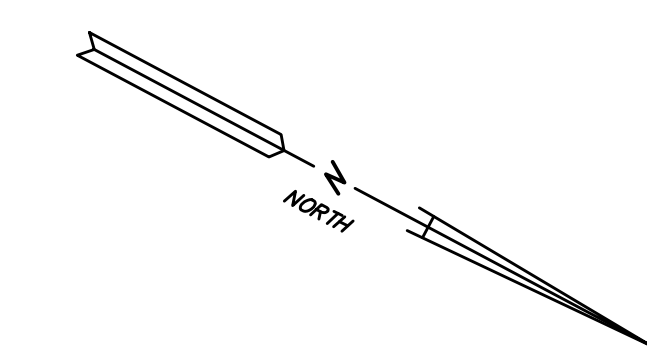

BAKER AVENUE  
(PUBLIC-40' WIDE)

N/F  
CONCORD WOODS  
OFFICE CONDOMINIUM  
MASTER DEED  
#290 BAKER AVENUE  
15041/264  
[9E-3794-A1-39]

N/F  
COLE OF CONCORD MA, LLC  
C/O HARVARD VANGUARD MEDICAL ASSOC.  
#330 BAKER AVENUE  
62020/231  
[9E-3794-1-3]

FOR NOTES, REFERENCES AND LEGEND SEE SHEET C1.1.  
BEALS AND THOMAS, INC. SHALL NOT BE RESPONSIBLE FOR CONSTRUCTION MEANS, METHODS, TECHNIQUES, OR PROCEDURES UTILIZED BY THE CONTRACTOR, NOR FOR THE SAFETY OF PUBLIC OR CONTRACTOR'S EMPLOYEES, OR FOR THE FAILURE OF THE CONTRACTOR TO CARRY OUT THE WORK IN ACCORDANCE WITH THE CONTRACT DOCUMENTS.  
NO PART OF THIS DOCUMENT MAY BE REPRODUCED, STORED IN A RETRIEVAL SYSTEM, OR TRANSMITTED IN ANY FORM OR BY ANY MEANS, ELECTRONIC, MECHANICAL, PHOTOCOPIING, RECORDING OR OTHERWISE, WITHOUT THE PRIOR WRITTEN PERMISSION OF BEALS AND THOMAS, INC. EXCEPT THAT ANY REGULATORY AUTHORITY MAY REPRODUCE AND TRANSMIT COPIES AS REQUIRED IN CONJUNCTION WITH PERFORMANCE OF OFFICIAL BUSINESS UNDER ITS JURISDICTION. ANY MODIFICATIONS TO THIS DOCUMENT WITHOUT THE WRITTEN PERMISSION OF BEALS AND THOMAS, INC. SHALL RENDER IT INVALID AND UNUSABLE.

PREPARED FOR:  
**TAURUS INVESTMENT HOLDINGS, LLC**  
TWO INTERNATIONAL PLACE  
BOSTON, MASSACHUSETTS 02110

**NOT ISSUED FOR CONSTRUCTION**  
COPYRIGHT (C) BY BEALS AND THOMAS, INC. ALL RIGHTS RESERVED.

PREPARED BY:  
**BEALS AND THOMAS**  
BEALS AND THOMAS, INC.  
144 Turnpike Road, Suite 210  
Southborough, Massachusetts 01772-2104  
T 508.366.0560 | www.bealsandthomas.com

|     |            |                     |       |
|-----|------------|---------------------|-------|
| 5   |            |                     |       |
| 4   |            |                     |       |
| 3   |            |                     |       |
| 2   |            |                     |       |
| 1   | 09/19/2023 | SITE OWNER'S MANUAL |       |
| 0   | 05/22/2023 | PEL SUBMISSION      |       |
|     | ISSUE DATE | DESCRIPTION         |       |
| DES | DWN        | CHK'D               | APP'D |

PROJECT:  
**NOVO RIVERSIDE COMMONS 292 & 294 BAKER AVENUE**  
CONCORD, MASSACHUSETTS

SCALE: 1" = 40' DATE: MAY 22, 2023  
METERS  
0 10 20 30 40 50 60 70 80 90 100  
FEET

**GRADING AND DRAINAGE PLAN**  
B+T JOB NO.2063.27  
B+T PLAN NO. 206327P117B-001  
**C31**

## Appendices

---

## Appendix A

---

### Operation and Maintenance Log

## OPERATION AND MAINTENANCE LOG

This template is intended to comply with the operation and maintenance log requirements of the 2008 DEP Stormwater Management Handbook. Copies of this log should be made for all inspections and kept on file for three years from the inspection date.

|  |
|--|
| <b>Name/Company of Inspector:</b>  |
| <b>Date/Time of Inspection:</b>  |
| <b>Weather Conditions:</b><br>(Note current weather and any recent precipitation events) |

| Stormwater BMP | Inspection Observations | Actions Required |
|----------------|-------------------------|------------------|
|                |                         |                  |
|                |                         |                  |
|                |                         |                  |
|                |                         |                  |
|                |                         |                  |
|                |                         |                  |
|                |                         |                  |
|                |                         |                  |

## Appendix B

---

### List of Emergency Contacts

**Dial 911 in cases of emergency**

Massachusetts DEP Hazardous Waste Incident Response Group  
(888) 304-1133

Concord Fire Department  
209 Walden Street  
Concord, MA 01742  
(978) 318-3488  
Fire Chief Thomas M. Judge  
Assistant Fire Chief Walter Latta

Concord Police Department  
219 Walden Street  
Concord, MA 01742  
(978) 318-3400  
Chief Thomas Mulcahy

## Appendix C

---

Proprietary Separator Technical Manual

**Stormceptor<sup>®</sup> STC**  
**Operation and Maintenance Guide**



## Stormceptor Design Notes

- Only the STC 450i is adaptable to function with a catch basin inlet and/or inline pipes.
- Only the Stormceptor models STC 450i to STC 7200 may accommodate multiple inlet pipes.

### Inlet and outlet invert elevation differences are as follows:

| Inlet and Outlet Pipe Invert Elevations Differences |               |                     |                        |
|---|---------------|---------------------|------------------------|
| Inlet Pipe Configuration                            | STC 450i      | STC 900 to STC 7200 | STC 11000 to STC 16000 |
| Single inlet pipe                                   | 3 in. (75 mm) | 1 in. (25 mm)       | 3 in. (75 mm)          |
| Multiple inlet pipes                                | 3 in. (75 mm) | 3 in. (75 mm)       | Only one inlet pipe.   |

### Maximum inlet and outlet pipe diameters:

| Inlet/Outlet Configuration | Inlet Unit<br>STC 450i | In-Line Unit<br>STC 900 to STC 7200 | Series*<br>STC 11000 to STC 16000 |
|----------------------------|------------------------|-------------------------------------|-----------------------------------|
| Straight Through           | 24 inch (600 mm)       | 42 inch (1050 mm)                   | 60 inch (1500 mm)                 |
| Bend (90 degrees)          | 18 inch (450 mm)       | 33 inch (825 mm)                    | 33 inch (825 mm)                  |

- The inlet and in-line Stormceptor units can accommodate turns to a maximum of 90 degrees.
- Minimum distance from top of grade to crown is 2 feet (0.6 m)
- Submerged conditions. A unit is submerged when the standing water elevation at the proposed location of the Stormceptor unit is greater than the outlet invert elevation during zero flow conditions. In these cases, please contact your local Stormceptor representative and provide the following information:
  - Top of grade elevation
  - Stormceptor inlet and outlet pipe diameters and invert elevations
  - Standing water elevation
  - Stormceptor head loss,  $K = 1.3$  (for submerged condition,  $K = 4$ )



## OPERATION AND MAINTENANCE GUIDE

### Table of Content

|  |    |
|--|----|
| 1. About Stormceptor .....                 | 4  |
| 2. Stormceptor Design Overview .....       | 4  |
| 3. Key Operation Features .....            | 6  |
| 4. Stormceptor Product Line.....           | 7  |
| 5. Sizing the Stormceptor System.....      | 10 |
| 6. Spill Controls.....                     | 12 |
| 7. Stormceptor Options.....                | 14 |
| 8. Comparing Technologies .....            | 17 |
| 9. Testing.....                            | 18 |
| 10. Installation .....                     | 18 |
| 11. Stormceptor Construction Sequence..... | 18 |
| 12. Maintenance .....                      | 19 |

# 1. About Stormceptor

The Stormceptor® STC (Standard Treatment Cell) was developed by Imbrium™ Systems to address the growing need to remove and isolate pollution from the storm drain system before it enters the environment. The Stormceptor STC targets hydrocarbons and total suspended solids (TSS) in stormwater runoff. It improves water quality by removing contaminants through the gravitational settling of fine sediments and floatation of hydrocarbons while preventing the re-suspension or scour of previously captured pollutants.

The development of the Stormceptor STC revolutionized stormwater treatment, and created an entirely new category of environmental technology. Protecting thousands of waterways around the world, the Stormceptor System has set the standard for effective stormwater treatment.

## 1.1. Patent Information

The Stormceptor technology is protected by the following patents:

- Australia Patent No. 693,164 • 693,164 • 707,133 • 729,096 • 779401
- Austrian Patent No. 289647
- Canadian Patent No 2,009,208 • 2,137,942 • 2,175,277 • 2,180,305 • 2,180,383 • 2,206,338 • 2,327,768 (Pending)
- China Patent No 1168439
- Denmark DK 711879
- German DE 69534021
- Indonesian Patent No 16688
- Japan Patent No 9-11476 (Pending)
- Korea 10-2000-0026101 (Pending)
- Malaysia Patent No PI9701737 (Pending)
- New Zealand Patent No 314646
- United States Patent No 4,985,148 • 5,498,331 • 5,725,760 • 5,753,115 • 5,849,181 • 6,068,765 • 6,371,690
- Stormceptor OSR Patent Pending • Stormceptor LCS Patent Pending

# 2. Stormceptor Design Overview

## 2.1. Design Philosophy

The patented Stormceptor System has been designed to focus on the environmental objective of providing long-term pollution control. The unique and innovative Stormceptor design allows for continuous positive treatment of runoff during all rainfall events, while ensuring that all captured pollutants are retained within the system, even during intense storm events.

An integral part of the Stormceptor design is PCSWMM for Stormceptor - sizing software developed in conjunction with Computational Hydraulics Inc. (CHI) and internationally acclaimed expert, Dr. Bill James. Using local historical rainfall data and continuous simulation modeling, this software allows a Stormceptor unit to be designed for each individual site and the corresponding water quality objectives.

By using PCSWMM for Stormceptor, the Stormceptor System can be designed to remove a wide range of particles (typically from 20 to 2,000 microns), and can also be customized to remove a specific particle size distribution (PSD). The specified PSD should accurately reflect what is in the stormwater runoff to ensure the device is achieving the desired water quality objective. Since stormwater runoff contains small particles (less than 75 microns), it is important to design a treatment system to remove smaller particles in addition to coarse particles.

## 2.2. Benefits

The Stormceptor System removes free oil and suspended solids from stormwater, preventing spills and non-point source pollution from entering downstream lakes and rivers. The key benefits, capabilities and applications of the Stormceptor System are as follows:

- Provides continuous positive treatment during all rainfall events
- Can be designed to remove over 80% of the annual sediment load
- Removes a wide range of particles
- Can be designed to remove a specific particle size distribution (PSD)
- Captures free oil from stormwater
- Prevents scouring or re-suspension of trapped pollutants
- Pre-treatment to reduce maintenance costs for downstream treatment measures (ponds, swales, detention basins, filters)
- Groundwater recharge protection
- Spills capture and mitigation
- Simple to design and specify
- Designed to your local watershed conditions
- Small footprint to allow for easy retrofit installations
- Easy to maintain (vacuum truck)
- Multiple inlets can connect to a single unit
- Suitable as a bend structure
- Pre-engineered for traffic loading (minimum AASHTO HS-20)
- Minimal elevation drop between inlet and outlet pipes
- Small head loss
- Additional protection provided by an 18" (457 mm) fiberglass skirt below the top of the insert, for the containment of hydrocarbons in the event of a spill.

## 2.3. Environmental Benefit

Freshwater resources are vital to the health and welfare of their surrounding communities. There is increasing public awareness, government regulations and corporate commitment to reducing the pollution entering our waterways. A major source of this pollution originates from stormwater runoff from urban areas. Rainfall runoff carries oils, sediment and other contaminants from roads and parking lots discharging directly into our streams, lakes and coastal waterways.

The Stormceptor System is designed to isolate contaminants from getting into the natural environment. The Stormceptor technology provides protection for the environment from spills that occur at service stations and vehicle accident sites, while also removing contaminated sediment in runoff that washes from roads and parking lots.

## 3. Key Operation Features

### 3.1. Scour Prevention

A key feature of the Stormceptor System is its patented scour prevention technology. This innovation ensures pollutants are captured and retained during all rainfall events, even extreme storms. The Stormceptor System provides continuous positive treatment for all rainfall events, including intense storms. Stormceptor slows incoming runoff, controlling and reducing velocities in the lower chamber to create a non-turbulent environment that promotes free oils and floatable debris to rise and sediment to settle.

The patented scour prevention technology, the fiberglass insert, regulates flows into the lower chamber through a combination of a weir and orifice while diverting high energy flows away through the upper chamber to prevent scouring. Laboratory testing demonstrated no scouring when tested up to 125% of the unit's operating rate, with the unit loaded to 100% sediment capacity (NJDEP, 2005). Second, the depth of the lower chamber ensures the sediment storage zone is adequately separated from the path of flow in the lower chamber to prevent scouring.

### 3.2. Operational Hydraulic Loading Rate

Designers and regulators need to evaluate the treatment capacity and performance of manufactured stormwater treatment systems. A commonly used parameter is the "operational hydraulic loading rate" which originated as a design methodology for wastewater treatment devices.

Operational hydraulic loading rate may be calculated by dividing the flow rate into a device by its settling area. This represents the critical settling velocity that is the prime determinant to quantify the influent particle size and density captured by the device. PCSWMM for Stormceptor uses a similar parameter that is calculated by dividing the hydraulic detention time in the device by the fall distance of the sediment.

$$v_{sc} = \frac{H}{\theta_H} = \frac{Q}{A_s}$$

Where:

$v_{sc}$  = critical settling velocity, ft/s (m/s)

H = tank depth, ft (m)

$\theta_H$  = hydraulic detention time, ft/s (m/s)

Q = volumetric flow rate, ft<sup>3</sup>/s (m<sup>3</sup>/s)

$A_s$  = surface area, ft<sup>2</sup> (m<sup>2</sup>)

(Tchobanoglous, G. and Schroeder, E.D. 1987. Water Quality. Addison Wesley.)

Unlike designing typical wastewater devices, stormwater systems are designed for highly variable flow rates including intense peak flows. PCSWMM for Stormceptor incorporates all of the flows into its calculations, ensuring that the operational hydraulic loading rate is considered not only for one flow rate, but for all flows including extreme events.

### 3.3. Double Wall Containment

The Stormceptor System was conceived as a pollution identifier to assist with identifying illicit discharges. The fiberglass insert has a continuous skirt that lines the concrete barrel wall for a depth of 18 inches (457 mm) that provides double wall containment for hydrocarbons storage. This protective barrier ensures that toxic floatables do not migrate through the concrete wall into the surrounding soils.

## 4. Stormceptor Product Line

### 4.1. Stormceptor Models

A summary of Stormceptor models and capacities are listed in Table 1.

**Table 1. Stormceptor Models**

| Stormceptor Model | Total Storage Volume<br>U.S. Gal (L) | Hydrocarbon Storage<br>Capacity U.S. Gal (L) | Maximum Sediment<br>Capacity ft <sup>3</sup> (L) |
|-------------------|--------------------------------------|--|--|
| STC 450i          | 470 (1,780)                          | 86 (330)                                     | 46 (1,302)                                       |
| STC 900           | 952 (3,600)                          | 251 (950)                                    | 89 (2,520)                                       |
| STC 1200          | 1,234 (4,670)                        | 251 (950)                                    | 127 (3,596)                                      |
| STC 1800          | 1,833 (6,940)                        | 251 (950)                                    | 207 (5,861)                                      |
| STC 2400          | 2,462 (9,320)                        | 840 (3,180)                                  | 205 (5,805)                                      |
| STC 3600          | 3,715 (1,406)                        | 840 (3,180)                                  | 373 (10,562)                                     |
| STC 4800          | 5,059 (1,950)                        | 909 (3,440)                                  | 543 (15,376)                                     |
| STC 6000          | 6,136 (23,230)                       | 909 (3,440)                                  | 687 (19,453)                                     |
| STC 7200          | 7,420 (28,090)                       | 1,059 (4,010)                                | 839 (23,757)                                     |
| STC 11000         | 11,194 (42,370)                      | 2,797 (10, 590)                              | 1,086 (30,752)                                   |
| STC 13000         | 13,348 (50,530)                      | 2,797 (10, 590)                              | 1,374 (38,907)                                   |
| STC 16000         | 15,918 (60,260)                      | 3,055 (11, 560)                              | 1,677 (47,487)                                   |

NOTE: Storage volumes may vary slightly from region to region. For detailed information, contact your local Stormceptor representative.

### 4.2. Inline Stormceptor

The Inline Stormceptor, Figure 1, is the standard design for most stormwater treatment applications. The patented Stormceptor design allows the Inline unit to maintain continuous positive treatment of total suspended solids (TSS) year-round, regardless of flow rate. The Inline Stormceptor is composed of a precast concrete tank with a fiberglass insert situated at the invert of the storm sewer pipe, creating an upper chamber above the insert and a lower chamber below the insert.

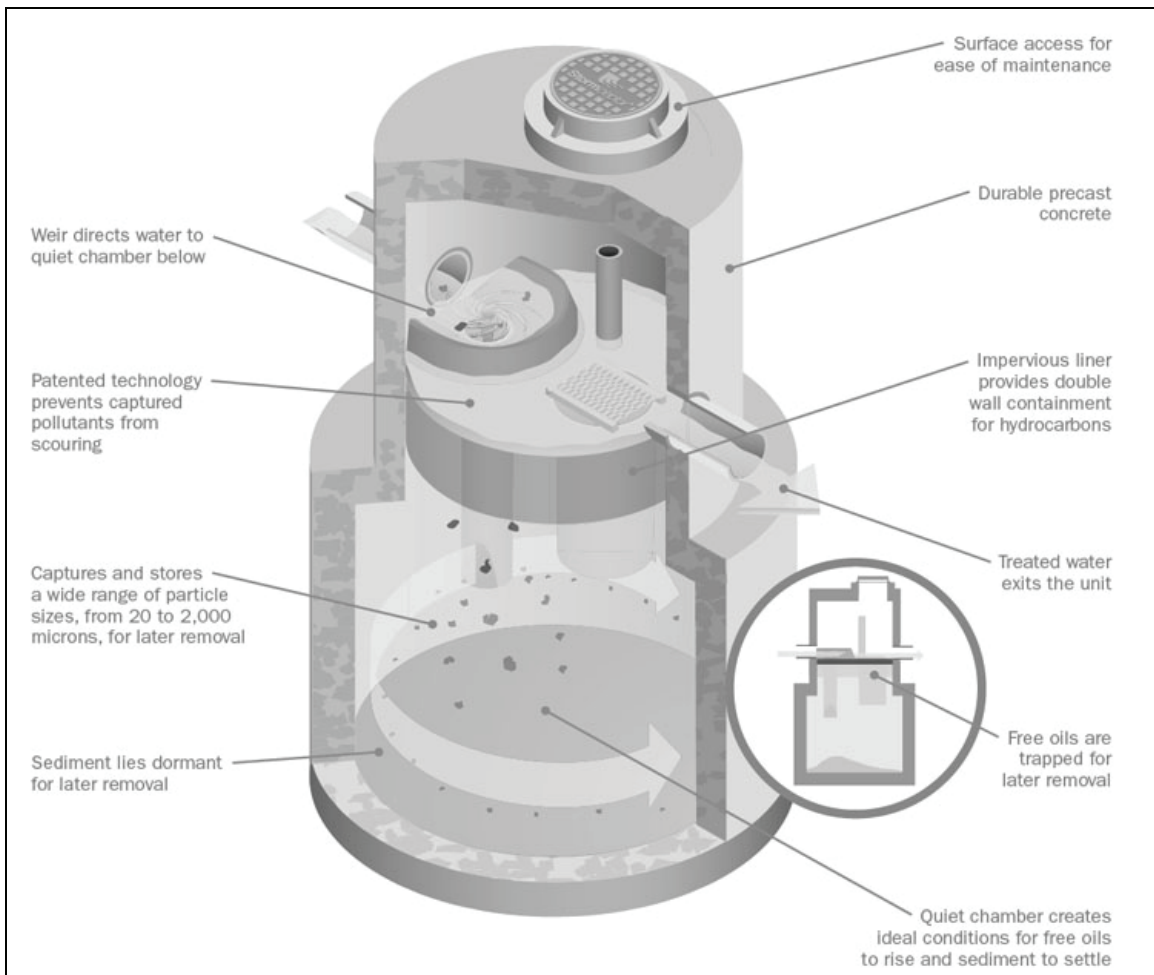

**Figure 1. Inline Stormceptor**

## Operation

As water flows into the Stormceptor unit, it is slowed and directed to the lower chamber by a weir and drop tee. The stormwater enters the lower chamber, a non-turbulent environment, allowing free oils to rise and sediment to settle. The oil is captured underneath the fiberglass insert and shielded from exposure to the concrete walls by a fiberglass skirt. After the pollutants separate, treated water continues up a riser pipe, and exits the lower chamber on the downstream side of the weir before leaving the unit. During high flow events, the Stormceptor System's patented scour prevention technology ensures continuous pollutant removal and prevents re-suspension of previously captured pollutants.

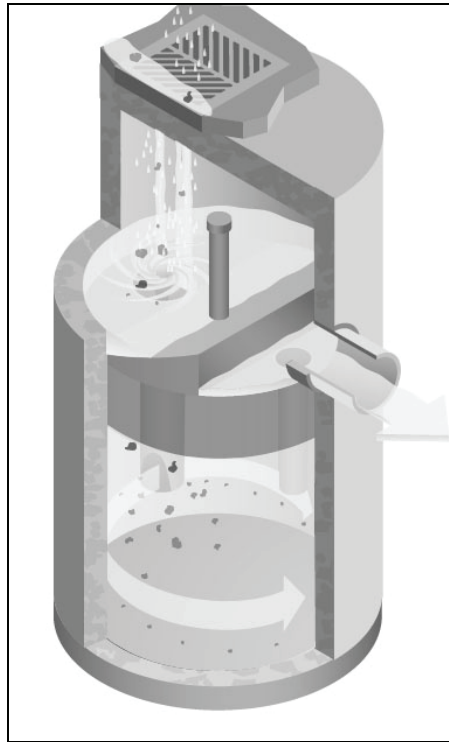

**Figure 2. Inlet Stormceptor**

#### **4.3. Inlet Stormceptor**

The Inlet Stormceptor System, Figure 2, was designed to provide protection for parking lots, loading bays, gas stations and other spill-prone areas. The Inlet Stormceptor is designed to remove sediment from stormwater introduced through a grated inlet, a storm sewer pipe, or both.

The Inlet Stormceptor design operates in the same manner as the Inline unit, providing continuous positive treatment, and ensuring that captured material is not re-suspended.

#### **4.4. Series Stormceptor**

Designed to treat larger drainage areas, the Series Stormceptor System, Figure 3, consists of two adjacent Stormceptor models that function in parallel. This design eliminates the need for additional structures and piping to reduce installation costs.

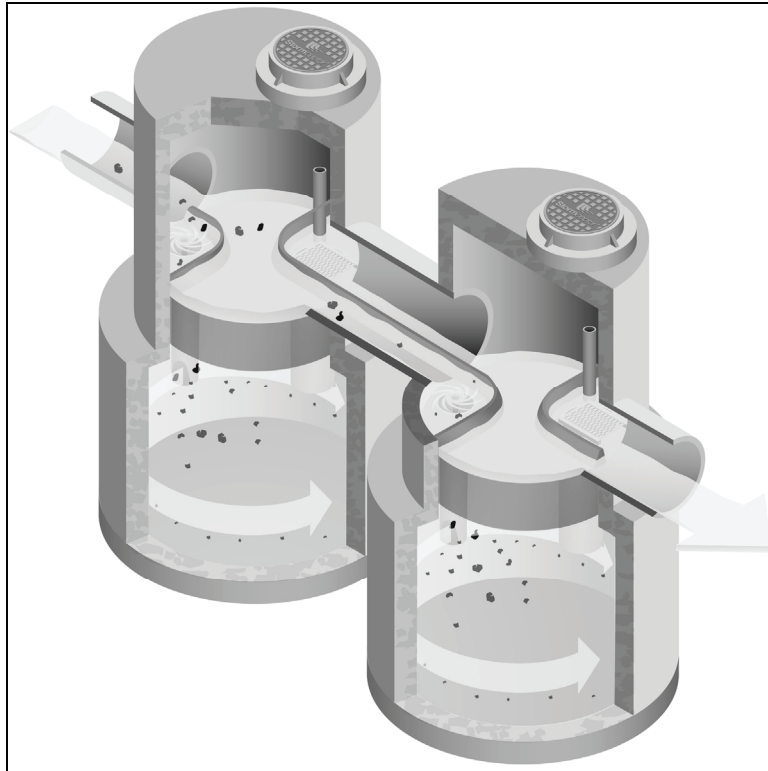

**Figure 3. Series System**

The Series Stormceptor design operates in the same manner as the Inline unit, providing continuous positive treatment, and ensuring that captured material is not re-suspended.

## 5. Sizing the Stormceptor System

The Stormceptor System is a versatile product that can be used for many different aspects of water quality improvement. While addressing these needs, there are conditions that the designer needs to be aware of in order to size the Stormceptor model to meet the demands of each individual site in an efficient and cost-effective manner.

PCSWMM for Stormceptor is the support tool used for identifying the appropriate Stormceptor model. In order to size a unit, it is recommended the user follow the seven design steps in the program. The steps are as follows:

### STEP 1 – Project Details

The first step prior to sizing the Stormceptor System is to clearly identify the water quality objective for the development. It is recommended that a level of annual sediment (TSS) removal be identified and defined by a particle size distribution.

### STEP 2 – Site Details

Identify the site development by the drainage area and the level of imperviousness. It is recommended that imperviousness be calculated based on the actual area of imperviousness based on paved surfaces, sidewalks and rooftops.

### STEP 3 – Upstream Attenuation

The Stormceptor System is designed as a water quality device and is sometimes used in conjunction with onsite water quantity control devices such as ponds or underground detention systems. When possible, a greater benefit is typically achieved when installing a Stormceptor unit upstream of a detention facility. By placing the Stormceptor unit upstream of a detention structure, a benefit of less maintenance of the detention facility is realized.

## STEP 4 – Particle Size Distribution

It is critical that the PSD be defined as part of the water quality objective. PSD is critical for the design of treatment system for a unit process of gravity settling and governs the size of a treatment system. A range of particle sizes has been provided and it is recommended that clays and silt-sized particles be considered in addition to sand and gravel-sized particles. Options and sample PSDs are provided in PCSWMM for Stormceptor. The default particle size distribution is the Fine Distribution, Table 2, option.

**Table 2. Fine Distribution**

| Particle Size | Distribution | Specific Gravity |
|---------------|--------------|------------------|
| 20            | 20%          | 1.3              |
| 60            | 20%          | 1.8              |
| 150           | 20%          | 2.2              |
| 400           | 20%          | 2.65             |
| 2000          | 20%          | 2.65             |

If the objective is the long-term removal of 80% of the total suspended solids on a given site, the PSD should be representative of the expected sediment on the site. For example, a system designed to remove 80% of coarse particles (greater than 75 microns) would provide relatively poor removal efficiency of finer particles that may be naturally prevalent in runoff from the site.

Since the small particle fraction contributes a disproportionately large amount of the total available particle surface area for pollutant adsorption, a system designed primarily for coarse particle capture will compromise water quality objectives.

## STEP 5 – Rainfall Records

Local historical rainfall has been acquired from the U.S. National Oceanic and Atmospheric Administration, Environment Canada and regulatory agencies across North America. The rainfall data provided with PCSMM for Stormceptor provides an accurate estimation of small storm hydrology by modeling actual historical storm events including duration, intensities and peaks.

## STEP 6 – Summary

At this point, the program may be executed to predict the level of TSS removal from the site. Once the simulation has completed, a table shall be generated identifying the TSS removal of each Stormceptor unit.

## STEP 7 – Sizing Summary

Performance estimates of all Stormceptor units for the given site parameters will be displayed in a tabular format. The unit that meets the water quality objective, identified in Step 1, will be highlighted.

## 5.1. PCSWMM for Stormceptor

The Stormceptor System has been developed in conjunction with PCSWMM for Stormceptor as a technological solution to achieve water quality goals. Together, these two innovations model, simulate, predict and calculate the water quality objectives desired by a design engineer for TSS removal.

PCSWMM for Stormceptor is a proprietary sizing program which uses site specific inputs to a computer model to simulate sediment accumulation, hydrology and long-term total suspended solids removal. The model has been calibrated to field monitoring results from Stormceptor units that have been monitored in North America. The sizing methodology can be described by three processes:

1. Determination of real time hydrology
2. Buildup and wash off of TSS from impervious land areas
3. TSS transport through the Stormceptor (settling and discharge). The use of a calibrated model is the preferred method for sizing stormwater quality structures for the following reasons:
  - » The hydrology of the local area is properly and accurately incorporated in the sizing (distribution of flows, flow rate ranges and peaks, back-to-back storms, inter-event times)
  - » The distribution of TSS with the hydrology is properly and accurately considered in the sizing
  - » Particle size distribution is properly considered in the sizing
  - » The sizing can be optimized for TSS removal
  - » The cost benefit of alternate TSS removal criteria can be easily assessed
  - » The program assesses the performance of all Stormceptor models. Sizing may be selected based on a specific water quality outcome or based on the Maximum Extent Practicable

For more information regarding PCSWMM for Stormceptor, contact your local Stormceptor representative, or visit [www.imbriumsystems.com](http://www.imbriumsystems.com) to download a free copy of the program.

## 5.2. Sediment Loading Characteristics

The way in which sediment is transferred to stormwater can have a considerable effect on which type of system is implemented. On typical impervious surfaces (e.g. parking lots) sediment will build over time and wash off with the next rainfall. When rainfall patterns are examined, a short intense storm will have a higher concentration of sediment than a long slow drizzle. Together with rainfall data representing the site's typical rainfall patterns, sediment loading characteristics play a part in the correct sizing of a stormwater quality device.

### Typical Sites

For standard site design of the Stormceptor System, PCSWMM for Stormceptor is utilized to accurately assess the unit's performance. As an integral part of the product's design, the program can be used to meet local requirements for total suspended solid removal. Typical installations of manufactured stormwater treatment devices would occur on areas such as paved parking lots or paved roads. These are considered "stable" surfaces which have non – erodible surfaces.

### Unstable Sites

While standard sites consist of stable concrete or asphalt surfaces, sites such as gravel parking lots, or maintenance yards with stockpiles of sediment would be classified as "unstable". These types of sites do not exhibit first flush characteristics, are highly erodible and exhibit atypical sediment loading characteristics and must therefore be sized more carefully. Contact your local Stormceptor representative for assistance in selecting a proper unit sized for such unstable sites.

## 6. Spill Controls

When considering the removal of total petroleum hydrocarbons (TPH) from a storm sewer system there are two functions of the system: oil removal, and spill capture.

'Oil Removal' describes the capture of the minute volumes of free oil mobilized from impervious surfaces. In this instance relatively low concentrations, volumes and flow rates are considered. While the Stormceptor unit will still provide an appreciable oil removal function during higher flow events and/or with higher TPH concentrations, desired effluent limits may be exceeded under these conditions.

'Spill Capture' describes a manner of TPH removal more appropriate to recovery of a relatively high volume of a single phase deleterious liquid that is introduced to the storm sewer system over a relatively short duration. The two design criteria involved when considering this manner of introduction are overall volume and the specific gravity of the material. A standard Stormceptor unit will be able to capture and retain a maximum spill volume and a minimum specific gravity.

For spill characteristics that fall outside these limits, unit modifications are required. Contact your local Stormceptor Representative for more information.

One of the key features of the Stormceptor technology is its ability to capture and retain spills. While the standard Stormceptor System provides excellent protection for spill control, there are additional options to enhance spill protection if desired.

### 6.1. Oil Level Alarm

The oil level alarm is an electronic monitoring system designed to trigger a visual and audible alarm when a pre-set level of oil is reached within the lower chamber. As a standard, the oil

level alarm is designed to trigger at approximately 85% of the unit's available depth level for oil capture. The feature acts as a safeguard against spills caused by exceeding the oil storage capacity of the separator and eliminates the need for manual oil level inspection.

The oil level alarm installed on the Stormceptor insert is illustrated in Figure 4.

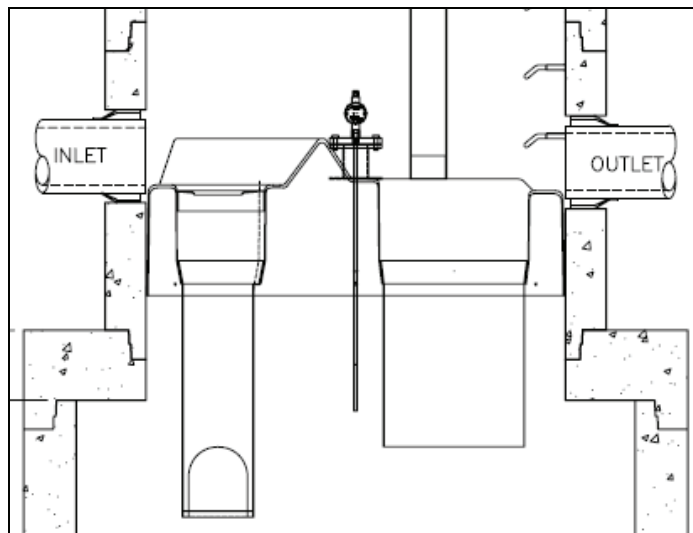

Figure 4. Oil level alarm

### 6.2. Increased Volume Storage Capacity

The Stormceptor unit may be modified to store a greater spill volume than is typically available. Under such a scenario, instead of installing a larger than required unit, modifications can be made to the recommended Stormceptor model to accommodate larger volumes. Contact your local Stormceptor representative for additional information and assistance for modifications.

## 7. Stormceptor Options

The Stormceptor System allows flexibility to incorporate to existing and new storm drainage infrastructure. The following section identifies considerations that should be reviewed when installing the system into a drainage network. For conditions that fall outside of the recommendations in this section, please contact your local Stormceptor representative for further guidance.

### 7.1. Installation Depth Minimum Cover

The minimum distance from the top of grade to the crown of the inlet pipe is 24 inches (600 mm). For situations that have a lower minimum distance, contact your local Stormceptor representative.

### 7.2. Maximum Inlet and Outlet Pipe Diameters

Maximum inlet and outlet pipe diameters are illustrated in Figure 5. Contact your local Stormceptor representative for larger pipe diameters

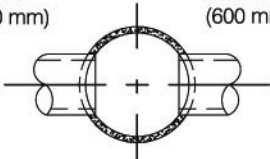
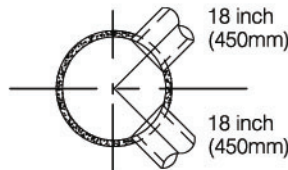
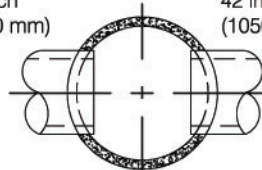
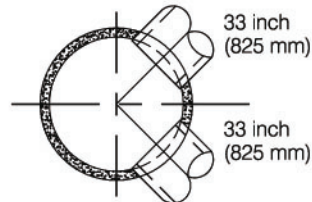
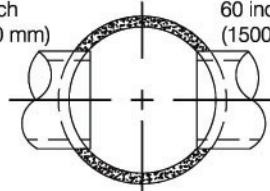
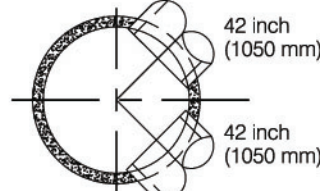
| Upper Chamber Diameter                   | Maximum Pipe Diameters for Straight Through and 90° Bends (Based on Concrete Pipe)                                      |   |
|--|---|---|
| Inlet Stormceptor                        | 24 inch (600 mm)  24 inch (600 mm)     |  18 inch (450mm)<br>18 inch (450mm)       |
| Inline Stormceptor                       | 42 inch (1050 mm)  42 inch (1050 mm)  |  33 inch (825 mm)<br>33 inch (825 mm)    |
| Inline Stormceptor or Series Stormceptor | 60 inch (1500 mm)  60 inch (1500 mm) |  42 inch (1050 mm)<br>42 inch (1050 mm) |

**Figure 5. Maximum pipe diameters for straight through and bend applications**

\*The bend should only be incorporated into the second structure (downstream structure) of the Series Stormceptor System

### 7.3. Bends

The Stormceptor System can be used to change horizontal alignment in the storm drain network up to a maximum of 90 degrees. Figure 6 illustrates the typical bend situations of the Stormceptor System. Bends should only be applied to the second structure (downstream structure) of the Series Stormceptor System.

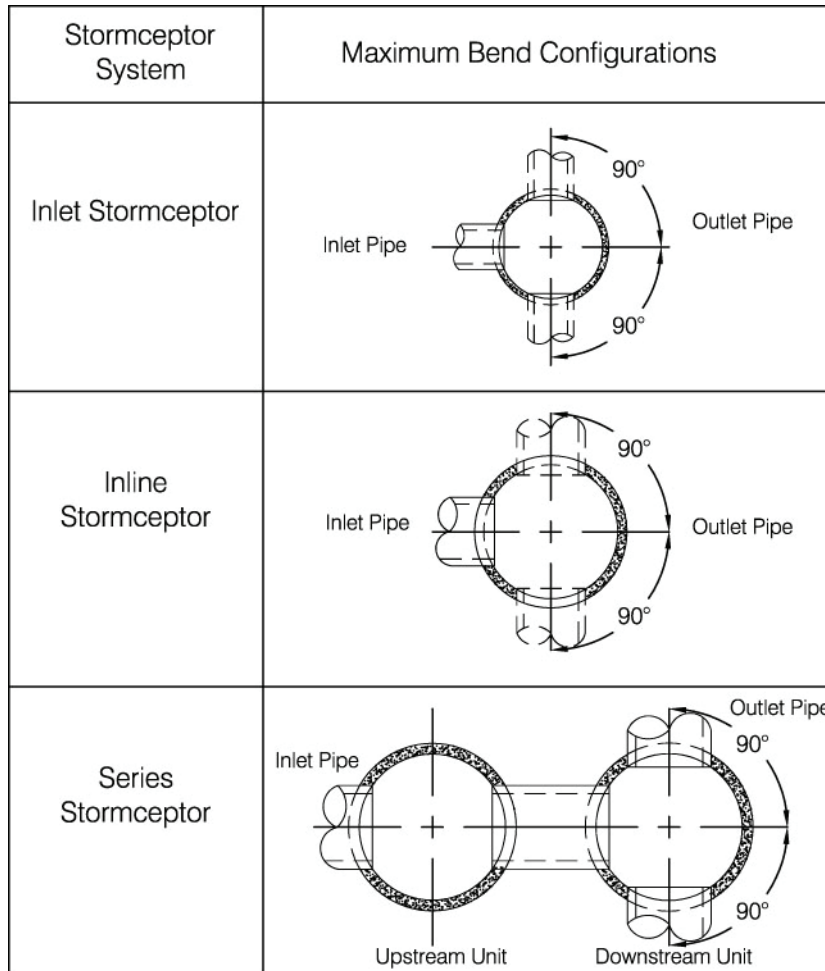

**Figure 6. Maximum bend angles**

#### 7.4. Multiple Inlet Pipes

The Inlet and Inline Stormceptor System can accommodate two or more inlet pipes. The maximum number of inlet pipes that can be accommodated into a Stormceptor unit is a function of the number, alignment and diameter of the pipes and its effects on the structural integrity of the precast concrete. When multiple inlet pipes are used for new developments, each inlet pipe shall have an invert elevation 3 inches (75 mm) higher than the outlet pipe invert elevation.

#### 7.5. Inlet/Outlet Pipe Invert Elevations

Recommended inlet and outlet pipe invert differences are listed in Table 3.

**Table 3. Recommended Drops Between Inlet and Outlet Pipe Inverts**

| Number of Inlet Pipes | Inlet System     | In-Line System   | Series System    |
|-----------------------|------------------|------------------|------------------|
| 1                     | 3 inches (75 mm) | 1 inch (25 mm)   | 3 inches (75 mm) |
| >1                    | 3 inches (75 mm) | 3 inches (75 mm) | Not Applicable   |

#### 7.6. Shallow Stormceptor

In cases where there may be restrictions to the depth of burial of storm sewer systems. In this situation, for selected Stormceptor models, the lower chamber components may be increased in diameter to reduce the overall depth of excavation required.

#### 7.7. Customized Live Load

The Stormceptor system is typically designed for local highway truck loading (AASHTO HS- 20). When the project requires live loads greater than HS-20, the Stormceptor System may be customized structurally for a pre-specified live load. Contact your local Stormceptor representative for customized loading conditions.

## 7.8. Pre-treatment

The Stormceptor System may be sized to remove sediment and for spills control in conjunction with other stormwater BMPs to meet the water quality objective. For pretreatment applications, the Stormceptor System should be the first unit in a treatment train. The benefits of pre-treatment include the extension of the operational life (extension of maintenance frequency) of large stormwater management facilities, prevention of spills and lower total life-cycle maintenance cost.

## 7.9. Head loss

The head loss through the Stormceptor System is similar to a 60 degree bend at a manhole. The K value for calculating minor losses is approximately 1.3 (minor loss =  $k \cdot 1.3v^2/2g$ ).

However, when a Submerged modification is applied to a Stormceptor unit, the corresponding K value is 4.

## 7.10. Submerged

The Submerged modification, Figure 7, allows the Stormceptor System to operate in submerged or partially submerged storm sewers. This configuration can be installed on all models of the Stormceptor System by modifying the fiberglass insert. A customized weir height and a secondary drop tee are added.

Submerged instances are defined as standing water in the storm drain system during zero flow conditions. In these instances, the following information is necessary for the proper design and application of submerged modifications:

- Stormceptor top of grade elevation
- Stormceptor outlet pipe invert elevation
- Standing water elevation

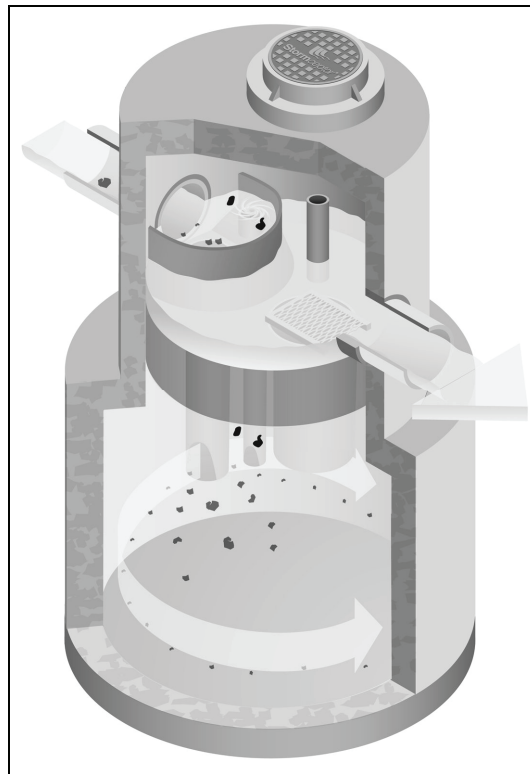

**Figure 7. Submerged Stormceptor**

## 8. Comparing Technologies

Designers have many choices available to achieve water quality goals in the treatment of stormwater runoff. Since many alternatives are available for use in stormwater quality treatment it is important to consider how to make an appropriate comparison between “approved alternatives”. The following is a guide to assist with the accurate comparison of differing technologies and performance claims.

### 8.1. Particle Size Distribution (PSD)

The most sensitive parameter to the design of a stormwater quality device is the selection of the design particle size. While it is recommended that the actual particle size distribution (PSD) for sites be measured prior to sizing, alternative values for particle size should be selected to represent what is likely to occur naturally on the site. A reasonable estimate of a particle size distribution likely to be found on parking lots or other impervious surfaces should consist of a wide range of particles such as 20 microns to 2,000 microns (Ontario MOE, 1994).

There is no absolute right particle size distribution or specific gravity and the user is cautioned to review the site location, characteristics, material handling practices and regulatory requirements when selecting a particle size distribution. When comparing technologies, designs using different PSDs will result in incomparable TSS removal efficiencies. The PSD of the TSS removed needs to be standard between two products to allow for an accurate comparison.

### 8.2. Scour Prevention

In order to accurately predict the performance of a manufactured treatment device, there must be confidence that it will perform under all conditions. Since rainfall patterns cannot be predicted, stormwater quality devices placed in storm sewer systems must be able to withstand extreme events, and ensure that all pollutants previously captured are retained in the system.

In order to have confidence in a system’s performance under extreme conditions, independent validation of scour prevention is essential when examining different technologies. Lack of independent verification of scour prevention should make a designer wary of accepting any product’s performance claims.

### 8.3. Hydraulics

Full scale laboratory testing has been used to confirm the hydraulics of the Stormceptor System. Results of lab testing have been used to physically design the Stormceptor System and the sewer pipes entering and leaving the unit. Key benefits of Stormceptor are:

- Low head loss (typical k value of 1.3)
- Minimal inlet/outlet invert elevation drop across the structure
- Use as a bend structure
- Accommodates multiple inlets

The adaptability of the treatment device to the storm sewer design infrastructure can affect the overall performance and cost of the site.

### 8.4. Hydrology

Stormwater quality treatment technologies need to perform under varying climatic conditions. These can vary from long low intensity rainfall to short duration, high intensity storms. Since a treatment device is expected to perform under all these conditions, it makes sense that any system’s design should accommodate those conditions as well.

Long-term continuous simulation evaluates the performance of a technology under the varying conditions expected in the climate of the subject site. Single, peak event design does not provide this information and is not equivalent to long-term simulation. Designers should request long-term simulation performance to ensure the technology can meet the long-term water quality objective.

## 9. Testing

The Stormceptor System has been the most widely monitored stormwater treatment technology in the world. Performance verification and monitoring programs are completed to the strictest standards and integrity. Since its introduction in 1990, numerous independent field tests and studies detailing the effectiveness of the Stormceptor System have been completed.

- Coventry University, UK – 97% removal of oil, 83% removal of sand and 73% removal of peat
- National Water Research Institute, Canada, - scaled testing for the development of the Stormceptor System identifying both TSS removal and scour prevention.
- New Jersey TARP Program – full scale testing of an STC 900 demonstrating 75% TSS removal of particles from 1 to 1000 microns. Scour testing completed demonstrated that the system does not scour. The New Jersey Department of Environmental Protection was followed.
- City of Indianapolis – full scale testing of an STC 900 demonstrating over 80% TSS removal of particles from 50 microns to 300 microns at 130% of the unit's operating rate. Scour testing completed demonstrated that the system does not scour.
- Westwood Massachusetts (1997), demonstrated >80% TSS removal
- Como Park (1997), demonstrated 76% TSS removal
- Ontario MOE SWAMP Program – 57% removal of 1 to 25 micron particles
- Laval Quebec – 50% removal of 1 to 25 micron particles

## 10. Installation

The installation of the concrete Stormceptor should conform in general to state highway, or local specifications for the installation of manholes. Selected sections of a general specification that are applicable are summarized in the following sections.

### 10.1. Excavation

Excavation for the installation of the Stormceptor should conform to state highway, or local specifications. Topsoil removed during the excavation for the Stormceptor should be stockpiled in designated areas and should not be mixed with subsoil or other materials.

Topsoil stockpiles and the general site preparation for the installation of the Stormceptor should conform to state highway or local specifications.

The Stormceptor should not be installed on frozen ground. Excavation should extend a minimum of 12 inches (300 mm) from the precast concrete surfaces plus an allowance for shoring and bracing where required. If the bottom of the excavation provides an unsuitable foundation additional excavation may be required.

In areas with a high water table, continuous dewatering may be required to ensure that the excavation is stable and free of water.

### 10.2. Backfilling

Backfill material should conform to state highway or local specifications. Backfill material should be placed in uniform layers not exceeding 12 inches (300mm) in depth and compacted to state highway or local specifications.

## 11. Stormceptor Construction Sequence

The concrete Stormceptor is installed in sections in the following sequence:

1. Aggregate base
2. Base slab
3. Lower chamber sections
4. Upper chamber section with fiberglass insert
5. Connect inlet and outlet pipes
6. Assembly of fiberglass insert components (drop tee, riser pipe, oil cleanout port and orifice plate)
7. Remainder of upper chamber
8. Frame and access cover

The precast base should be placed level at the specified grade. The entire base should be in contact with the underlying compacted granular material. Subsequent sections, complete with joint seals, should be installed in accordance with the precast concrete manufacturer's recommendations.

Adjustment of the Stormceptor can be performed by lifting the upper sections free of the excavated area, re-leveling the base and re-installing the sections. Damaged sections and gaskets should be repaired or replaced as necessary. Once the Stormceptor has been constructed, any lift holes must be plugged with mortar.

## 12. Maintenance

### 12.1. Health and Safety

The Stormceptor System has been designed considering safety first. It is recommended that confined space entry protocols be followed if entry to the unit is required. In addition, the fiberglass insert has the following health and safety features:

- Designed to withstand the weight of personnel
- A safety grate is located over the 24 inch (600 mm) riser pipe opening
- Ladder rungs can be provided for entry into the unit, if required

### 12.2. Maintenance Procedures

Maintenance of the Stormceptor system is performed using vacuum trucks. No entry into the unit is required for maintenance (in most cases). The vacuum service industry is a well-established sector of the service industry that cleans underground tanks, sewers and catch basins. Costs to clean a Stormceptor will vary based on the size of unit and transportation distances.

The need for maintenance can be determined easily by inspecting the unit from the surface. The depth of oil in the unit can be determined by inserting a dipstick in the oil inspection/cleanout port.

Similarly, the depth of sediment can be measured from the surface without entry into the Stormceptor via a dipstick tube equipped with a ball valve. This tube would be inserted through the riser pipe. Maintenance should be performed once the sediment depth exceeds the guideline values provided in the Table 4.

**Table 4. Sediment Depths Indicating Required Servicing\***

| Particle Size  | Specific Gravity           |
|--|----------------------------|
| Model  | Sediment Depth inches (mm) |
| 450i   | 8 (200)                    |
| 900  | 8 (200)                    |
| 1200   | 10 (250)                   |
| 1800   | 15 (381)                   |
| 2400   | 12 (300)                   |
| 3600   | 17 (430)                   |
| 4800   | 15 (380)                   |
| 6000   | 18 (460)                   |
| 7200   | 15 (381)                   |
| 11000  | 17 (380)                   |
| 13000  | 20 (500)                   |
| 16000  | 17 (380)                   |
| * based on 15% of the Stormceptor unit's total storage |                            |

Although annual servicing is recommended, the frequency of maintenance may need to be increased or reduced based on local conditions (i.e. if the unit is filling up with sediment more quickly than projected, maintenance may be required semi-annually; conversely once the site has stabilized maintenance may only be required every two or three years).

Oil is removed through the oil inspection/cleanout port and sediment is removed through the riser pipe. Alternatively oil could be removed from the 24 inches (600 mm) opening if water is removed from the lower chamber to lower the oil level below the drop pipes.

The following procedures should be taken when cleaning out Stormceptor:

1. Check for oil through the oil cleanout port
2. Remove any oil separately using a small portable pump
3. Decant the water from the unit to the sanitary sewer, if permitted by the local regulating authority, or into a separate containment tank
4. Remove the sludge from the bottom of the unit using the vacuum truck
5. Re-fill Stormceptor with water where required by the local jurisdiction

### 12.3. Submerged Stormceptor

Careful attention should be paid to maintenance of the Submerged Stormceptor System. In cases where the storm drain system is submerged, there is a requirement to plug both the inlet and outlet pipes to economically clean out the unit.

### 12.4. Hydrocarbon Spills

The Stormceptor is often installed in areas where the potential for spills is great. The Stormceptor System should be cleaned immediately after a spill occurs by a licensed liquid waste hauler.

### 12.5. Disposal

Requirements for the disposal of material from the Stormceptor System are similar to that of any other stormwater Best Management Practice (BMP) where permitted. Disposal options for the sediment may range from disposal in a sanitary trunk sewer upstream of a sewage treatment plant, to disposal in a sanitary landfill site. Petroleum waste products collected in the Stormceptor (free oil/chemical/fuel spills) should be removed by a licensed waste management company.

### 12.6. Oil Sheens

With a steady influx of water with high concentrations of oil, a sheen may be noticeable at the Stormceptor outlet. This may occur because a rainbow or sheen can be seen at very small oil concentrations (<10 mg/L). Stormceptor will remove over 98% of all free oil spills from storm sewer systems for dry weather or frequently occurring runoff events.

The appearance of a sheen at the outlet with high influent oil concentrations does not mean the unit is not working to this level of removal. In addition, if the influent oil is emulsified the Stormceptor will not be able to remove it. The Stormceptor is designed for free oil removal and not emulsified conditions.



## SUPPORT

Drawings and specifications are available at [www.ContechES.com](http://www.ContechES.com).

Site-specific design support is available from our engineers.

©2020 Contech Engineered Solutions LLC, a QUIKRETE Company

Contech Engineered Solutions LLC provides site solutions for the civil engineering industry. Contech's portfolio includes bridges, drainage, sanitary sewer, stormwater, and earth stabilization products. For information, visit [www.ContechES.com](http://www.ContechES.com) or call 800.338.1122

NOTHING IN THIS CATALOG SHOULD BE CONSTRUED AS A WARRANTY. APPLICATIONS SUGGESTED HEREIN ARE DESCRIBED ONLY TO HELP READERS MAKE THEIR OWN EVALUATIONS AND DECISIONS, AND ARE NEITHER GUARANTEES NOR WARRANTIES OF SUITABILITY FOR ANY APPLICATION. CONTECH MAKES NO WARRANTY WHATSOEVER, EXPRESS OR IMPLIED, RELATED TO THE APPLICATIONS, MATERIALS, COATINGS, OR PRODUCTS DISCUSSED HEREIN. ALL IMPLIED WARRANTIES OF MERCHANTABILITY AND ALL IMPLIED WARRANTIES OF FITNESS FOR ANY PARTICULAR PURPOSE ARE DISCLAIMED BY CONTECH. SEE CONTECH'S CONDITIONS OF SALE (AVAILABLE AT [WWW.CONTECHES.COM/COS](http://WWW.CONTECHES.COM/COS)) FOR MORE INFORMATION.

## CDS<sup>®</sup> Inspection and Maintenance Guide

---



## Maintenance

The CDS system should be inspected at regular intervals and maintained when necessary to ensure optimum performance. The rate at which the system collects pollutants will depend more heavily on site activities than the size of the unit. For example, unstable soils or heavy winter sanding will cause the grit chamber to fill more quickly but regular sweeping of paved surfaces will slow accumulation.

## Inspection

Inspection is the key to effective maintenance and is easily performed. Pollutant transport and deposition may vary from year to year and regular inspections will help ensure that the system is cleaned out at the appropriate time. At a minimum, inspections should be performed twice per year (e.g. spring and fall) however more frequent inspections may be necessary in climates where winter sanding operations may lead to rapid accumulations, or in equipment washdown areas. Installations should also be inspected more frequently where excessive amounts of trash are expected.

The visual inspection should ascertain that the system components are in working order and that there are no blockages or obstructions in the inlet and separation screen. The inspection should also quantify the accumulation of hydrocarbons, trash, and sediment in the system. Measuring pollutant accumulation can be done with a calibrated dipstick, tape measure or other measuring instrument. If absorbent material is used for enhanced removal of hydrocarbons, the level of discoloration of the sorbent material should also be identified during inspection. It is useful and often required as part of an operating permit to keep a record of each inspection. A simple form for doing so is provided.

Access to the CDS unit is typically achieved through two manhole access covers. One opening allows for inspection and cleanout of the separation chamber (cylinder and screen) and isolated sump. The other allows for inspection and cleanout of sediment captured and retained outside the screen. For deep units, a single manhole access point would allow both sump cleanout and access outside the screen.

The CDS system should be cleaned when the level of sediment has reached 75% of capacity in the isolated sump or when an appreciable level of hydrocarbons and trash has accumulated. If absorbent material is used, it should be replaced when significant discoloration has occurred. Performance will not be impacted until 100% of the sump capacity is exceeded however it is recommended that the system be cleaned prior to that for easier removal of sediment. The level of sediment is easily determined by measuring from finished grade down to the top of the sediment pile. To avoid underestimating the level of sediment in the chamber, the measuring device must be lowered to the top of the sediment pile carefully. Particles at the top of the pile typically offer less resistance to the end of the rod than consolidated particles toward the bottom of the pile. Once this measurement is recorded, it should be compared to the as-built drawing for the unit to determine whether the height of the sediment pile off the bottom of the sump floor exceeds 75% of the total height of isolated sump.

## Cleaning

Cleaning of a CDS system should be done during dry weather conditions when no flow is entering the system. The use of a vacuum truck is generally the most effective and convenient method of removing pollutants from the system. Simply remove the manhole covers and insert the vacuum hose into the sump. The system should be completely drained down and the sump fully evacuated of sediment. The area outside the screen should also be cleaned out if pollutant build-up exists in this area.

In installations where the risk of petroleum spills is small, liquid contaminants may not accumulate as quickly as sediment. However, the system should be cleaned out immediately in the event of an oil or gasoline spill should be cleaned out immediately. Motor oil and other hydrocarbons that accumulate on a more routine basis should be removed when an appreciable layer has been captured. To remove these pollutants, it may be preferable to use absorbent pads since they are usually less expensive to dispose than the oil/water emulsion that may be created by vacuuming the oily layer. Trash and debris can be netted out to separate it from the other pollutants. The screen should be power washed to ensure it is free of trash and debris.

Manhole covers should be securely seated following cleaning activities to prevent leakage of runoff into the system from above and also to ensure that proper safety precautions have been followed. Confined space entry procedures need to be followed if physical access is required. Disposal of all material removed from the CDS system should be done in accordance with local regulations. In many jurisdictions, disposal of the sediments may be handled in the same manner as the disposal of sediments removed from catch basins or deep sump manholes.



| CDS Model | Diameter |     | Distance from Water Surface to Top of Sediment Pile |     | Sediment Storage Capacity |                |
|-----------|----------|-----|---|-----|---------------------------|----------------|
|           | ft       | m   | ft  | m   | y <sup>3</sup>            | m <sup>3</sup> |
| CDS1515   | 3        | 0.9 | 3.0   | 0.9 | 0.5                       | 0.4            |
| CDS2015   | 4        | 1.2 | 3.0   | 0.9 | 0.9                       | 0.7            |
| CDS2015   | 5        | 1.3 | 3.0   | 0.9 | 1.3                       | 1.0            |
| CDS2020   | 5        | 1.3 | 3.5   | 1.1 | 1.3                       | 1.0            |
| CDS2025   | 5        | 1.3 | 4.0   | 1.2 | 1.3                       | 1.0            |
| CDS3020   | 6        | 1.8 | 4.0   | 1.2 | 2.1                       | 1.6            |
| CDS3025   | 6        | 1.8 | 4.0   | 1.2 | 2.1                       | 1.6            |
| CDS3030   | 6        | 1.8 | 4.6   | 1.4 | 2.1                       | 1.6            |
| CDS3035   | 6        | 1.8 | 5.0   | 1.5 | 2.1                       | 1.6            |
| CDS4030   | 8        | 2.4 | 4.6   | 1.4 | 5.6                       | 4.3            |
| CDS4040   | 8        | 2.4 | 5.7   | 1.7 | 5.6                       | 4.3            |
| CDS4045   | 8        | 2.4 | 6.2   | 1.9 | 5.6                       | 4.3            |
| CDS5640   | 10       | 3.0 | 6.3   | 1.9 | 8.7                       | 6.7            |
| CDS5653   | 10       | 3.0 | 7.7   | 2.3 | 8.7                       | 6.7            |
| CDS5668   | 10       | 3.0 | 9.3   | 2.8 | 8.7                       | 6.7            |
| CDS5678   | 10       | 3.0 | 10.3  | 3.1 | 8.7                       | 6.7            |

Table 1: CDS Maintenance Indicators and Sediment Storage Capacities



**Support**

- Drawings and specifications are available at [www.contechstormwater.com](http://www.contechstormwater.com).
- Site-specific design support is available from our engineers.

©2017 Contech Engineered Solutions LLC, a QUIKRETE Company

Contech Engineered Solutions LLC provides site solutions for the civil engineering industry. Contech's portfolio includes bridges, drainage, sanitary sewer, stormwater, earth stabilization and wastewater treatment products. For information, visit [www.ContechES.com](http://www.ContechES.com) or call 800.338.1122

NOTHING IN THIS CATALOG SHOULD BE CONSTRUED AS AN EXPRESSED WARRANTY OR AN IMPLIED WARRANTY OF MERCHANTABILITY OR FITNESS FOR ANY PARTICULAR PURPOSE. SEE THE CONTECH STANDARD CONDITION OF SALES (VIEWABLE AT [WWW.CONTECHES.COM/COS](http://WWW.CONTECHES.COM/COS)) FOR MORE INFORMATION.

The product(s) described may be protected by one or more of the following US patents: 5,322,629; 5,624,576; 5,707,527; 5,759,415; 5,788,848; 5,985,157; 6,027,639; 6,350,374; 6,406,218; 6,641,720; 6,511,595; 6,649,048; 6,991,114; 6,998,038; 7,186,058; 7,296,692; 7,297,266; 7,517,450 related foreign patents or other patents pending.

