



Concord Select Board Meeting
AGENDA ACTION REQUEST

Monday, September 23, 2024

1

Call to Order

Requested by: SB Chair

Action Sought: Open Meeting

Proposed Motion(s)

None Anticipated

Additional Information

Open Public Comment

Board Action

<i>Motion</i>	<i>Second</i>	<i>In favor</i>	<i>Opposed</i>	<i>Disposition</i>



TOWN OF CONCORD

TOWN HOUSE - P.O. BOX 535
 CONCORD, MASSACHUSETTS 01742

Select Board Agenda

Monday, September 23, 2024 at 6:00 PM
 Town House, Select Board Room, 22 Monument Square

Join Zoom Meeting

<https://us02web.zoom.us/j/89493040608?pwd=FC0Fy9btnV08DlibWIwn21ewkGB9Qb.1>

Meeting ID: 894 9304 0608
 Passcode: 277393
 Dial In Toll-Free: 833 548 0276

#	Time*	Agenda Item
I.	6:00 PM	Public Comment: Public Comment is limited to up to 15 minutes, with no more than 3 minutes allocated to any one speaker. Public Comment is limited to items that are not on the agenda.
II.	6:15 PM	Consent Agenda <ul style="list-style-type: none"> a. Meeting Minutes: August 19, 2024 b. Town Accountant Warrants: September 6, 2024; September 19, 2024 c. Gift Acceptance: Fidelity Charitable Donor Fund Grant for the Concord Council on Aging Gift Account on behalf of the Leigh Family Gift Fund in the amount of \$1,000. d. Select Board Appointments: <ul style="list-style-type: none"> i. Chris LaFrance, of 805 Barrett's Mill Rd., to the Economic Vitality Committee for a term to expire May 31,2027.
III.	6:15 PM	Approve Previous Select Board Meeting Minutes: December 2, 2023 (Annual Town Meeting Preview Meeting); April 16, 2024
IV.	6:20 PM	Discuss and Approve Early Voting Hours for November 5, 2024
V.	6:25 PM	Town Manager's Report
VI.	6:35 PM	Chair's Report
VII.	6:40 PM	Select Board Liaison Reports
VIII.	6:50 PM	Discuss and Vote to Approve Verrill Farm Pavillion Project Presenter: Stephen Verrill, Owner; Delia Kaye, Natural Resources Director

IX.	7:05 PM	Discuss and Approve Bond Sale Authorization Presenter: Elizabeth Rourke, Assistant Town CFO
X.	7:15 PM	Common Victualler Application for Mark Pesce of the Pesce Network for a new Dunkin location at 794 Elm Street Presenter: Nicole Sullivan, Project Manager for the Pesce Network
XI.	7:20 PM	Discuss and Approve Change of Manager Liquor License Application for Nosh by Concord Market Presenters: Attorney James White and Keir Weinberg, Proposed Manager
XII.	7: 25 PM	Update from Recreation Director on Rec Revolving Fund and Beede Enterprise Fund Presenter: Jessica Porter, Assistant Town Manager; Leigh Jackson, Recreation Director
XIII.	7:40 PM	Discuss and Vote to Accept Updated App#16 Flag Raising Policy Presenters: Wendy Rovelli, Cameron McKennitt; Flag Raising Policy Committee
XIV.	7:50 PM	Discuss Town Manager’s Annual Evaluation Compilation Presenter: Jessica Porter, H/R Director
XV.	8:10 PM	Discuss and Accept FY25 Town Manager Goals Presenter: Kerry Lafleur, Town Manager
XVI.	8:20 PM	Request for Extension for Dog Arbitration Update Presenter: Kerry Lafleur, Town Manager
XVII.		Adjournment

**Times are approximate and subject to change*

Upcoming Meetings:

Monday, September 30, 2024; (RTE Forum)

Monday, October 7, 2024

Monday, October 21, 2024



The Town of Concord endeavors to make public meetings accessible to all members of the community. To request a meeting accommodation or modification, please contact our ADA Coordinator Jessica Porter at jporter@concordma.gov or at 978-318-3028. Please make any requests for accommodation or modifications at least two (2) business days prior to the scheduled meeting.



Concord Select Board Meeting
AGENDA ACTION REQUEST

Monday, September 23, 2024

2

Consent Agenda

Requested by: SB Chair

Action Sought: Approve

Proposed Motion(s)

Move to Approve Consent Agenda

Additional Information

Board Action

<i>Motion</i>	<i>Second</i>	<i>In favor</i>	<i>Opposed</i>	<i>Disposition</i>

**Town of Concord
Select Board
Minutes
Monday, August 19, 2024**

Pursuant to notice duly filed with the Town Clerk, the Concord Select Board convened in a meeting both in-person at 22 Monument Square on the 2nd floor in the Public Hearing Room and via Zoom at 6:00 PM on Monday, August 19, 2024.

Call to Order

Select Board Chair Mary Hartman called the Joint School Committee, FinCom, and Select Board Meeting to order at 6:00 PM

Present were Mary Hartman, Chair; Mark Howell, Clerk; Terri Ackerman, Cameron McKennitt, and Wendy Rovelli

Confirming a quorum has been met with the Chairs for the Concord School Committee, Concord-Carlisle Regional School District, and FinCom.

Select Board Chair, Ms. Hartman thanked the attendees and staff for all their hard work that has taken place to make this Joint Meeting happen.

Ms. Hartman opened the discussion and introduced Town CFO, Anthony Ansaldi. Mr. Ansaldi presented FY26 Capital Planning, highlighting the Capital Planning Task Force Recommendations.

Mr. Ansaldi discussed the Capital Improvement Plan (CIP) Tiers reflecting the Current Tier ranges, as well as proposed additional Tier structure. Discussing the development for future consideration, the funding of free cash policy to align with DOR best practices and limit the use of free cash to funding one-time expenditures. The presentation continued with an outline of the timeline for the capital plan, highlighting the past 5-years funding of prior capital plans.

Mr. Ansaldi stated that there has been some good progress in funding some many needed capital projects for the town. Further emphasizing the need for a unified capital plan that prioritizes all needs across the town and schools. Mr. Ansaldi sought support for the proposed policy from the Select Board.

Proposed timeline: November 18, 2024 – 1st Draft of the CIP Presentation
 December 16, 2024 – Final CIP Presentation

The goal is to present one Capital Article that will serve the town and schools.

Ms. Hartman opened the meeting to questions from the Select Board members.

-Ms. Ackerman thanked the School Committee, Superintendent, Finance Committee and CFO for collaborating in this process. She asked for further clarification of the Tier thresholds.

**Town of Concord
Select Board
Minutes
Monday, August 19, 2024**

- Wendy Rovelli commented on the process for budget build being considered for electric busses and the implications for the FinCom guideline process.

- Dr. Hunter appreciated the start of this discussion around the process.

Further questions were raised about larger projects being targeted for future years. School Committee Chair, Carrie Rankin, expressed appreciation for the progress in the process discussion with everyone present and continuing to uncover and improve on overall process and how this will affect guidelines for this year.

- Eric Dahlberg, FinCom Chair, confirmed that it will have an affect on the guidelines for this year.

- Dr. Hunter noted an error in one of the slides and pointed out that for F24 CPS came in under budget at \$495,000.

- Cameron McKennitt stated appreciation for the guidelines discussion and to hear more about spending to guidelines with respect to improving the process.

- Mark Howell discussed with Dr. Hunter the free cash process for stabilization funding.

Discussion continued with FinCom members on any large projects process. Further emphasizing the importance of cash capital definitions and clarification of this process going forward. Eric Dahl further stated for confirmation that the end goal is a unified capital plan. All agreed.

Ms. Hartman surveyed the Select Board and Committees for support for the policy proposed here today. Select Board members were all supportive of the process. Joint chairs of the FinCom and School Committee and Regional District will follow up after further discussion.

Eric Dahlberg clarified and emphasized that the FinCom sets the guidelines as part of their core responsibilities. Lois Wasoff expressed importance of providing input for the next iteration and will provide that as quickly as possible.

For full discussion please visit the Select Board webpage recording link: [Concord Select Board, Finance and School Joint meeting August 19 2024 \(youtube.com\)](#)

Preliminary Discussion of Letter of Interest for Peabody School site

Discussions moved to the upcoming transfer of the Peabody Middle School building to the town in early 2025 and the need for a clear plan for its future. Mr. Ansaldi highlighted the need for a

**Town of Concord
Select Board
Minutes
Monday, August 19, 2024**

timeline for the process and recommended a less restrictive request for Letters of Interest for the building, to allow a broader response and to engage in researching potential use.

Discussions continued with suggestions for use and the importance of uncovering issues in this process:

- Secure the building
- Physical fencing of the area
- Zoning
- Leaching Field

-Lois Warnoff expressed support in the process of discovery of the property value and parcel plan for land use. Additional comments by Don Kupka, expressing interest in having as many details discovered and included in the Letter of Interest prior to Town Meeting and final preparation.

Mark Howell asked for clarity on the responsibly to pay for building maintenance and expenses for FY25 after the students have moved and prior to transfer to the Town in July 2025. He also wanted to understand how the building expenses from July 1, 2025, would be budgeted.

Upon a motion duly made and seconded, it was UNANIMOUSLY **voted:** to adjourn joint meeting

Call to Order

Select Board Chair Mary Hartman called the meeting to order at 7:14 PM

Public Comment

Public Comment: Public Comment is limited to up to 15 minutes, with no more than 3 minutes allocated to any one speaker. Public Comment is limited to items that are not on the agenda.

Mr. Andrew Hercheck of 13 Garland Road while admitting he knew little about the Residential Tax Exemption, nonetheless, asked the Select Board to consider a subcommittee to better understand the intended goals of the program.

Ms. Hartman mentioned the Public Hearing scheduled for RTE on September 30, 2024. Recommending calling the Assessor's Office for tax bill detail. Also, adding that the RTE has had the least impact of increase on citizens FY23 vs FY24 tax bill.

Upon a motion duly made and seconded, it was UNANIMOUSLY voted: to Close Public Comment

Discuss Great American Outdoors Act Project Update-North Bridge Trail Work

Ms. Simone Monteleone, Superintendent of Minuteman National Historic Park provided an update on the Great American Outdoors Act Project with some changes to the rehabilitation

**Town of Concord
Select Board
Minutes
Monday, August 19, 2024**

schedule. Due to a delay, both sides of the North Bridge area will not have public access beginning on September 3, 2024, for 8-weeks to completion.

Consent Agenda

Consent Agenda

- a. Meeting Minutes: August 5, 2024
- b. Town Accountant Warrants: August 1, 2024; August 5, 2024; August 9, 2024
- c. One Day Liquor Licenses:
 - i. All Alcoholic Beverages for Sara Killelea of Concord Country Club for the Women's Golf Field Day on Thursday, August 29, 2024, from 12:00 PM – 9:00 PM at 246 ORNAC
- d. Select Board Committee Nominations:
 - i. Ellen Glendon, of 64 Stone Root Lane to the Conservation Restriction Stewardship Committee for a term to expire May 31, 2027
 - ii. Roseann Scimone, of 10 Dana Road to the Agriculture Committee as an Associate member for a term to expire May 31, 2027

Upon a motion duly made and seconded, it was UNANIMOUSLY **voted**: to approve the Consent Agenda without the Minutes for August 5th for edits and brought to next Select Board meeting for approval.

Select Board Appointments:

- i. Appointment of Terri Ackerman, of 89 Heaths Bridge Road to the Hanscom Field Advisory Committee (HFAC) as the Select Board Representative
- ii. Appointment of Katy Morris, of 119 North Main Street, Natick MA to the Economic Vitality Committee, APP#10 Section VII (g), for a term to expire May 31, 2027
- iii. Appointment of Pam Rockwell, of 1810 Main Street to the 2229 Main Street Advisory Task Force for a term to expire May 31, 2026, or end of the project.
- iv. Reappointment of Hilary Taylor, of 621 West Street, Carlisle, Concord, APP#10VII(g), Cultural Council for a term to expire May 31, 2027

Appointment and Reappointments of Election Workers for a term ending July 31, 2025, as included in the Select Board meeting packet.

Town Manager with Select Board Approval Committee Appointments:

- i. Appointment of Shriram Bharath, of 875 Old Road and Nine Acre Corner to the Board of Assessors for a term to expire May 31, 2027
- ii. Reappointment of Nancy Nelson, of 1695 Lowell Road to the Historical Commission as an Associate member for a term to expire May 31, 2025
- iii. Appointment of Ellen Quackenbush, of 206 Prairie Street to the Transportation Advisory Committee for a two-year term to expire April 30, 2026
- iv. Reappointment of Gary Kleiman of 57 Central Street to the Natural Resources Commission for a term to expire May 31, 2027
- v. Reappointment and re-stagger terms of Transportation Advisory Committee members:

**Town of Concord
Select Board
Minutes**

Monday, August 19, 2024

1. Nick Pappas, of 1743 Monument Street, APP#10VII (c), for a term to expire April 30, 2027
2. Phil Posner, of 223 Laws Brook Road #206 for a term to expire April 30, 2027
3. Dan Schragger, of 24 Mallard Drive for a term to expire April 30, 2027

Upon a motion duly made and seconded, it was UNANIMOUSLY **voted:** to approve the Consent Agenda without August 5th Minutes, and Appointments with exception to Reappointment of Hilary Taylor, of 621 West Street, Carlisle, Concord, APP#10VII(g), Cultural Council for a term to expire May 31, 2027.

Town Manager's Report

Town Manager Kerry Lafleur presented the Weekly Operations Report for the week ending August 16, 2024. Highlighting the updated webpage for Gerow Park, mitigation of tree plantings working with Friends of Warner's Pond to provide a plan for better view of the pond. Ms. Lafleur also mentioned the Road Maintenance Program webpage updates. The full Weekly Operations Report can be viewed on the Town Manager webpage of the Town website here: [Weekly-Operations-Report 8.16.24](#)

Chair's Report

Ms. Hartman reported on:

The Kickoff 250th Count Down event at the Concord Museum expressing appreciation to Select Board members who all attended. Ms. Hartman further expressed her thanks and appreciation to every member for their commitment and dedication to the town and their important contributions to the Select Board.

September 4th - 2229 Site Visit
September 7th - Ag Day
September 12th - MCI Forum
September 22nd - Stone Soup Dinner
September 25th - Ethics Training
September 30th - RTE Forum

In addition to the two Select Board meetings, Ms. Harman acknowledged there is a lot of work to do in September!

Select Board Liaison Reports

Mr. McKennitt reported on:

- The Flag Policy Subcommittee progress in preparing the Draft Flag Policy to vote on or further discussion after reviewing the options.
- The Light Plant board meeting and received some results of their survey's. Mr. McKennitt expressed his appreciation of some of the customer satisfaction levels overall.

Town of Concord
Select Board
Minutes
Monday, August 19, 2024

Some examples highlighting first call resolution is currently 76%. Similarly for Outage Satisfaction, 68%, which is much better than many benchmarks. Further expressing appreciation for such strong performance.

- Personnel Board is working through some adjustments, and challenges to align better with the market level.

Mr. Howell reported on:

- Personnel Board: Implementation of new pay schedule has been completed. Munis implementation in progress for January. The board also review the CMLP Market rate adjustments, CMLP has been providing great service, operating a full line crew short and this was a retention issue. The Personnel Board Charge has not been updated since 1985, and one more discussion is expected before it is ready to bring to Select Board meeting.
- Warner's Pond Task subgroups continue to meet to develop alternative proposal. Dam subgroup will present their preliminary findings from the dam removal subgroup at the September meeting. The Dredging and No Action subgroup are expected at future meetings. Last week, Town Manager presented Gerow status to the task force, and the Dam maintenance engineer about the condition and capability of the existing dam. Progress continues as the subgroups prepare their findings.
- MCI Advisory Board met preparing for the first public engagement meeting on Thursday, September 12th. Partnership with the Division of Capital asset maintenance from the state. The board will meet on Monday, August 26th as well as August 29th as it prepares to take a leadership role in this process.
- Middle School Building Committee project status continues to be on track with significant sight work to address traffic flow and parking before school opens.

Ms. Rovelli reported on:

- Trustees of Town Donations finished their FY 2024 distributions with the last 10 funds. Working on their 2025 estimates for September and looking to more outreach and documentation for the larger funds to share information on availability and accessing the funds if needed.
- Zoning Board of Appeals – voted approval of the Thoreau Club variance for a shared driveway to access the proposed multi-family development.
- Financial Audit Advisory Committee met last week to review the Audited Financials for the town. The committee will be putting together a draft letter of summary and recommendations from FY23. Continuing to review other committees going forward.
- Board of Health asks for participation in taking the health assessments which can be completed on the website.

Ms. Ackerman reported on:

- 250th Kickoff Countdown events, had a great turnout.
- India Day had a great turnout – 75 people expressed appreciated having that proclamation from the Select Board.
- 2229 Oversight Committee is doing an excellent job working with the cleanup contractor. On September 4 there is a tour where we will be viewing all the areas, barrier and cap on

**Town of Concord
Select Board
Minutes
Monday, August 19, 2024**

the holding basin. Also discovered an old septic system in another portion of the property that may be clean and not contaminated and able to be used.

Ms. Hartman reported on:

- Disposition of Real Estate is one of the goals of the Select Board. A tour of 249 Harrington Ave was organized by Ann Clifford. The Historical Commission may apply for CPC grants to update the assessment of the structure done in 2014 in order to gain a better understanding of what we are dealing with at this property.
- Housing Roundtable was well attended. The idea of an increase in the CPC surcharge was discussed. Currently at 1.5%, increasing to 2% with ½% specified for exclusively for housing. Need to determine if enabling legislation to earmark if possible and if the town supports such a movement.
- Affordable Housing development naming of the street dedicated to Terry Rothaermel who was a very tall and stalwart advocate for affordable housing here for many years.
- AG committee is preparing for Saturday, September 7th AG Day.
- Verrill Farm will host the Stone Soup Dinner, on September 22nd that pairs local restaurants with local farms. Proceeds go toward farms for programs and promotions.

Discuss and Vote on 120 Day Extension of Time to File Preliminary Assessment of Denial regarding Comcast contract negotiations – Expires August 21, 2024

Mr. Jason Bulger updated the Select Board on the process that the 120 Day Extension was provided by Comcast, and the negotiations have been moving forward but the deadline will expire and will be completed before end of year. Hoping to have an agreement

Upon a motion duly made and seconded, it was UNANIMOUSLY
voted: to approve the 120 Day Extension of Time to File Preliminary Assessment of Denial regarding Comcast contract negotiations – Expires August 21, 2024

Discuss and Vote on Change of Officers/Directors Liquor License Application for Concord Rod and Gun

Ms. Shannon McAndrew presented on behalf of Ms. Joyce. The application change in Officer/Directors completed annually. Gina Joyce is currently the president. This is a very standard application completed annually.

Upon a motion duly made and seconded, it was UNANIMOUSLY
voted: to approve Change of Officers/Directors Liquor License Application for Concord Rod and Gun.

Hear Recommendations from Concord Center Cultural Task Force and Vote to Dissolve the Task Force.

**Town of Concord
Select Board
Minutes
Monday, August 19, 2024**

Ms. Hartman provided a brief background on the appointment of the Concord Center Task Force and purpose of the task force and that they are now coming forward to the Select Board with their report and plan for the future of the committee.

Mr. Richard Fahlander, Chair, Concord Center Cultural District Taskforce recommended the Concord Center Cultural District be absorbed into the Concord Local Cultural Council and that staff support be provided to ensure resources are managed efficiently. The task for also recommends considering the West Concord Cultural District as well. Mr. Rogers, Chair of the Concord Local Cultural Council supported these decisions.

Upon a motion duly made and seconded, it was UNANIMOUSLY voted: to dissolve the Concord Center Cultural Task Force.

Ms. Hartman extended her appreciation to all the members of the Concord Center Cultural Task Force including Mr. Tooey Rogers, Chair, Concord Local Cultural Council; Mr. Richard Fahlander, Chair, Concord Center Cultural District Taskforce, and Ms. Mimi Graney, Economic Vitality Manager.

Discuss and Vote on Inter Municipal Agreement

Melanie Dineen, Public Health Director presented on the Regional Substance Use Prevention program and the proper use of the funding received. Ms. Dineen stated that in January 2023 they established the Concord Behavioral Health Collaborative, with a Charge established to determine program funding.

Ms. Dineen continued reporting on:

Proposed Budget for Opioid Settlement Monies:

- Initiatives included in this program are Annual high school Risk Behavior Survey to understand need of youth, and adults. Sudbury is the host community; seven community members will be overseeing collaboration in every town.
- Hiring of a Prevention Officer working with the schools as well as adults in the community to identify prevention and resources available for substance abuse.
- Narcan Training sessions are scheduled for next week.
- Proposed FY25 Draft Budget was presented to include Substance Use Prevention Coordinator salary, technology, estimating \$101,149.60.

Ms. Hartman invited Ms. Dineen back to the September 9th Select Board meeting with a written copy of the Intermunicipal Agreement requesting Select Board approval for Town Manager to authorize the agreement.

For further details of the Concord Behavioral Health Collaborative initiatives visit [Great Meadows Public Health Collaborative, MA](#) |

**Town of Concord
Select Board
Minutes
Monday, August 19, 2024
Discuss and Vote on Concord Middle School Building Charge Amendment**

Mr. Howell expressed appreciation of the decision that there are no additional members needed to at this time. A project like this it is valuable to keep experience and institutional knowledge close and taking no action on this Charge. Ms. Ackerman expressed her disappointment with this decision since Mr. Booth would have been an excellent addition to the membership. We will continue to be consistent with our processes going forward. Ms. Harman also expressed appreciation to Mr. Booth for his withdrawal and putting the interest of the town ahead of his own personal interest.

Discuss MBTA Communities Compliance Update

Ms. Hartman opened the discussion with Ms. Megan Zammuto, Deputy Town Manager.

Ms. Megan Zammuto introduced Elizabeth Hughes, Concord Town Planner to present the MBTA Communities Compliance update to the Select Board.

Ms. Hughes discussed the complexities and challenges of meeting the compliance model requirements for commuter rail communities, and that non-compliance would not invalidate the adopted zoning bylaw.

Ms. Hughes further discussed a brief presentation of the eight comments that the Town received from the Executive Office of Housing and Livable Communities pre-adoption letter and added clarification on the single contiguous district.

She provided an overview of the timeline that followed through July 2024, the Planning Board is discussing how to go about these next steps and how to meet the requirements, reviewing the GIS maps working with our GIS consultants.

Further discussion with the Select Board is recommended after the Planning Board reviews the model further. Ms. Rovelli will coordinate with the Planning Board to update the Select Board after further review, and present recommendations for moving forward.

A meeting was planned for September to update on the progress of the Planning Board's approach to the issue. The full presentation on the Select Board Meeting recording:

[Concord Select Board, Finance and School Joint meeting August 19 2024 - YouTube](#)

Upon a motion duly made and seconded, it was UNANIMOUSLY
voted: to approve the motion to **Adjourn** at 9:10 PM

Meeting Materials:

[August 19, 2024, Select Board Meeting Packet](#)

[Joint Select Board meeting August 19, 2024, Recording \(youtube.com\)](#)

**Town of Concord
Select Board
Minutes
Monday, August 19, 2024**

Action Noted:

- Develop timeline from Peabody site disposition, including RLI sent late December
- September Planning Board providing an update to the Select Board
- November 18th DRAFT CIP discussion - Joint Meeting
- December 16th Final CIP Presentation - Joint Meeting

DRAFT



Town of Concord
Finance Department
22 Monument Square
P.O. Box 535
Concord, Massachusetts 01742

To: Kerry A. Lefleur, Town Manager
From: Anthony M. Ansaldi, Jr, Chief Financial Officer
Subject: Concord Council on Aging Gift Account
Date: September 6, 2024

I am writing to request the inclusion of an item, with your acceptance on the upcoming Select Board's agenda. Fidelity Charitable Donor Fund Grant for the Concord Council on Aging Gift Account on behalf of the Leigh Family Gift Fund.

Concord Council on Aging Gift Account

\$1,000.00

45100073 4850
COAGIF
Concord Council on Aging Gift Account

Accepted: _____
Clerk

Date: _____



P.O. Box 770001
Cincinnati, OH 45277-0053

SP 01 000019 81825 H 1 ASNGLP
BQQQMZBBBBLZX
TOWN OF CONCORD
PO BOX 535
CONCORD, MA 01742-0535

000019 1/1

August 23, 2024

Dear Sir or Madam:

We are delighted to provide you with the attached check for \$1,000.00. This Fidelity Charitable Donor-Advised Fund SM grant was made at the recommendation of the Leigh Family Gift Fund, a donor-advised fund. ¹

This grant is made by Fidelity Charitable. Fidelity Charitable's donor recommends the grant be used for the following purpose (which does not constitute a restriction): **For the account of the Concord Council On Aging.** This grant is to be used exclusively for charitable purposes, and is not made for the purpose of influencing legislation. This grant is also subject to the "Grant Terms" on the next page. If you are unable or unwilling to meet these grant conditions, you must return these funds to Fidelity Charitable.

Should you choose to send a thank-you letter, the donor has requested it be sent to the following address. You should not, however, issue a tax acknowledgement to either the recommending donor(s) or to Fidelity Charitable.

John H. Leigh, 80 Deaconess Road, Suite 336, Concord, MA 01742-4179

¹ Fidelity Charitable is an independent public charity that sponsors a donor-advised fund program. In a donor-advised fund, Donors make irrevocable charitable contributions to Fidelity Charitable, and have the privilege of recommending grants to qualified public charities.

DCC_CEBQQQMZBBBBLZX_BBBBB 20240823 5700 P OP=DCCK Page 1 of 2

DCC_CEBQQQMZBBBBLZX_BBBBB 20240823 PLEASE FOLD AND DETACH AT PERFORATION BEFORE PRESENTING CHECK FOR PAYMENT

VERIFY THE AUTHENTICITY OF THIS MULTI-TONE SECURITY DOCUMENT. CHECK BACKGROUND AREA CHANGES COLOR GRADUALLY FROM TOP TO BOTTOM.

FIDELITY Charitable
Make more of difference

P.O. Box 770001
Cincinnati, OH 45277-0053
800-952-4438

PAYABLE AT: THE BANK OF NEW YORK MELLON
EVERETT, MA 02149
53-292/113

14739508
August 23, 2024

PAY TO THE ORDER OF TOWN OF CONCORD

\$1,000.00

One Thousand & 0/100 DOLLARS

VOID AFTER 60 DAYS

[Signature]

⑈ 14739508 ⑈ ⑆ 011302920⑆ ⑈ 004936 ⑈



Concord Select Board Meeting
AGENDA ACTION REQUEST

Monday, September 23, 2024

3

Approve Previous Select Board Meeting Minutes: December 2, 2023: (Annual Town Meeting Preview Meeting); April 16, 2024

Requested by: SB Chair

Action Sought: Approve

Proposed Motion(s)

Motion to approve previous Select Board Meeting Minutes: December 2, 2023: (Annual Town Meeting Preview Meeting); April 16, 2024

Additional Information

Board Action

<i>Motion</i>	<i>Second</i>	<i>In favor</i>	<i>Opposed</i>	<i>Disposition</i>

**Town of Concord
Select Board
Minutes
December 2, 2023**

Pursuant to notice duly filed with the Town Clerk's Office, the Concord Select Board held a hybrid virtual public meeting at the Town House, Public Hearing Room, 22 Monument Square and via Zoom on December 2, 2023, at 9:00AM for the Annual Town Meeting Preview Meeting.

Present were: Henry Dane, Chair; Mary Hartman, Clerk; Terri Ackerman, Linda Escobedo, Mark Howell

CALL TO ORDER

Select Board Chair Henry Dane called the meeting to order at 9:00AM.

Ms. Hartman confirmed that all members were present.

WELCOME & OVERVIEW

Chair's Remarks

Select Board Chair Henry Dane began the meeting of the Select Board by stating that the meeting was convened to primarily vote on opening the Town Meeting Warrant for the 2023 Annual Town Meeting. Mr. Dane stated that the session would serve as a preview meeting, aimed at providing information and allowing members of various Town Boards and Committees, as well as the public, to share and learn about upcoming proposals and challenges. Chair Dane spoke to the Town's recent administrative restructuring, financial strains due to capital expenditures, and significant housing developments that could impact the Town's budget and administrative resources. Mr. Dane also remarked that the Select Board would be discussing changes to the budgetary process and the proposal of a joint capital planning program.

Vote to Open the Annual Town Meeting Warrant on Saturday, December 2, 2023 at 9:00AM and close the Warrant on Wednesday, January 3, 2024 at 4:00PM

Upon a motion duly made and seconded, it was **UNANIMOUSLY voted:** to open the Annual Town Meeting Warrant on Saturday, December 2, 2023 at 9:00AM and close the Warrant on Wednesday, January 3, 2024 at 4:00PM.

Roll Call Vote:

Mr. Dane – Aye

Ms. Hartman – Aye

Ms. Ackerman – Aye

Ms. Escobedo – Aye

Mr. Howell – Aye

TOWN MODERATOR

**Town of Concord
Select Board
Minutes
December 2, 2023
Moderator's Remarks**

Ms. Carmin Reiss, Concord Town Moderator was the first person scheduled on the Agenda to make a presentation. Ms. Reiss discussed the upcoming MBTA Community Zoning Bylaw Amendment, which is anticipated to be a high-interest topic at the 2023 Annual Town Meeting. Ms. Reiss mentioned the possibility of scheduling it as the first item on the Agenda for ATM, depending on the community's interest post-hearings. Additionally, Ms. Reiss talked about exploring the feasibility of using the Harvey Wheeler Community Center as a second location for Town Meetings, highlighting the need for a cost-benefit analysis due to the additional staffing and limited extra capacity this option would provide.

Article to consider the formation of a Town Meeting Study Committee

Ms. Reiss introduced a proposal for forming a committee to study the Town Meeting process, an exercise last done in 1997, aimed at improving the process based on new observations and data. This proposal would include an option for residents to volunteer for the committee electronically.

FINANCE COMMITTEE

Overview of the FY25 CPS Operating Budget

Eric Dahlberg, Chair of the Finance Committee voiced the observations from the Finance Committee related to the residential tax exemption and the financial strain caused by recent tax increases. Mr. Dahlberg urged the Town to consider the financial impact of developing Warrant Articles for the upcoming Town Meeting, which would impose additional taxes on residents. Mr. Dahlberg made a presentation on the Town's financial situation, highlighting the budget process, guideline metrics established for Town and School budgets, and the expected revenue increase of approximately \$3 million or 2.22%. Mr. Dahlberg stated that the Finance Committee recommended a 3.7 million increase in guideline spending, which represents three-quarters of the overall money spent on Town services and Schools. This recommendation translates to an estimated 3.65% tax increase on the median value house, not including potential tax increases from the third phase of borrowing for the Concord Middle School Building Project. Mr. Dahlberg emphasized the challenge of balancing the need for services with the financial burden on residents and mentioned the possibility of facing 2.5 overrides in the coming years due to limited financial capacity. Mr. Dahlberg's presentation concluded with a discussion on the projected impact of the guidelines on property taxes and the importance of considering both operating budgets and capital spending in financial planning.

SCHOOL DISTRICT

Concord Public Schools Operating Budget

Dr. Laurie Hunter, the Superintendent of Concord Public Schools (CPS), provided updates on the School Committee's considerations for upcoming budget proposals in the early stages of the process. Dr. Hunter stated the CPS operating budget for FY25 is proposed to increase by 3.45% over FY24, with ongoing discussions planned for December 2023. Dr. Hunter remarked that the

**Town of Concord
Select Board
Minutes
December 2, 2023**

recommended budget includes considerations for teacher bargaining, strategic planning, mental health services, special education, and a reduction in out-of-district students.

Concord Public Schools Capital Budget

Dr. Hunter stated that the School Committee had concentrated a focus on CPS capital spending, with a traditional allocation of \$900,000 from the Town Manager's budget, and efforts to reconcile different tiers of spending. A facility study across the three elementary schools and the Ripley Building is underway to plan for future needs. Dr. Hunter stated the High School operating budget proposal is \$39 million, with Concord's assessment at \$23.2 million, including a debt assessment. The operational increase is proposed at 3.37%, with a focus on efficient staffing and budgeting. The overall assessment comparison for Concord shows a 4% increase, attributed to a slight uptick in enrollment. Dr. Hunter informed the Select Board that discussions with the School Committee and Finance Committee would take place in the coming weeks.

Concord-Carlisle Regional School District Budget

Ms. Hartman highlighted that there is confusion regarding the use of \$900K initially intended for school maintenance and equipment, and expressed concern that the funds may be getting mixed with operating expenses and plans to investigate whether the funds are dedicated to debt or are being used to subsidize operating costs. The intention to clarify the use of these funds and align on their approach is emphasized, with further discussion expected at the 2023 ATM.

Article regarding the Amenities Building at Concord-Carlisle High School

Dr. Hunter stated that the Regional School Committee has voted to propose a Warrant Article for borrowing funds to construct and design an amenities building at Memorial Field, primarily consisting of restrooms and a small concession stand. This initiative addresses the current use of non-compliant portable toilets and the lack of permanent facilities since the completion of the high school project. The proposed budget for this project is \$2.3 million, an increase from an initial feasibility study conducted four years ago, pre-COVID. The School Committee aims to prevent further cost increases and meet compliance standards.

The conversation developed around planning for the transfer of custody of the Peabody School, potentially to the Select Board, in relation to a target move-in date of February 2025. There was some question as to when to introduce an article for this transfer at the Town Meeting, possibly in April 2024 following the move-in. Ms. Ackerman mentioned that most school committees typically vote to surplus a building when it's ready to be surplus, indicating that the earliest this could happen would be at the Town Meeting in 2025, shortly after the move-in date.

PUBLIC WORKS COMMISSION

**Water System Improvements: Nagog Pond Infrastructure Improvements
and PFAS Mitigation**

Alan Cathcart, the Director of Concord Public Works, addressed the need for significant

**Town of Concord
Select Board
Minutes
December 2, 2023**

investments in the Town's water and stormwater systems. Mr. Cathcart outlined the planning efforts and studies conducted over recent years, highlighting the necessity for a \$50 million investment in water treatment facilities to meet Safe Drinking Water Act standards. This investment is expected to double the average cost of water service for residents to about \$1,500 per year over the next decade.

Article to Create a Stormwater Management Enterprise Fund

Additionally, Mr. Cathcart discussed the underinvestment in stormwater infrastructure, emphasizing the need for \$1 to \$2 million annual investments to maintain and improve the system. Mr. Cathcart proposed the establishment of a stormwater utility funded by fees, with further details to be discussed in an upcoming meeting. The initiatives aim to address both immediate and long-term needs for water and stormwater management in Concord, considering the community's holistic benefit.

PERSONNEL BOARD

Personnel Bylaw Amendments

Bill Mrachek and Liz Cobbs, Co-Chairs of the Personnel Board, presented two Warrant Articles at the meeting. The first Article discussed was the Personnel Board classification, a recurring item at Town Meeting, involving job title additions, deletions, and salary range assignments. The second, more significant change, involved drafting a new Personnel Bylaw, which is still in the process of being finalized. The new Bylaw aims to update the personnel system based on recommendations from a study task force, public comments, and Select Board recommendations, with a presentation to the select board planned for December 18, 2023.

PLANNING BOARD

Linda Miller, Chair of the Planning Board, discussed upcoming Articles for the upcoming Town Meeting.

MBTA Communities Multi-Family Zoning Bylaw Amendment

Ms. Miller gave an overview of the first Article, which aims to create five (5) overlay districts to comply with Massachusetts law, facilitating multifamily property development near MBTA commuter rail stations. This development is intended to support sustainability, diversity, equity, inclusion, and non-auto centric transit options.

Two-Family in Residence B Zoning Bylaw Amendment

Ms. Miller stated that the second recommended Article would propose allowing two-family dwellings by special permit in residence B zoning district, expanding on a previous bylaw for the residence C district.

Floodplain Conservancy District Zoning Bylaw Amendment

**Town of Concord
Select Board
Minutes
December 2, 2023**

Ms. Miller described the *Floodplain Conservancy District Zoning Bylaw Amendment* as a housekeeping amendment, addressing the Floodplain Conservancy District and corrections.

Site Plan Review Zoning Bylaw Amendment (may not move forward)

Ms. Miller described the *Site Plan Review Zoning Bylaw Amendment* as a housekeeping amendment, addressing misprints and inaccuracies in the Town's Zoning Bylaw.

Parking Requirements Zoning Bylaw Amendment (may not move forward)

AGRICULTURAL COMMITTEE

Article to petition changes to previously approved Home Rule Petition regarding a checkout bag charge

Liza Bemis, Co-Chair of the Agricultural Committee, discussed a proposed Article to amend a previously approved home-rule petition regarding a checkout bag charge. The amendment seeks to exempt farm stands and farmers market vendors from the 10-cent bag fee, which has not yet been implemented due to pending State approval. The exemption is proposed for several reasons: most farm stand businesses lack the POS systems needed to automatically add the bag charge to receipts, and many small farms, which only sell fruits and vegetables exempt from sales tax, would face difficulties as the bag fee requires collecting and reporting sales tax. Additionally, the imposition of a bag fee could stigmatize EBT card users at farm stands, as they would need to make an additional payment for bags. The discussion between Ms. Bemis and the Select Board called attention to the amendment as a response to the unique challenges faced by small farm businesses regarding the checkout bag charge.

DIVERSITY, EQUITY, AND INCLUSION COMMISSION

Article to consider naming the new Concord Middle School Ellen Garrison Middle School

Andrea Foncerrada and Joe Palumbo, Co-Chairs of the DEI Commission, discussed two (2) proposed Warrant Articles aimed at enhancing diversity and inclusion in Concord. Mr. Palumbo remarked that the first proposed Article would involve naming the new middle school after Ellen Garrison, a notable Concord-born African American who challenged segregation laws in the 19th century. Mr. Palumbo informed the Select Board that this move would mark the first time a public building in Concord has been named after a person of color. Members of the Select Board touched on the process and authority for naming public buildings and the importance of community input and collaboration in these initiatives.

Article to consider the formation of a Task Force to review and update the charges, policies, and protocols of the Historic Districts Commission and the Historical Commission

Mr. Palumbo stated that the second proposed Warrant Article suggests reviewing and potentially updating the charges of the Historic District Commission and the Historic Commission to better reflect 21st-century priorities, including diversity, equity, inclusion, and economic viability. The updates aim to ensure that Concord's history and heritage are more inclusive and representative

**Town of Concord
Select Board
Minutes
December 2, 2023**

of all communities.

CITIZEN PETITION

Town Meeting Voting Reform

Mr. Constantine Gonata, a Concord resident who has been living in the area for 20 years and works as a renewable energy and transmission consultant, presented a proposed Warrant Article. Mr. Gonata spoke to his concerns about voter participation in Town Meetings, comparing it unfavorably with state and presidential election turnouts. Mr. Gonata highlighted issues such as voter suppression and the inefficiency of the Town Meeting process, which results in low attendance and participation. Mr. Gonata proposed allowing votes to be taken in a special election in addition to Town Meetings to increase participation. Mr. Gonata also discussed the legality of this measure, referencing Massachusetts laws, and compared the role of attendees in Town Meetings to legislators, noting differences in compensation and absenteeism rates. Mr. Gonata's presentation suggested using online forums and resources to supplement Town Meetings and improve debate quality. Mr. Gonata emphasized the importance of increasing voter participation to ensure decisions reflect the will of all citizens, not just a small percentage.

Following Mr. Gonata's presentation, Mr. David Allen made a recommendation for another Warrant Article for remote participation at the Annual Town Meeting. Mr. Allen's talking points included the potential impact on Massachusetts legislation if Concord and other towns adopt this approach. Mr. Allen presented an idea for implementing a new system to facilitate participation in Town Meetings for those unable to attend in person due to illness, childcare responsibilities, or inability to drive at night. Mr. Allen described the system as a "third room," which aims to allow remote participation and voting, ensuring access and deliberation for all community members.

Mr. Gonata spoke to a proposal for a pilot trial and the use of a secure voting app that supports both attributed and secret ballots. The initiative was paused during COVID but is now being revisited, with considerations for cost and the implementation timeline being discussed.

ECONOMIC VITALITY COMMITTEE

Mr. Michael Lawson, representing the Economic Vitality Committee, proposed exploring a Warrant Article to relax regulations around temporary housing for the 250th anniversary of the American Revolution, acknowledging the need to navigate State regulations and the potential involvement of the Select Board or Planning Board in sponsoring the Article.

SOLAR IMPLEMENTATION TASK FORCE

Mr. Dean Banfield, Chair of the Solar Initiative Task Force, formed by a unanimous town meeting vote in April 2023, discussed the Task Force's efforts to increase solar arrays on Town land, aiming to meet the goals of the climate action plan by 2030. Mr. Banfield stated that two potential locations for solar arrays were identified: expanding existing arrays at the landfill, now feasible due to new mounting structures, and installing arrays at the Concord Carlisle High

**Town of Concord
Select Board
Minutes
December 2, 2023**

School campus, which is solar-ready. Mr. Banfield stated that the Task Force plans to propose funding through an article similar to last year's, which would require the Concord Municipal Light Plant (CMLP) to potentially issue debt, with the cost borne by ratepayers. There was confusion about the appropriate sponsor for the Article, with suggestions to involve the CMLP and ensure alignment with the bonding language. Ms. Hartman commented on the importance of structuring the Article to authorize raising money through debt, with the Town as the primary obligor but with the understanding that the CMLP would cover the costs. The discussion highlighted the need for careful coordination and clarification of the sponsorship and wording of the proposal.

ADJOURN

The meeting was adjourned at 10:49AM. The next Select Board meeting is scheduled for Monday, December 4, 2023 at 7:00PM.

MEETING MATERIALS

- [Meeting Agenda](#)
- [Meeting Packet](#)
- [Meeting Recording](#)

**Town of Concord
Select Board
Minutes
April 16, 2024**

Pursuant to notice duly filed with the Town Clerk's office, the Town of Concord Select Board held a hybrid virtual public meeting at the Town House, Public Hearing Room, 22 Monument Square and via Zoom on Tuesday, April 16, 2024 at 6:00PM.

Present were: Henry Dane, Chair; Mary Hartman, Clerk; Terri Ackerman, Linda Escobedo, Mark Howell

CALL TO ORDER

Select Board Chair Henry Dane called the meeting to order at 6:00PM.

Ms. Hartman confirmed that all members were present.

PUBLIC COMMENT

Ms. Mary Weinberg from Hillside Avenue expressed gratitude towards the Select Board for passing a real estate tax exemption and shared a poem dedicated to Chairman Henry Dane, celebrating his efforts in achieving a residential tax exemption for Concord, a feat not considered since 1979. Ms. Weinberg also read a piece by Ann Hunt Browning to emphasize the impact of the Select Board's collective actions.

Ms. Carrie Rankin, Concord School Committee member, speaking personally and not on behalf of the School Committee, addressed the need for enhancing the accessibility and inclusivity of Town meetings. Ms. Rankin highlighted the challenges faced by individuals with evening work schedules, childcare needs, or other commitments that disenfranchise them from participating.

Mr. Stephan Bader gave positive feedback on the Patriots Day celebration, specifically praising the atmosphere created by the availability of alcohol and outdoor seating at the Wright Tavern. Mr. Bader encouraged the Select Board to support similar future events.

Ms. Diane Proctor commented with a reminder to attendees about the availability of detailed discussions on Warrant Articles on *Minute Men Media Network's YouTube Channel*, encouraging people to watch them for better understanding before the Annual Town Meeting.

CONSENT AGENDA

- a. Meeting Minutes: April 1, 2024
- b. Town Accountant Warrants: April 3, 2024; April 10, 2024
- c. One Day Liquor Licenses:
 - i. Retroactive approval for Carole Wayland of 51 Walden Performing Arts Center for Wines & Malt Beverages Only on Saturday, April 13, 2024 from 7:00 PM – 11:00 PM at 51 Walden Performing Arts Center, 51 Walden Street
 - ii. Sara Killelea of Concord Country Club for All Alcoholic Beverages for the Men's Spring Member-Member Day 1 on Friday, June 21, 2024 from 11:00 AM – 11:00

**Town of Concord
Select Board
Minutes
April 16, 2024**

- PM at Concord Country Club, 246 ORNAC
- iii. Sara Killelea of Concord Country Club for All Alcoholic Beverages for the Men's Spring Member-Member Day 2 on Saturday, June 22, 2024 from 11:00 AM – 11:00 PM at Concord Country Club, 246 ORNAC
 - iv. Sara Killelea of Concord Country Club for All Alcoholic Beverages for the Member 3-Guest on Wednesday, July 10, 2024 from 12:00 PM – 10:00 PM at Concord Country Club, 246 ORNAC
 - v. Sara Killelea of Concord Country Club for All Alcoholic Beverages for the Ladies Invitational Day 1 on Thursday, July 18, 2024 from 11:00 AM – 8:00 PM at Concord Country Club, 246 ORNAC
 - vi. Sara Killelea of Concord Country Club for All Alcoholic Beverages for the Ladies Invitational Day 2 on Friday, July 19, 2024 from 11:00 AM – 8:00 PM at Concord Country Club, 246 ORNAC
- d. Committee Nominations:
- i. Allison Aley of 47 Warner Street to the West Concord Advisory Committee as a Full Member to complete an unexpired term of April 30, 2026
 - ii. Gregory Dorothy of 188 Border Road to the West Concord Advisory Committee as a Full Member (current Associate Member) for a term to expire April 30, 2027
 - iii. Sue Gladstone of 339 Heaths Bridge Road to the West Concord Junction Cultural District Committee for a term to expire May 31, 2027
 - iv. Alternate Members to the Historical Commission for terms to expire May 31, 2025
 - Lauren Meier of 36 Millrun Lane
 - Beth Van Duzer of 4 Granite Post Road
 - Douglas Ellis of 11 Concord Greene, Unit 1
 - Daniel Frost of 10 Orchard Road

Upon a motion duly made and seconded, it was **UNANIMOUSLY voted:** to approve the Consent Agenda without the April 1, 2024 Meeting Minutes.

Roll Call Vote:

Mr. Dane – Aye
Ms. Hartman – Aye
Ms. Ackerman – Aye
Ms. Escobedo – Aye
Mr. Howell – Aye

SELECT BOARD APPOINTMENTS

Upon a motion duly made and seconded, it was **UNANIMOUSLY voted:** to reappoint Lynda Ferrari of 20 Damon Street to the West Concord Advisory Committee for a term to expire April 30, 2027 and to reappoint Anne Fortier of 150 Old Pickard Road to the Board of Registrars for a term to expire May 31, 2027.

**Town of Concord
Select Board
Minutes
April 16, 2024**

COMMON CARRIER/LIVERY APPLICATION

Common Carrier/Livery Application for Joseph's Transportation

Mr. Joseph Albano, Joseph's Transportation appeared in front of the Select Board to provide clarification that the company's renewal was mistakenly filed as a new application. There was brief discussion amongst members of the Board on this matter.

Upon a motion duly made and seconded, it was **UNANIMOUSLY voted:** to approve a common carrier delivery license for Joseph's Transportation for the remainder of the 2024 calendar year.

SELECT BOARD MEETING CALENDAR

Review and Approve Select Board Meeting Calendar for remainder of 2024

Ms. Ackerman suggested to the other members to wait for the two new oncoming Select Board members before finalizing the upcoming meeting calendar. However, it was decided to adopt the proposed calendar and make any necessary adjustments later. The meeting time preference was briefly discussed, with a decision to finalize dates first and address meeting times later.

Upon a motion duly made and seconded, it was **UNANIMOUSLY voted:** to approve the Select Board Meeting Calendar for the remainder of 2024.

CONCORD ADVISORY BOARD CHARGE

Review Updated Draft of MCI Concord Advisory Board Charge

The Select Board then reviewed the updated draft of the MCI Concord Advisory Board charge, discussing the inclusion of ex officio non-voting members from the Transportation Advisory Committee and making a minor grammatical correction.

Upon a motion duly made and seconded, it was **UNANIMOUSLY voted:** to adopt the MCI Concord Advisory Board Charge with proposed amendments.

2023 ANNUAL TOWN MEETING

Initial Discussion of Select Board member speaking assignments for Annual Town Meeting

Mr. Dane reported that Ms. Carmin Reiss, the Town Moderator, had informed the Select Board that the Finance Committee and Select Board's recommendations on articles would be communicated to attendees. There was discussion on which members would speak on behalf of the Select Board for various articles, with time allocations of two (2) minutes per article mentioned. They went through the list of Articles, assigning members to speak on specific ones, such as Personnel Board Articles and the Town budget, emphasizing the importance of supporting the budget publicly.

**Town of Concord
Select Board
Minutes
April 16, 2024**

Select Board members discussed various Warrant Articles related to the upcoming Town Meeting, including the Concord Public Schools budget, a Warrant Article for borrowing funds to construct and design an amenities building at Memorial Field, and the use of paper ballots. Select Board members debated their positions on several other Articles, including those related to the Town Meeting Study Committee, the Climate Action Committee, and zoning changes proposed by the MBTA. The Board agreed on the need to prepare statements for certain articles, particularly those where they had unanimous or strong opinions. They also discussed the logistics of presenting their positions during the Town Meeting, including who would speak on behalf of the board for each Article. The conversation included considerations on the capital budget, the stabilization fund, and specific proposals such as a fossil fuel-free demonstration and a cell tower installation.

Ms. Ackerman stated that the Public Works Commission recommended no action on article 39 due to logistical issues. The Board planned to finalize the rest of their positions on several Articles in the formal meeting scheduled for Monday, April 22, 2024. There was also discussion about liaising with the Concord Preservation Committee and the need for clear communication regarding which Articles they would speak on, including articles 8, 9, 16, 17, 22, 26, 27, and 34. Ms. Ackerman highlighted the importance of addressing PFAS regulations and the water treatment facility project. Discussion on the [Fiscal Year 2024 Select Board Liaison Assignment \(PDF\)](#) concluded with plans to reconvene as a public hearing for the Special Town Meeting.

SPECIAL TOWN MEETING PUBLIC HEARING

**Joint Select Board and Finance Committee Special Town Meeting Public Hearing:
Article 1 – In-Town Utility Scale Battery**

Mr. Bulger of the Concord Municipal Light Plant (CMLP) began his presentation by specifying that Article 1 of the Special Town Meeting is for the borrowing of \$10.4 million to be paid by ratepayers and not taxpayers. Mr. Bulger's technical presentation included such topics as transformers and bus bars in the context of grid usage as well as the increase of solar growth within the Town. Mr. Bulger spoke of the following goals:

- 1) protect the grid
- 2) allow expansion of the grid
- 3) save emissions (reduce peak load)
- 4) save ratepayers money

Mr. Bulger also stated that with the impending closure of the MCI facilities, the existing power load would decrease significantly and could work against the delivery of services to the ratepayers.

Various approaches for addressing the goals were mentioned. The CMLP investigation focused on battery storage as the optimal solution for expansion. The use and size of a \$10.4 million battery allows CMLP to expand at a faster rate, better manage solar saturation, provides economies of scale, and offers better cash flow. These are considered all positive benefits for ratepayers. Mr. Bulger stated that rates would be higher during the first year (deficit year). After

**Town of Concord
Select Board
Minutes
April 16, 2024**

the first year a positive cash flow would be realized. A 4% borrowing rate is anticipated. Stated differently, Mr. Bulger said that ratepayers would see an increase of \$1/year for the first year with savings in all future years.

Alternative technical aspects and general questions were explored and discussed. Several questions addressed the following topics: the load as it pertains to in-town companies; the notion of rushing the decision; location of the grid; capability to even the use of the battery between storage and use; and, timing of discharge (AM) and storage during the day/overnight. The degree of difficulty in managing the system was mentioned especially during a four-month period of the year when uncertainty in usage creates subsequent uncertainty in costs. For CMLP there are two main goals: #1 grid stabilization, and #2 return of savings to rate payers.

The meeting was opened to public comment. Mr. Cameron McKennitt, an employee at National Grid, criticized the project's financial assumptions as overly optimistic and urged for a more conservative approach considering potential contingencies and a realistic assessment of financial returns.

Ms. Mari Weinberg suggested the need for visual aids such as maps and pictures to better understand the project's location and appearance, and requested detailed information on how the project's costs would affect users differently based on their energy consumption.

Mr. David Douglas questioned the accuracy of demand representation in the project's presentation and expressed skepticism about the project's emissions savings, pointing out it might result in a net increase in emissions.

Mr. Dinos Katas discussed the risks associated with the project, including regulatory and operational challenges, and suggested exploring third-party partnerships to mitigate these risks.

Mr. Dahlberg highlighted the potential for using solid-state devices to address current issues and the idea of reallocating resources from another project to gain experience with battery technology before fully committing to the proposed project. General public concerns were raised about the lack of a base case financial analysis and the need for transparency regarding the impact on user rates. Mr. Dane regarded the community's desire for more detailed information and reassurances about the project's feasibility, costs, and environmental impact. There was also more conversation touching on the need for careful scrutiny of project funding and the timeline for making the system operational by Fall 2025.

ADJOURN

Chair Dane adjourned the meeting at 8:18 PM.

MEETING MATERIALS

- [Meeting Agenda](#)
- [Meeting Packet](#)

**Town of Concord
Select Board
Minutes
April 16, 2024**

- [Meeting Recording](#)

DRAFT



Concord Select Board Meeting
AGENDA ACTION REQUEST

Monday, September 23, 2024

4

Discuss and Approve Early Voting Hours for November 5, 2024

Requested by: SB Chair

Action Sought: Approve

Proposed Motion(s)

Motion to Approve Early Voting Hours for November 5, 2024

Additional Information

Board Action

<i>Motion</i>	<i>Second</i>	<i>In favor</i>	<i>Opposed</i>	<i>Disposition</i>



Town Clerk's Office
22 Monument Square
Concord, MA 01742

Memo

To: Select Board
Cc: Kerry Lafleur, Town Manager
Board of Registrars
From: Kaari Mai Tari
Date: September 19, 2024
Re: Request to reduce Early In-person Voting Hours during the first week of early voting

Early Voting for the November 5, 2024 State Election will begin on Saturday, October 19th and continue until Friday, November 1st.

According to Legislation passed in July 2022, the first week of Early Voting may be reduced to 50% of normal office hours with approval of the Select Board no later than September 29th. (the last two pages of this memo contain the enabling Legislation and Elections Division Advisory)

On August 26, 2024, the Board of Registrars voted to recommend a 45% reduction of early in person voting hours during the first week of early voting as shown in the proposed schedule below.

Day	Date	Hours	#Hrs
Saturday	October 19, 2024	9:00am – 3:00pm	6
Monday	October 21, 2022	8:30am – 12:30pm	4
Tuesday	October 22, 2022	8:30am – 12:30pm	4
Wednesday	October 23, 2022	8:30am – 12:30pm	4
Thursday	October 24, 2022	8:30am – 12:30pm	4
Friday	October 25, 2022	8:30am – 12:30pm	4
Saturday	October 26, 2022	9:00am – 3:00pm	6
Monday	October 28, 2022	8:30am – 4:30pm	8
Tuesday	October 29, 2022	8:30am – 4:30pm	8
Wednesday	October 30, 2022	8:30am – 4:30pm	8
Thursday	October 31, 2022	8:30am – 4:30pm	8
Friday	November 1, 2022	8:30am – 12:30pm	4
Total proposed in-person early voting hours			68

Justification

Since 2020, Voting by Mail has increased in popularity leading to a decrease in voter turnout during the early in person voting period, particularly in the first week of early voting. In-person absentee voting will be available to voters during the hours that early in person voting is not offered. A table on the next page shows the turnout for in-person early voting since it was first offered to voters in 2016.

A similar request was granted by the Select Board for the 2022 State Election. During the reduced week of early in person voting, only one voter cast an absentee ballot at the counter.

Proposed Motion

To approve Early In-person Voting Hours for the November 5th General Election as included in the September 23, 2024 Select Board Meeting packet.

Thank you for your consideration.

	Sat	Mon	Tue	Wed	Thu	Fri	Sat	Sun	Mon	Tue	Wed	Thu	Fri	Total EV turnout	Total Election Turnout	% EV in person	
2016		422	450	404	471	402	465		451	456	440	671	836	5,468	11,447	48%	Absentee voting was the only alternative to in person early voting.
2018							157		169	189	226	261	199	1,201	10,191	12%	
Mar-20									227	149	239	213	456	1,284	7,750	17%	
Sep-20							77	55	78	83	71	71	47	482	7,280	7%	Early voting by mail was introduced during COVID.
Nov-20	329	306	266	212	228	230	135	130	213	197	231	179	293	2,949	12,391	24%	
Sep-22							74		43	34	54	52	51	308	5,099	6%	
Nov-22	49	40	31	32	23	33	82		116	68	110	131	120	835	9,732	9%	
Mar-24							25		31	28	23	22	26	155	5,250	3%	
Sep-24							14		18	14	9	15	18	88	3552	2%	

Enabling Legislation: MGL c. 54, s. 25B(b)(2)-(3)

(areas highlighted relate to Concord's voter population):

(2) Early voting in person shall be conducted:

(i) from the seventeenth day through the fourth day, inclusive, preceding a biennial state election and any city or town election held on the same day as a biennial state election; and

(ii) from the tenth day through the fourth day, inclusive, preceding any: (A) presidential or state primary or primary or election held pursuant to section 140 to fill a vacancy for senator or representative in congress; and (B) city or town election held on the same day as a primary or election enumerated in subclause (A).

(3) Early voting in person shall be conducted on weekend dates during the early voting period as follows: (i) for municipalities with less than 5,000 registered voters, for not less than 4 hours each weekend, with at least 1 day per weekend, for not less than 2 hours on a weekend day in which voting is conducted; (ii) for municipalities with not less than 5,000 registered voters but less than 25,000 registered voters, for not less than 6 hours each weekend, with at least 1 day per weekend, for not less than 3 hours on a weekend day in which voting is conducted; (iii) for municipalities with not less than 25,000 registered voters but less than 40,000 registered voters, for not less than 4 hours each weekend day; (iv) for municipalities with not less than 40,000 registered voters but less than 75,000 registered voters, for not less than 6 hours each weekend day; and (v) for municipalities with not less than 75,000 registered voters, for not less than 8 hours each weekend day. For each other day during the early voting period, early voting in-person shall be conducted as follows: (i) for municipalities with less than 5,000 registered voters the city council of a city or board of selectmen or select board of a town may, at a public meeting held not less than 20 days before the first day of the early voting period, vote to provide early voting hours of not less than 25 per cent of the usual business hours of the town clerk; (ii) for municipalities with more than 5,000 registered voters but less than 40,000 registered voters: (A) for the fifteenth day to the eleventh day, inclusive, preceding a biennial state election, the city council of a city or board of selectmen or select board of a town may, at a public meeting held not less than 20 days before the first day of the early voting period, vote to provide early voting hours of not less than 50 per cent of the usual business hours of the city or town clerk; and (B) for the eighth day to the fourth day, inclusive, during the usual business hours of each city or town clerk; and (iii) for municipalities with more than 40,000 registered voters, during the usual business hours of the city or town clerk. A city or town may, in its discretion, provide for additional early voting hours beyond the hours required by this paragraph.

Advisory from the Elections Division

In-Person Early Voting

In-Person Early Voting Dates

- State Election: October 19th – November 1st

In-Person Early Voting Hours

You are required to offer weekend and weekday hours based on the number of registered voters in your community.

The required minimum hours for weekends are:

Number of Voters	Required Weekend Early Voting Hours
0 - 4,999	At least 1 day per weekend At least 2 hours each day you are open At least 4 hours total each weekend
5,000 – 24,999	At least 1 day per weekend At least 3 hours per day you are open At least 6 hours total each weekend
25,000 – 39,999	At least 4 hours each weekend day
40,000 – 74,999	At least 6 hours each weekend day
75,000+	At least 8 hours each weekend day

For weekdays, the required minimum early voting hours will vary depending on the size of your community and at what point it is during the in-person early voting period. By default, the early voting hours are during your regular business hours; however, your city council, board of selectmen, or town council may have the option to limit early voting hours on certain days, if your community is small enough.

The required weekday early voting hours are:

Number of Voters	Required Weekday Early Voting Hours
0 - 4,999	At least 25% of regular business hours
5,000 – 39,999	State Election: Week 1: at least 50% of regular business hours Week 2: Regular business hours
40,000+	During your regular business hours

In order to limit your early voting hours, your board of selectmen, city council, or town council will need to vote to do so at a public meeting held no later than 20 days before early voting begins (September 29th).



Concord Select Board Meeting
AGENDA ACTION REQUEST

Monday, September 23, 2024

Reports and Updates

Requested by: SB Chair

Action Sought:

Proposed Motion(s)

None anticipated

Additional Information

Town Manager's Report
Chair's Report
Select Board Liaison Reports

Board Action

<i>Motion</i>	<i>Second</i>	<i>In favor</i>	<i>Opposed</i>	<i>Disposition</i>



Town of Concord

Weekly Operations Report

2024 Volume 32/September 6th, 2024

General Administration

MCI-Concord Public Hearing and Information Session

The Commonwealth of Massachusetts Division of Asset Management and Maintenance is hosting a public forum to discuss the disposition process for MCI-Concord on Thursday, Sept. 12, 2024 at 7 PM at the Town House and on Zoom. The public is welcome and encouraged to attend to hear the presentation and ask questions. Find more information at concordma.gov/MCI



Residential Tax Exemption Public Forum

The Select Board will host a hybrid public meeting on Sept. 30 at the Town House and on Zoom. The Residential Tax Exemption went into effect a year ago. A presentation reviewing the impact will be shown, with an opportunity to ask questions and provide comment.

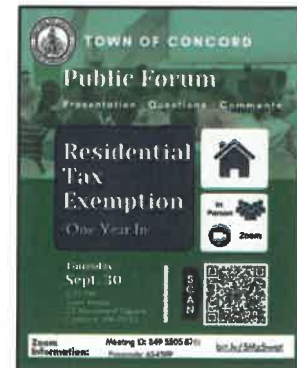

Election Report 2024: State Primary

- Total Registered voters as of August 24, 2024: **14,114**
- Total Voter Turnout: **3,552 (25%)**
- 26% voted in person on Election Day (911 voters)
- 74% of voters had cast their ballots before election day (**2,641** voters)
- **81** voters who requested ballots by mail decided to vote in person.



A total of **88** voters took advantage of State mandated Early in Person voting held over 6 days, totaling 42 hours, averaging 2 voters per hour. The highest turnout days were Monday and Friday with 18 voters each day.

Statistics narrative

25% of Concord's eligible voters cast ballots in the State Primary of September 3, 2024. Of the 3,552 voters participating, 74% (2,641 voters) had cast their votes prior to election day. Only 88 voters took advantage of the State-mandated Early In-Person voting held over 6 days, totaling 42 hours for an average of 2 voters per hour. The highest turnout days were Monday and Friday with 18 voters on each of those days.

Polling places saw 911 voters (26% of the total turnout) in person town-wide, of whom 81 had requested ballots but decided to vote in person.

Health Department

Mosquito Borne Viruses

Concord Health is in close communication with the Mass Dept of Health regarding the presence of the West Nile and EEE in regional mosquito populations. The Massachusetts Department of Public Health (DPH) announced on Friday one additional human case of Eastern equine encephalitis (EEE) and one additional human case of West Nile virus (WNV) in Massachusetts this year. The DPH raised the risk level to High in Acton and moderate in Concord. Concord residents are asked to take precautions and avoid contact with mosquitoes:

- Avoid outside areas with obvious mosquito activity
- Avoid being outside at dusk and dawn
- Remove standing water where mosquitoes can breed
- Use CDC recommended insect repellent
- Wear long sleeved shirts, long pants, and socks
- Repair window screens- keep mosquitoes out.

The Health Director has informed the area public and private schools of the DPH advisory, particularly regarding evening activities, and will continue to monitor and advise the community of any elevation in risk level. For more information see [Massachusetts arbovirus update | Mass.gov](#)

Police Department
Calls for Service

Thursday August 29th thru Wednesday September 4th, 2024

- Log items: 636
- Traffic enforcement: 39
- Motor vehicle stops: 45
- Motor vehicle crashes and/or exchanges: 10
- Arrests: 1

Officer Mailloux and Ofc. Sellards participated in the "National Night Out" at Hanscom Air Force Base on August 29th.

On August 29th, Captain Goldman, Lieutenant Landers, Sergeant Bordenca, and Inspector Holsinger attended the 250th Transportation Group meeting that was held at CPD.

Officers assisted the Lafayette Parade on September 2nd from the Concord Museum to Wright Tavern.

Detective Rodriguez and Detective Bordenca attended Surveillance Detection for Bombing Prevention training put on by the Department of Homeland Security at CPD on September 4th.

Inspector Paladino and Ofc. Simpson met with staff from Nashoba Brooks School on September 4th to go over school safety drills.

Economic Vitality

Cultural Council's Grant Opening

Apply for grant funding from the Local Cultural Council (LCC) for a variety of projects and programs in the arts, humanities, and sciences! Applications are now open, and are due by October 16th at 11:59 pm through the [Mass Cultural Council system](#).

For more information on the program, eligibility, the timeline, and how to apply:

<https://massculturalcouncil.org/communities/local-cultural-council-program/application-process/>



"Freedom's Silhouette" by Liz Helfer: A Public Art Celebration

In collaboration with the New England Foundation for the Arts (NEFA), the Metropolitan Area Planning Council (MAPC), and the Massachusetts Cultural Council, Concord is proud to present "Freedom's Silhouette," a captivating temporary art installation by Massachusetts-based artist Liz Helfer. This project is part of NEFA's state-wide "Making It Public" program, which supports diverse, inclusive, and equitable public artmaking across Massachusetts. These offerings are made possible thanks to funding from the Massachusetts Cultural Council to the Concord Center Cultural District. "Freedom's Silhouette" honors the enduring fight for freedom, drawing inspiration from the 250th anniversary of the American Revolution and the lives of 19th-century Concord residents Henry David Thoreau and Ellen Garrison. The artwork will be installed in Concord Center's Monument Square in mid-September and will remain on display through the 2025 celebrations.





Upcoming Events

Freedom Concert: Terry Borderline and the Suns

Join us for an electrifying performance by Terry Borderline and the Suns held at Monument Square on Saturday, October 5th from 3-5 pm. This seven-piece band will perform a set of original songs about freedom, spirituality, nature, and social justice, including an original piece inspired by Thoreau and Garrison. The concert will be followed by a 45-minute Q&A session.

Wright Tavern Pub Choir

Lift your voice to sing at Monument Square on Sunday, October 20th from 3:30-6 pm. Accomplished choir director and musician Tim Bongiovanni will teach participants a three-part harmony that they will perform by the sculpture. Enjoy refreshments and a beer garden at the Tavern as part of this unique musical event.

Youth "Upstander" Art Project

Explore Concord's African American history and connect past struggles for equality with modern movements on Saturday, October 5th from 11-1 pm or Wednesday, October 23rd from 3-5 pm at Monument Square. Presented by the Robbins House, this art project engages local youth in artmaking and dialogue about freedom and social justice.

Embodied Writing Workshop

Book coach Madeleine Eno and Boston Globe art critic & Substack writer Cate McQuaid present a free daylong workshop for writers and any creative souls who want to reinvigorate the connection between their bodies and their pens, giving voice to what freedom means to them. The workshop takes place in sites around Concord Center on

Saturday, September 28th. Space is limited. For more information and to apply, visit madeleine-eno.com/embodied/

Freedom Silhouette: Bridging Generations Through Film

This film project produced by Megan Carroll, Jane Howes, and Charley Kidd explores how three generations of a family encounter Thoreau and Garrison and reflect on the nature of freedom. The series of digital shorts will be distributed in November.

Concord's 389th Birthday

Thursday September 12th is the Towns 389th birthday and the Visitor Center will celebrate with Free Tours offered at 9 am, 12 pm, 1 pm, 3 pm, and 5 pm! The first large tour company (Collette Tours) is running our Beyond 1775 Package with 30 coach bus tours reserved in 2026. The Visitor Center is partnered with the Wright Tavern and Robbins House to offer this 3 hour bus tour with a private Concord Tour Guide.

Happy birthday Concord!
Free tours Sept. 12 to celebrate!

"It is ordered that there shall be a plantation at Musketaguid, and that there shall be six miles of land square belonging to it . . . And the name of the place is changed and henceforth to be called Concord."

—Order of General Court, 1635

Massachusetts Office of Travel and Tourism Spotlight

This week, the Massachusetts Office of Travel and Tourism (MOTT) wrote a feature on Concord250! Check out the full article here: <https://mailchi.mp/mass/industry-update-big-e-grants-revolutionary-fun?e=33975f9df4>

Concord Free Public Library

Reference Services

For June and July, Reference answered 724 reference questions, booked 447 meeting rooms, assisted 244 patrons with technology, and advised 14 patrons on reading choices. Eight patrons used the Library's notary service in June and July.

Reference ran a number of interesting programs in June and July, including a one-man show for Pride entitled "Pride the expiration date with Judah Leblang", a talk on the Isabella Stewart Gardner art heist, and a film screening of "Mona Lisa is Missing", which included a virtual Q&A with the filmmakers. Other programs included the weekly meditation series

with Lara Wilson, which was held on Zoom for each Thursday in June, as well as the monthly book discussion group and Cookbook Club.

Michelle John put together a wonderful pride display for June and a display on Olympic sports and athletes for July. Meanwhile, Barbara put together a display for Alzheimer's Awareness month, while Kate Keith-Fitzgerald put together a very popular display on books set in Paris.

Circulation

Circulation had 19,775 transactions and welcomed 111 new patrons to the CFPL family. Staff created book displays with the topics "Summer Blockbusters" and "Armchair Travel" and put up flags to celebrate the Summer Olympic Games Paris 2024! Also, patrons reserved 246 museum passes, with the New England Aquarium in first place by a significant margin, followed by the Museum of Fine Arts and the Museum of Science. Finally, circulation staff continue their involvement with professional development and the CFPL's Sustainability initiatives.



Fowler Library

On June 5, Fowler Library benefited from the first annual Concord Middle School Day of Service. Students enjoyed some animal therapy (they held the newly hatched chicks, a perfect balm for pre-finals stress!), painted book bricks to line the newly expanded pollinator garden in the backyard, and tested out the new corn hole set.

Fowler Library participated for the first time as a music venue for West Concord PorchFest, and a



cordoned off parking lot made for a perfect site for two acts, Blow My Own Horn and Timber Timbre.

For a second year, staff celebrated Pollinator Week in mid-June with support from the Pollinator Health Advisory Committee and the Natural Resources Division. Fowler held story times, transplanted seedlings from the Winter Seed Sow, and set up a self-guided garden tour of pollinator gardens throughout Concord. Staff also worked with Concord Public Works to begin the process of creating a new pollinator garden in the front yard. The first step, lasagna mulching, involved spreading a layer of cardboard directly on the grass and covering it with several inches of compost.



Reading Dragons and Rubber Duckies took over the summer, and staff have become adept at evolving dragons and helping the many summer reading participants navigate the popular program and find sufficient reading material to keep up with their dragon-like appetites.



Fowler Library joined the Main Library to celebrate ConcordPride, culminating for

Fowler in a well-attended Rainbow Crafting drop-in event during PrideFest on June 22nd, and staff offered weekly storytimes for Kaleidoscope, the youngest Concord Recreation Department campers. ArtScape at Bradford Mill curated another community art show, Still Life,

which opened in June and will be on display through the end of August.

During July, Fowler staff collaborated with the Sudbury, Assabet, Concord (SuAsCo) river stewards during their annual Riverfest celebration, working together for river storytimes, a River Lab, a craft during their July 20th event at the Old Manse, and a Fowler Afoot "River Walk" discussing *The Boatman: Henry David Thoreau's River Years* by Robert Thorson. To help promote their many free events, the summer reading program had a special "Stream Egg" that participants only got by attending a Riverfest program.



Jen Movitz offered Talk Yoga classes and a new well-attended series of Gentle Flow Yoga for adults. Stitch Circle attracted new members and welcomed interested crafters of all ages by holding a Beginning Crocheting class during one of their weekly meetups. Mothers Out Front focused



on wind power and the problems of single use plastics during Sustainability Labs in June and July.

Children's Library

This summer, Youth Services was thrilled to kick off our brand new Reading Dragons summer reading challenge for school-aged kids and the return of our popular Rubber Ducky Club for pre-readers! Members of the Rubber Ducky Club earned rubber duckies for each week of reading, and Reading Dragon Trainers earned dragon trading cards that grew and evolved into higher level dragons as they read. They were able to choose from a total of 16 different dragon eggs, each with a total of 4 evolutions. In summer 2023, 550 kids participated in summer reading challenges, and this year, a whopping 1,054 kids joined us for Reading Dragons and Rubber Ducky Club! Together, the children in our community read 30,450 days over the course of



the summer and collected over 192,000 dragon cards

In conjunction with Reading Dragons, Youth Services partnered with Concord

Pride in June and Riverfest in July to distribute special hidden dragon eggs that could only be found at Pride and Riverfest events! Several patrons reported attending to collect eggs and enjoyed discovering these events. Youth Services and Fowler staff also partnered with the



Concord250 Community to offer lanterns for the community to create and bring to celebrate 250 Days to the 250th Community Day. By the end of July, families at Main had created 50 lanterns to take to the event.

Youth Services also welcomed a variety of new and returning programmers:

- Musical Monday performer Julie Stepanek taught a class for families to learn to play the ukulele. Families learned plucking and strumming ukulele tabs and how to play 3 traditional tunes confidently.
- Kids went on an archeological adventure and excavated dragon figurines encased in “fossilized” dragon eggs, and then they constructed their own dragon eggs from clay and rhinestones.
- Buildwave led an interactive, hands-on building activity inspired by video games. Kids and their families participated in building challenges with “waves” of materials including LEGO, PlusPlus, and unique materials designed by Buildwave.



- Youth Services closed July with the first annual Worm Race! In this brand-new sporting event, kids each selected a worm “racer” and then competed to see which worm would move the farthest out of a 6 inch ring in one minute. Racers were brought home to the gardens of their trainers or released to enjoy a life of luxury in the Children’s Garden. Congratulations to the trainer of The Stow Speedster, who set this year’s record of exiting the ring in just 43 seconds!
- The Whalemobile visited, a life-sized inflatable humpback whale that nearly filled the Goodwin Forum and enchanted everyone who saw it! Families had the opportunity to go inside the whale with educator Michaela and learn about the anatomy of whales and the importance of whales in our ecosystem. Participants described the experience as “amazing” and “magical,” and several kids emerged with a new passion for caring for our oceans.



Innovation and Communications

The Workshop hosted hundreds of programs this summer, including a Pride Craft Party, gelli plate printing classes, a soldering workshop, and a Summer Paint & Sip that was a partnership with Youth Services! In addition, the Workshop ran its own Summer Maker Program, in which patrons received a stamp on a “loyalty card” for every visit they made to the Workshop—each full card earned them a special maker prize compatible with one of the Library’s maker tools.



It was a busy summer for Open Maker Hours, with more than 350 tool loans in June and July. The Innovation and Communication Team also expanded the Library’s accessibility infrastructure with a new mobile access cart that will allow the Library to offer assistive listening devices on request at programs hosted anywhere in the Main Library building, including storytimes and Workshop classes.

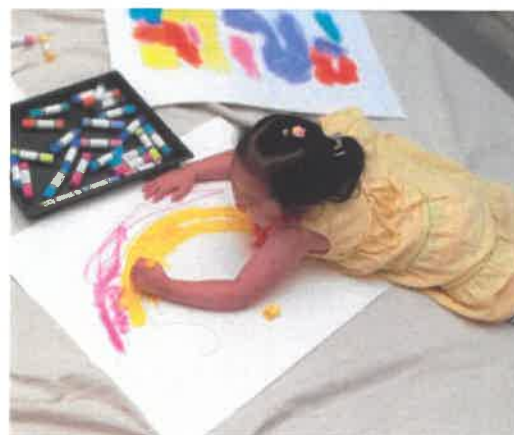

Special Collections

Special Collections served 236 patrons, including 197 on-site patrons, and answered 174 reference requests on-site, via phone, and email. Staff answered 85 requests to access archival records and manuscript materials. Patrons visited from 5 New England states, as well as from New York, North Carolina, California, Nevada, Colorado, Alabama, Indiana, Texas, Florida, Minnesota, Missouri, Illinois, Alaska, Canada, Japan, and Spain.

The Annual Gathering of the Thoreau Society resulted in many visits to Special Collections and a team from Florentine Films (aka Ken Burns Productions) reviewed multiple photograph and manuscript collections and scanned items that may be included in an upcoming documentary about Henry David Thoreau.

Special Collections created a very successful exhibition titled *Illustrated - An Exhibition of Children's Art*. Beginning in 1985, Children’s Library staff collected and framed drawings from authors and illustrators who visited the Library, showcasing local authors like Matt Tavares and D.B. Johnson and world-famous children’s authors such as Tomie dePaola and

Eric Carle. This was originally displayed in the Children's Room, a space that became the Goodwin Forum during the recent renovation and expansion. Special Collections housed the art in the Munroe Gallery for this special exhibition.



Town of Concord

Weekly Operations Report

2024 Volume 33/September 7-20th, 2024

General Administration

MCI Concord Redevelopment



The Division of Capital Asset Management and Maintenance (DCAMM) hosted a public forum and information session on Thursday, Sept. 12, 2024, at the Town House. Adam Baacke, Commissioner, DCAMM, and members of his staff, including Paul Lillehaugen, Senior Project Manager and Abby Vladeck, Director of Public/Private Partnership facilitated a public information session regarding the closure of MCI-Concord and the process to determine a plan for the future redevelopment of MCI-Concord. Commissioner Baacke remarked on the importance of the property and emphasized that the Healy administration has placed a priority on housing, sustainability, and opportunity for underserved

communities. This meeting marked the beginning of what will be a multiyear process which includes the development of the vision for the property, understanding and implementing the required zoning changes through the Town approval process, and the eventual issuance of an RFP for the redevelopment of the parcel.



Mary Hartman, Chair, Select Board gave brief remarks on behalf of the Town. Patrick McCurdy, Co-Chair, MCI-Concord Advisory Board, introduced the advisory board. After a brief presentation led by DCAMM, the floor was open to comments from the over 200 in attendance (approximately 80 in room and 165 on Zoom). The results of a brief survey distributed by DCAMM and the comments from the attendees at the meeting will contribute to the planning process.

Personnel New – CMLP

The Town of Concord is pleased to announce the appointment of Jason Bulger as the new Director of the Concord Municipal Light Plant (CMLP). Bulger, who has served as interim director since January, brings a wealth of experience and a strong commitment to the CMLP's mission, including as the Chief Technology Officer for the Town of Concord.

Following a rigorous search process, Bulger was selected from a highly competitive pool of both internal and external candidates. "We were impressed by the quality and experience of the applicants," said Town Manager Kerry Lafleur. "I want to thank everyone who participated in the search, especially those who served on our interview panels."

Bulger's leadership will focus on driving innovation, improving operational efficiency, and strengthening the CMLP's connection with the community. "Under Jason's direction," Lafleur continued, "we are confident in our ability to enhance our responsiveness to the community's needs and remain a trusted partner in achieving sustainability and clean energy goals."

The CMLP is currently finalizing transition plans and will announce an official start date soon. Please join us in congratulating Jason on his new role.

Residential Tax Exemption-Public Forum

A forum will be held on **Monday, September 30 at 6 pm** at the Town House and on Zoom. The residential tax exemption has been in place for a year. The meeting will include a presentation on the impact of the exemption on homeowners and town revenue, with an opportunity to ask questions and provide comment.

Town Clerk

Postcards have been mailed to voters who have not already applied to vote by mail for the November 5th Presidential Election. As of September 20th, 38% of eligible voters have

already applied to vote by mail (5,457 voters). Ballots will be mailed as soon as they arrive from the printer but no later than October 7th.

Other ways to vote:

- Vote early in person between October 19th and November 1st (excluding Sundays). Times to be determined.
- Vote on Election Day. Polls are open from 7:00 am until 8:00 pm.

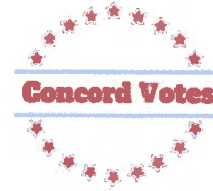

Important election deadlines:

- October 26th, 5:00 pm – Voter registration deadline
- October 29th, 5:00 pm – Vote-by-mail application deadline
- November 4th, 12:00 pm – In person absentee ballot application deadline
- November 5th, 8:00 pm – Deadline to receive vote-by-mail ballots in person or at the Town House drop box
- November 8th, 5:00 pm – Deadline to receive vote-by-mail ballots postmarked in the U.S. by November 5th
- November 15th, 5:00 pm – Deadline to receive vote-by-mail ballots postmarked outside the U.S. by November 5th

Public Safety

Police

Thursday September 5th thru Wednesday September 18th, 2024 (two weeks)

- LOG ITEMS: **1294**
- TRAFFIC ENFORCEMENT: **100**
- MOTOR VEHICLE STOPS: **122**
- MOTOR VEHICLE CRASHES AND/OR PAPER EXCHANGES: **18**
- ARRESTS: **2**

09/14-15/2024 – Officer Brady attended two NEMLEC Motorcycle Unit callouts, in Woburn and Lawrence.

09/12/2024 – Officer Burman and Officer Angulo attended Domestic Violence Services Network (DVSN) training at Lexington PD.

09/12/2024 – Sergeant Harrington and Sergeant McGonagle attended Supervisor Tactical De-Escalation training at Roger Williams University.

09/12/2024 – Sergeant Manchuso, Sergeant O'Connor, Officer Lordan, Officer Miller, and Officer Braga attended a suicide prevention training held at the station by the Department Mental Health Clinician.

09/08/2024- Officer Mailloux assisted NEMLEC Motor Unit with a callout to assist motorcyclists with Ride to Benefit Cancer.

09/08/2024- Department members participated in The Rotary Club 9/11 event, in remembrance of Mr. Al Filipov (former Rotarian). Officers received recognition for their lifesaving efforts in saving a young woman's life.

09/07/2024- Officers assisted with Ag Day.

09/07/2024- Officer Mailloux assisted NEMLEC Motor Unit with The Gold Star VFW Veterans Charity ride.

Public Health

Concord Community Health Needs

Concord is asking for community members to complete [the Concord and Maynard Community Health Needs Assessment Survey](#) to offer your opinions on what Concord can do to improve the health of the community.

Town Engineer

Road Work Updates

Main Street Paving

This week, another section of Main Street from its intersection with Coolidge Rd (located close to the railroad bridge) to the intersection with Elm St received the final pavement layer on Thursday. Main Street from Elm St to Sudbury Rd was completed in two sections in previous weeks. Work on the last section of Main Street in



the town center between Sudbury Rd and Monument Sq together with work on Monument Square itself will begin Sunday (9/15) night and continue for two weeks. It is expected that all construction will take place at night beginning around 8:00 p.m. and ending at 5:00 a.m. The contractor for this project is Lazaro Paving Corp.

Main Street/Walden Street Intersection Improvements

The concrete sidewalk, newly curb bump-outs and cobble accent areas are complete. This work was performed by Onyx Corp. who is subcontracting for Lazaro. Illuminated bollards proposed for added pedestrian lighting and to mark the location of the new bump-outs for vehicles approaching at night have been approved by the Historic District Commission and are being ordered. These have a long lead time and are expected to be installed later in the year. The light poles that provide overhead lighting were relocated by CMLP to illuminate the intersection better. The crosswalks which will carry a pattern will be installed following the repaving of the intersection.



Silver Hill Road Improvements, Phase 1

This project which includes the replacement of water mains, improvements to drainage and repaving of streets received bids for construction on Thursday. The work in this first phase covers Silver Hill Rd from Monument St to Turning Mill Rd, Cress Brook Rd, and Turning Mill Rd. Work is expected to start in October.

Highland Street

After reclaiming the street and completing the binder paving of half the length of the street, a significant blockage in the underground drainage pipe was discovered. The last several weeks were spent investigating the cause of the problem and designing the repairs. Work is being scheduled to resume soon.

Baker Avenue Culverts

Proper investigation of the cause of the sinkhole in the street and sidewalk was complicated by the pipes being submerged but has been completed. It was observed that

the joint where the metal pipe comes in at a vertical angle to the plastic pipe has failed. The culvert system is made up of three 30-inch parallel pipes, the middle of which has failed. The Engineering Division is working with a consultant to determine the design effort for the repair.

Council on Aging

Homecoming

It was homecoming Wednesday at the COA when over 80 senior residents came to chat, convene,



and break bread with long-time friends. At the first



Wednesday Lunch of each month, the COA salutes those who celebrate a birthday within that month.



Wendy Rovelli Reported:

Liaison

West Concord Advisory

- Continuing review of West Concord Master Plan - continue at next meeting 10/2

COA

- Close to finalizing a new logo emphasizing the HW building & Clocktower - looks very nice. Same artist who did WC electric boxes and Pride logo

Trustees of Town Donations (9/5)

- Finalized FY 2025 distribution amounts
- From a fund oversight perspective, looking to have requestors document use of funds. Grouped funds into tiers with the top funds coming to a future meeting and discuss the uses of funds. Mid tier will be asked to document uses in writing while some like scholarship funds will not have requirements due to the nature of the charter.

School Committee

- Shelter Totals: 49 total students: 6 CCHS; 2 preschool; 34 Willard; 2 Alcott; 5 CMS
- Goals - 4 categories; working to outline specific SMART criteria under each; intent is to review progress on a specific segment each meeting/month (TBD)
 - o Student achievement
 - o Community relations and outreach
 - o Budget
 - o School committee operations
- FY 25 Budget overages, mostly driven by OOD placements; Identified early and administration will monitor and discuss in quarterly budget reviews
 - o CCRSD \$-475K
 - o CPS \$-363K
- FY 2024 circuit breaker reimbursement amounts expected to be confirmed soon; school committee will decide how much of this reserve to use to offset FY25 expenses

Planning Board

- Approved (vote 5 for, 1 against) Blue Mercury Special permit for a retail formula business in the Concord Center Business District (Fatface location, A large retail vendor, does not compete with existing retail in the center, will make minimal storefront change and limit bright light exposure)
- Middlesex School - Approved Letter to ZBA for approved of special permit for a new athletics practice facility with a height waiver to 72 ft. 9 inches at 1400 Lowell Road
- MBTA Communities
 - o Compliance
- ☐ Waiting to get a meeting with EOHLC staff to review GIS recommendations (8 comments), Will raise question about leeway on contiguous requirement given 2 rail stations.
- ☐ Staff will be come up with 2-3 scenarios to address the contiguous requirement. Have a public session in January - get feedback on options and planning board would move forward with TM warrant article. In Nov/Dec PB meeting review/discuss the 3 options.
 - o Met with consultant to continue rules & regulations draft. In Oct have a staff meeting to review draft regulations and then have board review that draft Nov/Dec. Could use that same public forum to review proposal

Zoning Board of Appeals

- Middlesex - Special permit approved for height limit 72'9" for new athletic facility with planning board conditions of approval
- Thoreau Residence/Forest Ridge 40B - Developer planning to submit revised proposal, plan for presentation on Oct 30th, then further review of Dec 5th.
 - o 1st meeting can allow community to hear initial presentation
 - o Gives board a couple weeks to digest
 - o Meet off line with consultants before Oct 30 mtg



Concord Select Board Meeting
AGENDA ACTION REQUEST

Monday, September 23, 2024

5

Discuss and Vote to Approve: MDAR Co-Holder Form for Verrill Farm Pavillion Project

Requested by: SB Chair

Action Sought: Approve

Proposed Motion(s)

Motion to approve MDAR Co-Holder Form for Verrill Farm Pavillion Project

Additional Information

Board Action

<i>Motion</i>	<i>Second</i>	<i>In favor</i>	<i>Opposed</i>	<i>Disposition</i>



Wheeler

- 1. This will be a pavilion type structure. It will be closed on two sides to give protection from the northeast wind and rain. The other two sides will be open to provide a vista of our fields for present and prospective customers attending our events.**
- 2. The pavilion will be used primarily from late spring to mid fall, usually with food grown and prepared on the farm and a talk or discussion involving local agriculture.**
- 3. This will be 40ft x 60ft. It is replacing a 40ft x 40ft arched tent with a semi-permanent frame that has been in place for about 15 years.**
- 4. This will be a permanent post and truss structure with a concrete floor to be functional in rainy spells.**
- 5. The pavilion will cover 800sq.ft. more than the structure it is replacing. It will cover part of the same area, but will be somewhat closer to the main farmstand.**
- 6. The concrete floor will cover 2800sq.ft. About 160 sq. ft. of existing sidewalk will be removed.**
- 7. No new access is required.**
- 8. Electricity which exists in proximity will be the only utility.**
- 9. At Verrill Farm, we raise about 125 acres of vegetables and strawberries as well as 8 to 10 beef animals a year. Most of our production is sold through the farm stand as fresh vegetables or in our prepared meals. Additional produce is sold to greater Boston restaurants and several other farm stands. Surplus production is used by the Boston Area Gleaners.**

The pavilion is to provide better cover for our numerous events. Our signature events are:

Asparagus field trip and lunch, where people start in the field learning how asparagus grows and come back to the farm for a lunch with various asparagus dishes.

Strawberry Festival featuring strawberry shortcake and PYO berries.

Corn and tomato festival with many dishes to sample.

Fall Harvest Festival with pumpkins, games and food, with the proceeds donated to Emerson Hospital.

We host the annual “Stone Soup Dinner” where Concord farmers donate their produce to Concord restaurants that each prepare a selection for the dinner. There is an informative program on local agriculture and the proceeds are used to promote agriculture in Town.

Other events we have during the season include our own “farm-to-table” dinners, Ag in the classroom teachers, Cornell Club of Boston, Rotary, Chamber of Commerce, environmental grad students from Tennessee, birthdays, weddings. Etc. These events have our own food and most get information about the farm.

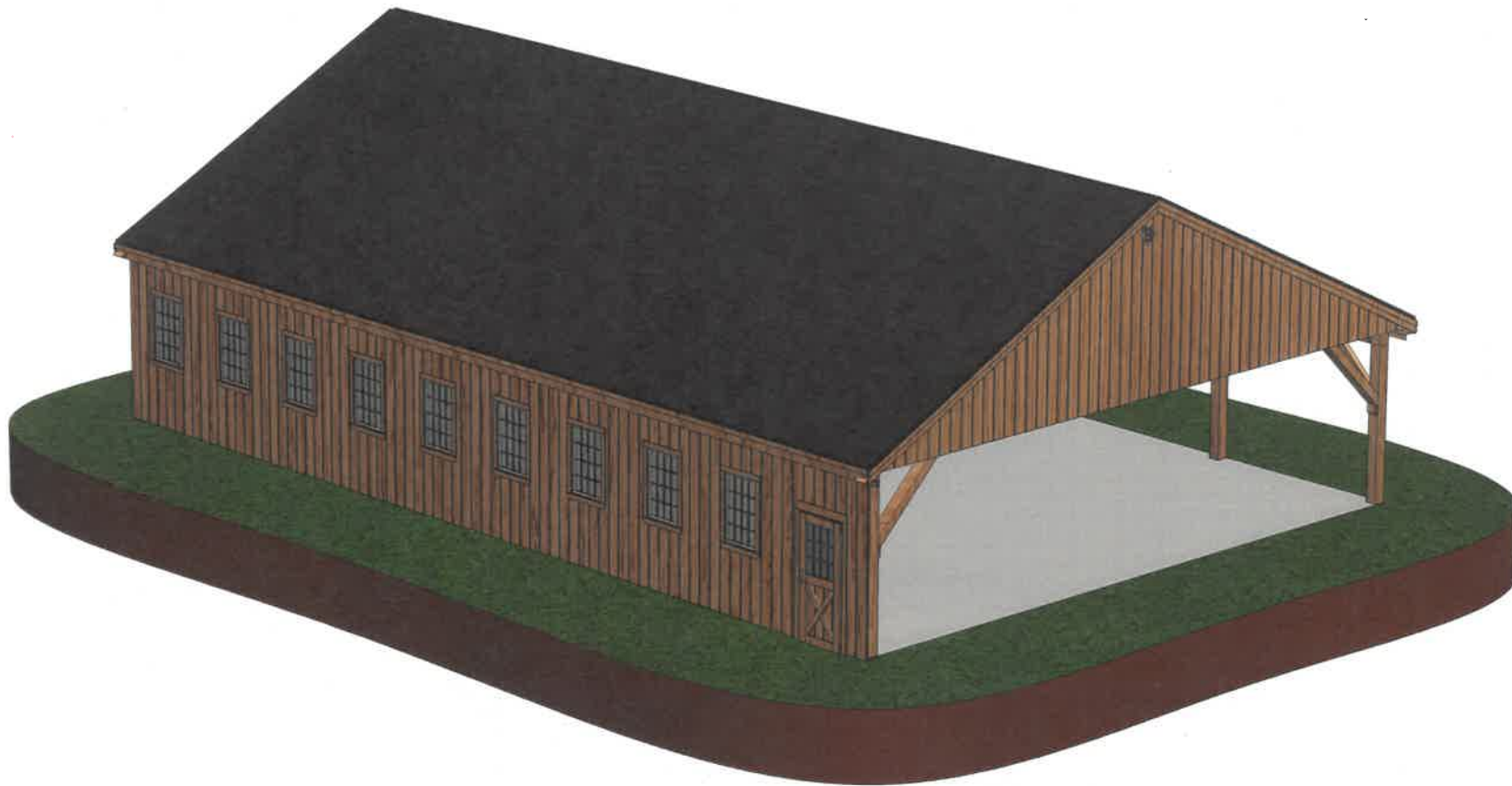

RENDERED ISOMETRIC - FRONT LEFT
SCALE 3/8" = 1" (ON 11x17 PAPER)

CUSTOMER APPROVAL SIGNATURE: _____

DATE: _____

SOLIDWORKS Maker Product. For Personal Use Only.

Circle B Barn Co.

- Equine Facility Specialists -

489 Neck Road
Lancaster, Massachusetts 01523
tel. (978) 368-8400
fax (978) 368-9130
www.circleb.com

ENGINEER DISCLAIMER
THE ENGINEER'S STAMP ON THIS DRAWING QUALIFIES THE STRUCTURAL DESIGN ONLY AND ASSUMES THAT THE FOUNDATION FOOTING BEARING SURFACE IS UNDISTURBED, OR PROPERLY COMPACTED, NON-ORGANIC SOIL WITH A MINIMUM BEARING ALLOWABLE OF 2000 PSF AND THAT ALL CONSTRUCTION WILL BE PERFORMED BY QUALIFIED CRAFTSMEN IN ACCORDANCE WITH THE 8TH EDITION OF THE MASSACHUSETTS BUILDING CODE. ON-SITE VERIFICATION OF CONSTRUCTION IS REQUIRED BY A QUALIFIED AGENT DURING DEMOLITION AND CONSTRUCTION TO VERIFY ASSUMPTIONS ARE CORRECT AND THAT CONSTRUCTION IS PROPERLY PERFORMED. IF THE CONTRACTORS OR OWNER'S RESPONSIBILITY TO ASSURE THAT THESE NOTIFICATIONS ON THE PROJECT PROGRESS IS PROVIDED SO THAT ADEQUATE PRESENCE OF QUALIFIED AGENT IS OBTAINED.

REV #	REVISION	DATE
0	REVISED CONSTRUCTION SET	03/01/2024

PROPRIETARY NOTICE
THIS DRAWING SHEET AND CONTENTS HEREIN ARE THE PROPERTY OF CIRCLE B. USE OF THE DRAWING'S CONTENTS OR DESIGN CONCEPTS FOR PURPOSES OTHER THAN ESTIMATING, DRAWING PREPARATION, AND/OR MANUFACTURING FOR CIRCLE B SHALL BE CAUSE FOR LEGAL RECOURSE BY CIRCLE B BARN CO INC.

Jennifer Veirill
One Wheeler Road
Concord, MA 01742

PROJECT	RENDERING
DATE	XXXX / XXXX
BY	TJM
DATE	7/21 / 2024

SHEET 2 OF 9

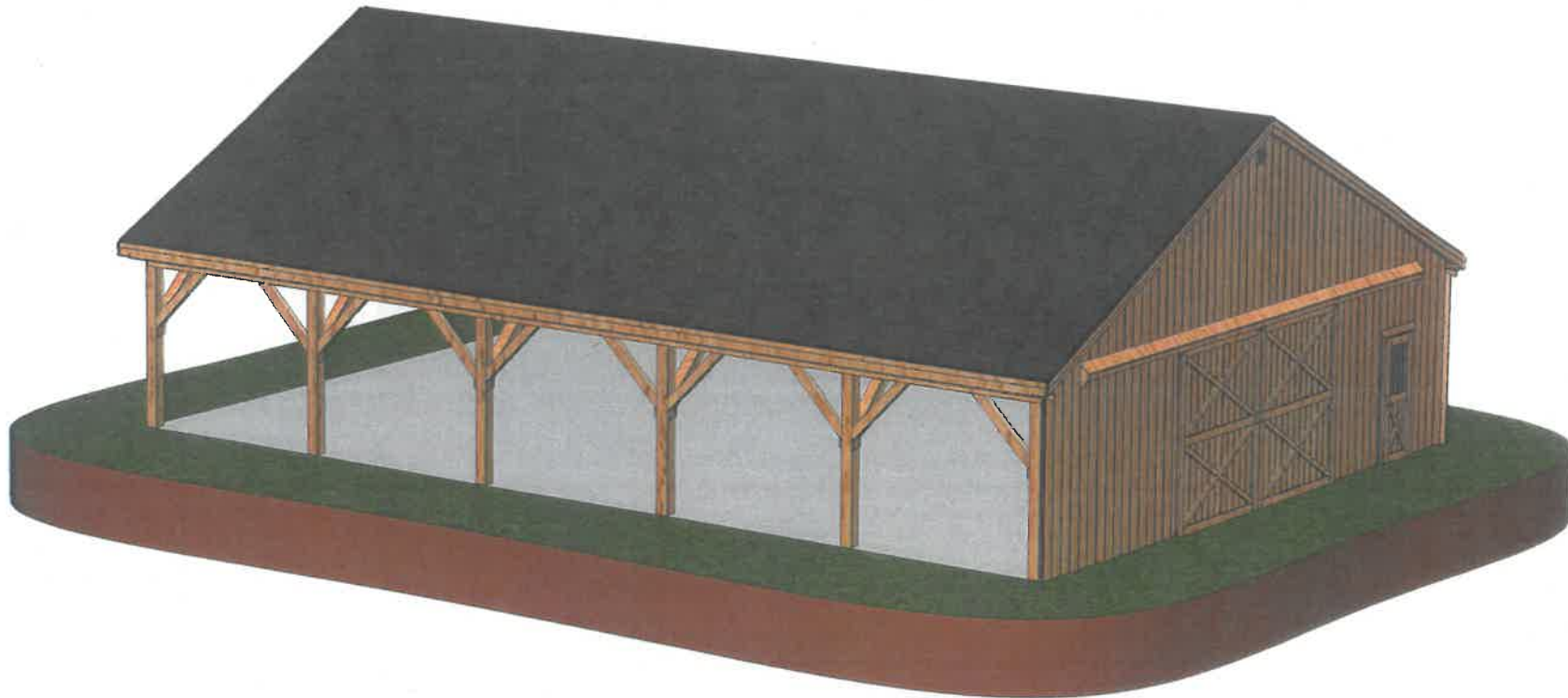

RENDERED ISOMETRIC - REAR RIGHT
SCALE 1/8" = 1" (ON 11x17 PAPER)

CUSTOMER APPROVAL SIGNATURE: _____

DATE: _____

SOLIDWORKS Maker Product. For Personal Use Only.



- Equine Facility Specialists -

489 Neck Road
Lancaster, Massachusetts 01523
tel (978) 368-8400
fax (978) 368-9130
www.circleb.com

ENGINEER DISCLAIMER
THE ENGINEER'S STAMP ON THIS DRAWING QUALIFIES THE STRUCTURAL DESIGN ONLY AND ASSUMES THAT THE FOUNDATION FOOTING BEARING SURFACE IS UNDISTURBED, OR PROPERLY COMPACTED, NON-ORGANIC SOIL WITH A MINIMUM BEARING ALLOWABLE OF 300 PSF AND THAT ALL CONSTRUCTION WILL BE PERFORMED BY QUALIFIED CRAFTSMEN IN ACCORDANCE WITH THE 8TH EDITION OF THE MASSACHUSETTS BUILDING CODE. ON-SITE VERIFICATION OF CONSTRUCTION IS REQUIRED BY A QUALIFIED AGENT DURING DEMOLITION AND CONSTRUCTION TO VERIFY ASSUMPTIONS ARE CORRECT AND THAT CONSTRUCTION IS PROPERLY PERFORMED. IT IS THE CONTRACTORS OR OWNER'S RESPONSIBILITY TO ASSURE THAT TIMELY NOTIFICATION OF THE PROJECT PROGRESS IS PROVIDED SO THAT ADEQUATE PRESENCE OF QUALIFIED AGENT IS OBTAINED.

REV #	REVISION	DATE
1	REVISED CONSTRUCTION	02/21/2024

PROPRIETARY NOTICE
THIS DRAWING SHEET AND CONTENTS HEREON ARE THE PROPERTY OF CIRCLE B. USE OF THIS DRAWING'S CONTENT OR DESIGN CONCEPTS FOR PURPOSES OTHER THAN ESTIMATING, DRAWING PREPARATION, AND/OR MANUFACTURING FOR CIRCLE B SHALL BE CAUSE FOR LEGAL RECOURSE BY CIRCLE B BARN CO INC.

Jennifer Verrill
One Wheeler Road
Concord, MA 01474

RENDERING
JOB # XXXX / XXXX
Drawn by TJM
Date 7/21/2024

SHEET 3 OF 9

ENGINEER DISCLAIMER
 THE ENGINEER'S STAMP ON THIS DRAWING
 QUALIFIES THE STRUCTURAL DESIGN ONLY
 AND ASSUMES THAT THE FOUNDATION
 FOOTING BEARING SURFACE IS
 UNENCUMBERED, OR PROPERLY COMPACTED,
 NON-ORGANIC SOIL WITH A MINIMUM
 BEARING ALLOWABLE OF 2000 P/SF AND
 THAT ALL CONSTRUCTION WILL BE
 PERFORMED BY QUALIFIED CRAFTSMEN IN
 ACCORDANCE WITH THE 8TH EDITION OF
 THE MASSACHUSETTS BUILDING CODE. ON-
 SITE VERIFICATION OF CONSTRUCTION IS
 REQUIRED BY A QUALIFIED AGENT DURING
 DEMOLITION AND CONSTRUCTION TO
 VERIFY ASSUMPTIONS ARE CORRECT AND
 THAT CONSTRUCTION IS PROPERLY
 PERFORMED. IT IS THE CONTRACTORS OR
 OWNER'S RESPONSIBILITY TO ASSURE THAT
 TIMELY NOTIFICATION OF THE PROJECT
 PROGRESS IS PROVIDED SO THAT
 ADEQUATE PRESENCE OF QUALIFIED AGENT
 IS MAINTAINED.

REV #	DATE	REVISION

PROPRIETARY NOTICE
 THIS DRAWING SHEET AND CONTENTS
 HEREON ARE THE PROPERTY OF CIRCLE B.
 USE OF THIS DRAWING'S CONTENT OR
 DESIGN CONCEPTS FOR PURPOSES OTHER
 THAN ESTIMATING, DRAWING,
 PREPARATION, AND/OR MANUFACTURING
 FOR CIRCLE B SHALL BE CAUSE FOR LEGAL
 RECOURSE BY CIRCLE B BARN CO INC.

Jennifer Verrill
 One Wheeler Road
 Concord, MA 01474

DESCRIPTION	FOUNDATION PLAN
DATE	XXXX / XXXX
DESIGNED BY	
CHECKED BY	
DATE	7/21/2024
SHEET 5 OF 9	

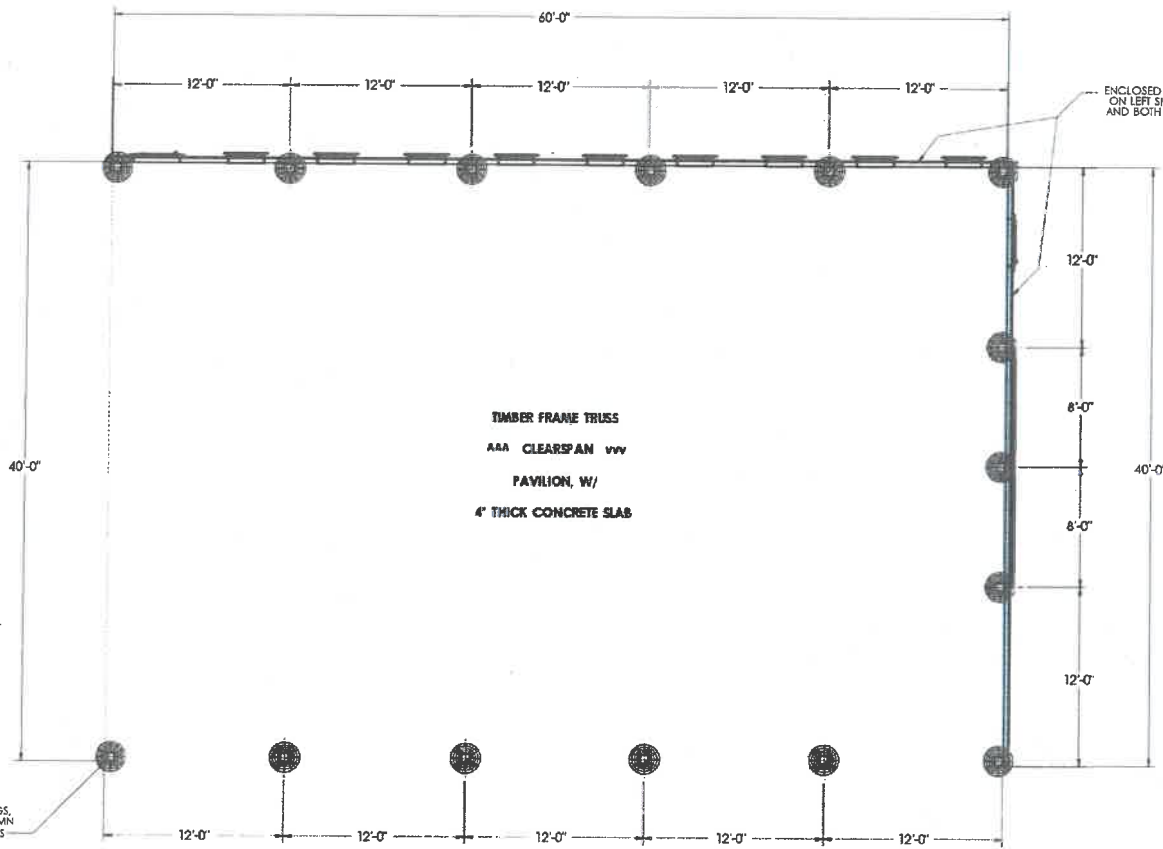

PAVILION FOUNDATION PLAN
 SCALE: 1/4" = 1' (ON 11x17 PAPER)

CUSTOMER APPROVAL SIGNATURE: _____ DATE: _____

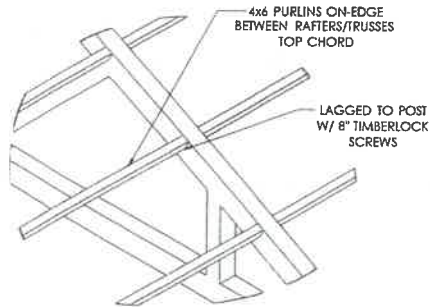

ROOFING PURLIN DETAIL
SCALE 1/2" = 1" (ON 11x17 PAPER)

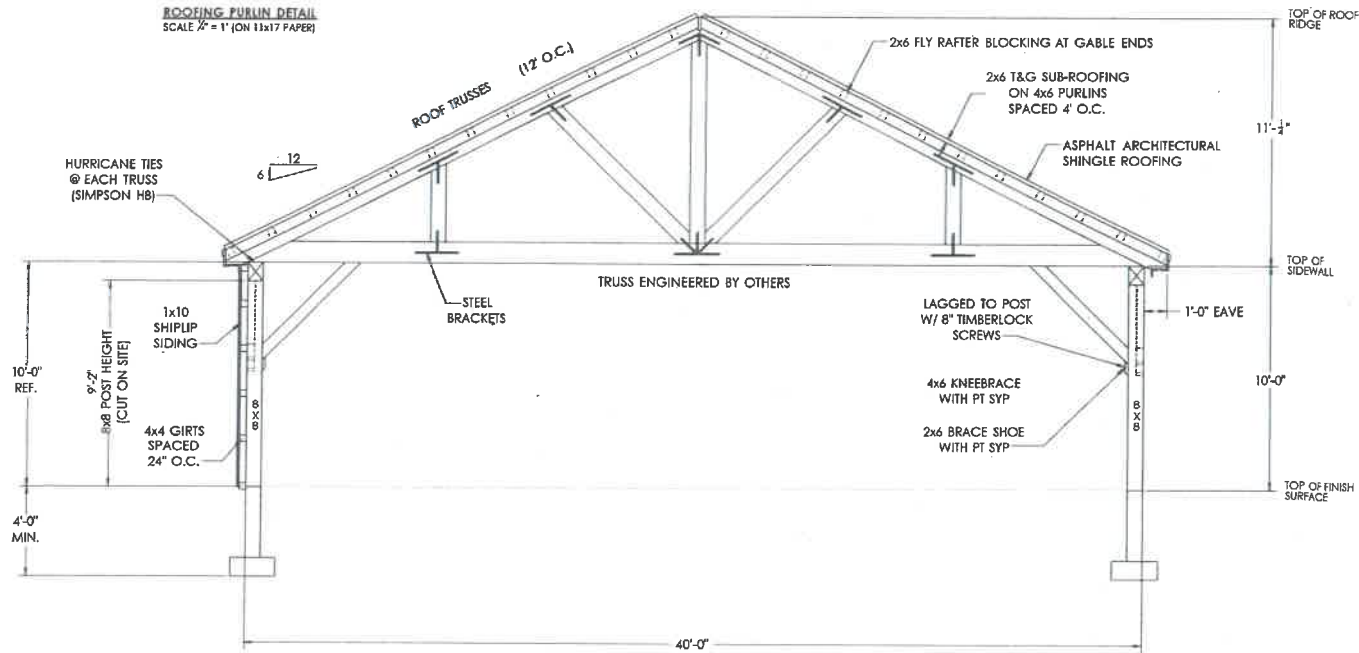

FRONT GABLE BUILDING SECTION
SCALE 1/4" = 1" (ON 11x17 PAPER)

NOTE:
• 16d NAILS USED IN ALL FRAMING CONSTRUCTION

Circle B Barn Co.

- Equine Facility Specialists -
489 Neck Road
Lancaster, Massachusetts 01553
tel. (978) 368-6400
fax (978) 368-9130
www.circleb.com

ENGINEER DISCLAIMER
THE ENGINEER'S STAMP ON THIS DRAWING QUALIFIES THE STRUCTURAL DESIGN ONLY AND ASSUMES THAT THE FOUNDATION FOOTING BEARING SURFACE IS UNDISTURBED, OR PROPERLY COMPACTED, NON-ORGANIC SOIL WITH A MINIMUM BEARING ALLOWABLE OF 2000 PSF AND THAT ALL CONSTRUCTION WILL BE PERFORMED BY QUALIFIED CRAFTSMEN IN ACCORDANCE WITH THE 8th EDITION OF THE MASSACHUSETTS BUILDING CODE. ON-SITE VERIFICATION OF CONSTRUCTION IS REQUIRED BY A QUALIFIED AGENT DURING DEMOLITION AND CONSTRUCTION TO VERIFY ASSUMPTIONS ARE CORRECT AND THAT CONSTRUCTION IS PROPERLY PERFORMED. IT IS THE CONTRACTOR'S OR OWNER'S RESPONSIBILITY TO ASSURE THAT TIMELY NOTIFICATION OF THE PROJECT PROGRESS IS PROVIDED SO THAT ADEQUATE PRESENCE OF QUALIFIED AGENT IS OBTAINED.

DATE	BY	REVISION
07/20/2024	B	REVISED CONSTRUCTION LIST

PROPRIETARY NOTICE
THIS DRAWING SHEET AND CONTENTS HEREIN ARE THE PROPERTY OF CIRCLE B. USE OF THE DRAWING'S CONTENTS FOR DESIGN CONCEPTS FOR PURPOSES OTHER THAN ESTIMATING, DRAWING PREPARATION, AND/OR MANUFACTURING FOR CIRCLE B SHALL BE CAUSE FOR LEGAL RECOURSE BY CIRCLE B BARN CO INC.

Jennifer Verrill
One Wheeler Road
Concord, MA 01742

GABLE END DETAIL

JOB #	XXXX / XXXX
DATE	7/21/2024

SHEET 7 OF 9

ENGINEER DISCLAIMER
 THE ENGINEER'S STAMP ON THIS DRAWING
 QUALIFIES THE STRUCTURAL DESIGN ONLY
 AND ASSUMES THAT THE FOUNDATION
 FOOTING BEARING SURFACE IS
 UNDEVELOPED, OR PROPERLY COMPACTED,
 NON-ORGANIC SOIL WITH A MINIMUM
 BEARING ALLOWABLE OF 2000 PSF AND
 THAT ALL CONSTRUCTION WILL BE
 PERFORMED BY QUALIFIED CRAFTSMEN
 IN ACCORDANCE WITH THE 8TH EDITION OF
 THE MASSACHUSETTS BUILDING CODE. ON-
 SITE VERIFICATION OF CONSTRUCTION IS
 REQUIRED BY A QUALIFIED AGENT DURING
 DEMOLITION AND CONSTRUCTION TO
 VERIFY ASSUMPTIONS ARE CORRECT AND
 THAT CONSTRUCTION IS PROPERLY
 PERFORMED. IT IS THE CONTRACTOR'S OR
 OWNER'S RESPONSIBILITY TO ASSURE THAT
 TIMELY NOTIFICATION OF THE PROJECT
 PROGRESS IS PROVIDED SO THAT
 ABSOLUTE PRESENCE OF QUALIFIED AGENT
 IS MAINTAINED.

REV #	DATE	DESCRIPTION
1	7/21/2024	REVISED CONSTRUCTION SET

PROPRIETARY NOTICE
 THIS DRAWING SHEET AND CONTENTS
 HEREIN ARE THE PROPERTY OF CIRCLE B
 USE OF THIS DRAWING'S CONTENT OR
 DESIGN CONCEPTS FOR PURPOSES OTHER
 THAN ESTIMATING, DRAWING
 PREPARATION, AND/OR MANUFACTURING
 FOR CIRCLE B SHALL BE CAUSE FOR LEGAL
 RECOURSE BY CIRCLE B BARN CO INC.

Jennifer Verrill
 One Wheeler Road
 Concord, MA 01474

DATE	7/21/2024
SCALE	XXXX / XXXX
PROJECT	7/21/2024

SHEET 8 OF 9

ROOF TRUSSES (SPACED 12' O.C. OVER POSTS), ENGINEERED BY OTHERS

1'-0" PRE-ASSEMBLED
 "FLY RAFTERS" @ GABLE
 (TYPICAL)

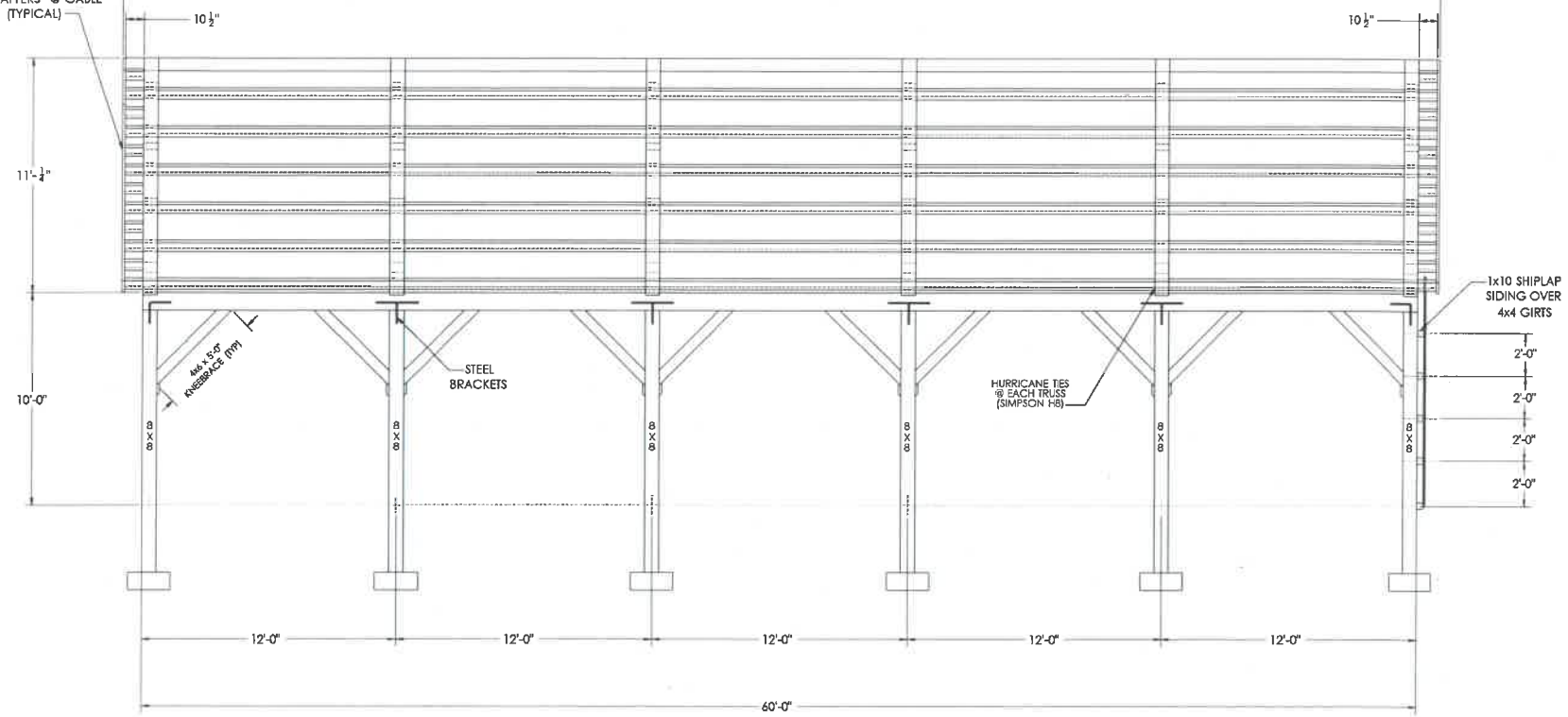

NOTE:
 * 16d NAILS USED IN ALL FRAMING CONSTRUCTION

SIDE WALL BUILDING SECTION
 SCALE: 1/4" = 1'-0" (ON 11X17 PAPER)

ENGINEER'S DISCLAIMER
THE ENGINEER'S STAMP ON THIS DRAWING QUALIFIES THE STRUCTURAL DESIGN ONLY AND ASSUMES THAT THE FOUNDATION FOOTING BEARING SURFACE IS UNDISTURBED, OR PROPERLY COMPACTED, NON-ORGANIC SOIL WITH A MINIMUM BEARING ALLOWABLE OF 2000 P/SF AND THAT ALL CONSTRUCTION WILL BE PERFORMED BY QUALIFIED CRAFTSMEN IN ACCORDANCE WITH THE 8TH EDITION OF THE MASSACHUSETTS BUILDING CODE. ON-SITE VERIFICATION OF CONSTRUCTION IS REQUIRED BY A QUALIFIED AGENT DURING CONSTRUCTION AND CONSTRUCTION TO VERIFY ASSUMPTIONS ARE CORRECT AND THAT CONSTRUCTION IS PROPERLY PERFORMED. IT IS THE CONTRACTOR'S OR OWNER'S RESPONSIBILITY TO ASSURE THAT TIMELY NOTIFICATION OF THE PROJECT PROGRESS IS PROVIDED SO THAT ADEQUATE PRESENCE OF QUALIFIED AGENT IS OBTAINED.

REV #	REVISION	DATE
1	REVISED CONSTRUCTION SET	6/10/2024

PROPRIETARY NOTICE
THIS DRAWING SHEET AND CONTENTS HEREIN ARE THE PROPERTY OF CIRCLE B. USE OF THIS DRAWING'S CONTENT OR DESIGN CONCEPTS FOR PURPOSES OTHER THAN ESTIMATING, DRAWING PREPARATION, AND/OR MANUFACTURING FOR CIRCLE B SHALL BE CAUSE FOR LEGAL RECOURSE BY CIRCLE B BARN CO INC.

Jennifer Verrell
One Wheeler Road
Concord, MA 01742

DATE: 7/21/2024

SHEET 9 OF 9

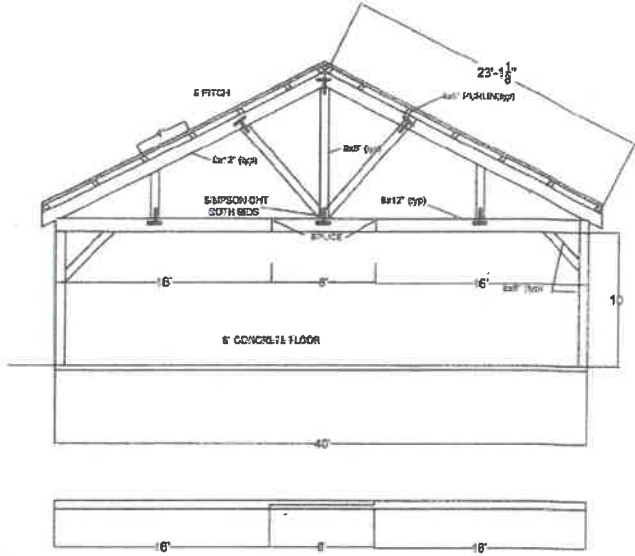
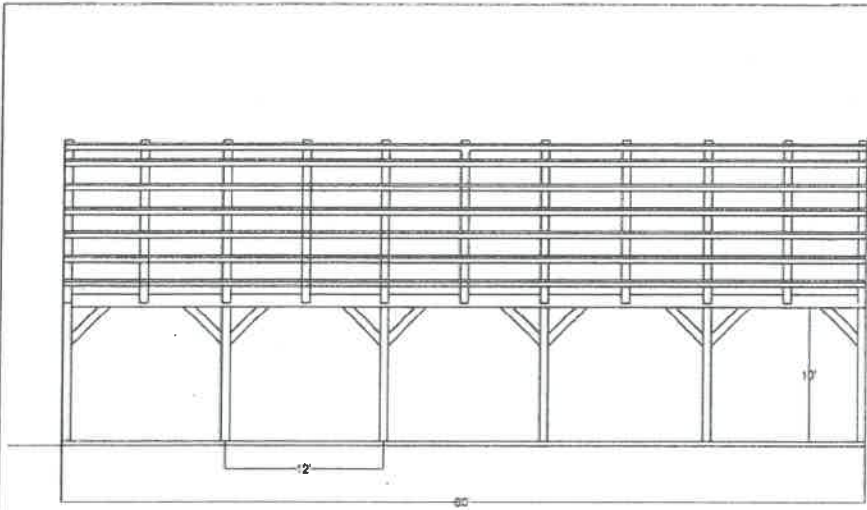

NOTE ALL WOOD TO BE HEMLOCK-FIR



PREPARED FOR
THOMAS BROWNELL
LANCASTER, MASSACHUSETTS

POLE BUILDING

CHARLES E. MICHAUD P. E.
54 ROCKY ROAD
WHITINSVILLE, MA 01588
PHONE: (508) 756-4344

DATE: 6/10/2024
JOB: 24-0516
SCALE: 1/8" = 1'-0"

PAGE: 1

THE COMMONWEALTH OF MASSACHUSETTS

EXECUTIVE OFFICE OF ENERGY AND ENVIRONMENTAL AFFAIRS



Department of Agricultural Resources

100 Cambridge Street, 9th Floor, Boston, MA 02114
www.mass.gov/agr



Maura T. Healey
GOVERNOR

Kimberley Driscoll
LIEUTENANT
GOVERNOR

Rebecca L. Tepper
SECRETARY

Ashley E. Randle
COMMISSIONER

Co-Holder Approval Form for Department Approvals

(To be completed by landowner of Agricultural Preservation Restriction [APR] or municipalities that co-hold an APR)

APR Landowner: Stephen and Joan Verrill

APR Address: 415 Plainfield Road

APR Recording Information: Registry - Middlesex South Registry of Deeds

15432 page 003

Co-Holding Municipality Name: Town of Concord

Request Type (circle one): Certificate of Approval/ Special Permit

APR Landowner requests to conduct the following activities on APR land as further described in the attached Department Approval application. By affixing a signature below, the municipality of

Concord hereby finds that the requested activities, as authorized by this APR General Laws Chapter 184 and 132A, are: **(Please Check Box)**

- Approved
- Approved with conditions
- Denied

Signature: _____ authorized signatory on behalf of _____

Date: _____

(Please send completed form back to APR landowner)

THE COMMONWEALTH OF MASSACHUSETTS
EXECUTIVE OFFICE OF ENERGY AND ENVIRONMENTAL AFFAIRS



Department of Agricultural Resources

251 Causeway Street, Suite 500, Boston, MA 02114
617-626-1700 fax: 617-626-1850 www.mass.gov/agr



CHARLES D. BAKER
Governor

KARYN E. POLITO
Lt. Governor

KATHLEEN A. THEOHARIDES
Secretary

JOHN LEBEAUX
Commissioner

*FAQs for Municipalities Considering Approval of a
Special Permit or Certificate of Approval on an APR*

1. Why are we being asked to sign this?

Your city/town is a Co-Holder of an Agricultural Preservation Restriction (“APR”) granted to MDAR. That means that when the Commonwealth acquired the APR, the municipality made a contribution of funds towards the purchase; this gives the municipality certain rights and responsibilities under the terms of the APR document and the APR Statute (M.G.L. c. 20, Section 23(b)). Some APR documents require approval of any Co-Holder in order for MDAR to issue a Certificate of Approval. Many APR documents, as well as the APR statute, require the approval of the Co-Holder for a Special Permit.

2. Why does the landowner need permission for this?

The APR restricts the use of the land in question for agricultural purposes and requires the landowner to seek approval from MDAR for certain structures and/or activities on the APR land. For more information about the APR program and the related Special Permits and Certificates of Approval, visit <https://www.mass.gov/service-details/agricultural-preservation-restriction-apr-program-details>.

3. Who should sign the Approval form on behalf of the city/town?

That may depend on each municipality’s rules, regulations or bylaws. In many cases, the executive branch would be the signatory (Select Board for a town or Mayor for a city). However, you should check with your municipality’s legal counsel to determine proper authority.

4. What are you asking us to approve?

The approval form should have both a copy of the application detailing the request and a copy of the APR document attached to it. If it does not, contact the landowner to request these documents.

5. On what basis are we making this decision?

First look to the APR document to determine if there are any required findings necessary in order to give approval. If none, the municipality may have previously determined criteria. In any event, your municipality’s legal counsel should be able to advise you.

THE COMMONWEALTH OF MASSACHUSETTS
EXECUTIVE OFFICE OF ENERGY AND ENVIRONMENTAL AFFAIRS



Department of Agricultural Resources

251 Causeway Street, Suite 500, Boston, MA 02114
617-626-1700 fax: 617-626-1850 www.mass.gov/agr



CHARLES D. BAKER
Governor

KARYN E. POLITO
Lt. Governor

KATHLEEN A. THEOHARIDES
Secretary

JOHN LEBEAUX
Commissioner

6. By signing this form are we giving approval under any zoning bylaw, building code or other municipal approvals?

No. The APR landowner is still required to obtain any zoning, building or other permits required under the local bylaws. The Department's Approval is conditional upon the owner obtaining any relevant municipal approvals. This approval is only the municipality's approval as the Co-Holder of the APR document.

7. Whom should we contact if we have other questions about the APR or this approval process?

Please contact MDAR. We are here to answer your questions! Please call the Stewardship Planner for your region or the APR Program Coordinator, Ron Hall at 413-726-2002 or email at Ronald.Hall@mass.gov and he will direct you to the appropriate Stewardship Planner handling the matter.



Concord Select Board Meeting
AGENDA ACTION REQUEST

Monday, September 23, 2024

6

Discuss and Vote to Approve: Bond Sale Authorization

Requested by: SB Chair

Action Sought: Approve

Proposed Motion(s)

Motion to Approve Bond Sale Authorization

Additional Information

Board Action

<i>Motion</i>	<i>Second</i>	<i>In favor</i>	<i>Opposed</i>	<i>Disposition</i>



TOWN OF CONCORD

Finance Department

22 Monument Square
P.O. Box 535
Concord, Massachusetts 01752

TO: Select Board,
Kerry Lafluer, Town Manager

FROM Anthony M. Ansaldi, Jr., Chief Financial Officer

DATE: September 20, 2024

RE: Approve Bond Sale Authorization

On September 19, 2024, the Town received competitive bids from bond underwriters for a \$39,561,000, new money bond issue with maturities ranging from 5 – 25 years.

The Town received a total of fourteen (14) bids on the Bonds. Bids were ranked by lowest True Interest Cost (TIC), with the winning bid received from KeyBanc Capital Markets. This original bid provides coupon rates of 4 and 5%, and a True Interest Cost of 3.448036%, including a premium of \$3,265,580.02. All bids are summarized as follows:

	Bidder	TIC	Premium
1	KeyBanc Capital Markets	3.448036	\$ 3,265,580.02
2	Fidelity Capital Markets	3.462159	\$ 2,944,213.01
3	Robert W. Baird & Co., Inc.	3.475517	\$ 3,000,989.35
4	UBS Financial Services Inc.	3.483018	\$ 2,852,772.91
5	J.P. Morgan Securities LLC	3.485832	\$ 2,785,024.89
6	FHN Financial Capital	3.492325	\$ 2,927,330.95
7	Wells Fargo Bank, National	3.496774	\$ 2,988,223.11
8	BNYMellon Capital Markets	3.496861	\$ 2,660,341.84
9	BofA Securities	3.498177	\$ 2,575,332.05
10	RBC Capital Markets	3.500227	\$ 3,021,814.44
11	Janney Montgomery Scott LLC	3.502519	\$ 3,026,022.64
12	Jefferies LLC	3.508918	\$ 2,684,393.53
13	Mesirow Financial, Inc.	3.517410	\$ 2,817,758.60
14	Huntington Securities, Inc.	3.517411	\$ 2,888,066.75

As is allowed within the authorization for each of the capital items included in this issue, the bond issue has been resized to account for the premium. The resized bond issue is \$36,730,000 with a resized premium of \$3,111,111.80. Of this amount, \$2,831,000 is used to resize the issue, \$280,111.80 will pay for the issuance costs.

The Bond Proceeds will be used to finance the following projects:

Project	Article	Included in 2024 Issue	Resized	Net Borrowed	Repayment Term
General Fund, Non-Exempt					
Assabet River Bluff Preservation (land acquisition)	ATM-2022	\$ 176,000	\$ 45,900	\$ 130,100	5
Heavy Equipment (replacement of 2008 GVWR)	ATM-2023	\$ 300,000		\$ 300,000	5
Road Improvements (parking lot rehab)	ATM-2023	\$ 425,000	\$ 425,000	\$ -	premium
Road Improvements (traffic signals and signage)	ATM-2023	\$ 515,000		\$ 515,000	10
Road Improvements (pavement management)	ATM-2023	\$ 2,650,000		\$ 2,650,000	10
School Building Improvements	ATM-2023	\$ 495,000		\$ 495,000	5
General Fund, Exempt					
Middle School Construction	STM-2022	\$ 35,000,000	\$ 2,360,100	\$ 32,639,900	25
Total Issue		\$ 39,561,000	\$ 2,831,000	\$ 36,730,000	

The bid from KeyBanc Capital Markets was accepted by the Treasurer on behalf of the Town, subject to approval of the Select Board. At its meeting of September 23, 2024, I will be seeking approval from the Select Board to approve the bond award and execute all required documents. The form of the motion is attached that the clerk will need to read into the record followed by a signature page that needs to be signed.

In my absence, Assistant Chief Financial Officer will be in attendance to answer questions.

VOTE OF THE SELECT BOARD

I, the Clerk of the Select Board of the Town of Concord, Massachusetts (the “Town”), certify that at a meeting of the Board held September 23, 2024, of which meeting all members of the Board were duly notified and at which a quorum was present, the following votes were unanimously passed, all of which appear upon the official record of the board in my custody:

Voted: that the sale of the \$36,730,000.00 General Obligation Municipal Purpose Loan of 2024 Bonds of the Town dated September 26, 2024 (the “Bonds”), to KeyBanc Capital Markets Inc. at the price of \$39,734,383.83 and accrued interest, if any, is hereby approved and confirmed. The Bonds shall be payable on September 15 of the years and in the principal amounts and bear interest at the respective rates, as follows:

<u>Year</u>	<u>Amount</u>	<u>Interest Rate</u>	<u>Year</u>	<u>Amount</u>	<u>Interest Rate</u>
2025	\$580,000	5.00%	2038	\$1,355,000	4.00%
2026	1,260,000	5.00	2039	1,410,000	4.00
2027	1,300,000	5.00	2040	1,470,000	4.00
2028	1,335,000	5.00	2041	1,530,000	4.00
2029	1,375,000	5.00	2042	1,590,000	4.00
2030	1,240,000	5.00	2043	1,655,000	4.00
2031	1,285,000	5.00	2044	1,725,000	4.00
2032	1,335,000	5.00	2045	1,795,000	4.00
2033	1,385,000	5.00	2046	1,870,000	4.00
2034	1,440,000	5.00	2047	1,945,000	4.00
2035	1,185,000	5.00	2048	2,025,000	4.00
2036	1,240,000	4.00	2049	2,105,000	4.00
2037	1,295,000	5.00			

Further Voted: that in connection with the marketing and sale of the Bonds, the preparation and distribution of a Notice of Sale and Preliminary Official Statement dated September 12, 2024, and a final Official Statement dated September 19, 2024 (the “Official Statement”), each in such form as may be approved by the Town Treasurer, be and hereby are ratified, confirmed, approved and adopted.

Further Voted: that the Bonds shall be subject to redemption, at the option of the Town, upon such terms and conditions as are set forth in the Official Statement.

Further Voted: that the Town Treasurer and the Select Board be, and hereby are, authorized to execute and deliver a continuing disclosure undertaking in compliance with SEC Rule 15c2-12 in such form as may be approved by bond counsel to the Town, which undertaking shall be incorporated by reference in the Bonds for the benefit of the holders of the Bonds from time to time.

Further Voted: that we authorize and direct the Town Treasurer to establish post issuance federal tax compliance procedures and continuing disclosure procedures in such

forms as the Town Treasurer and bond counsel deem sufficient, or if such procedures are currently in place, to review and update said procedures, in order to monitor and maintain the tax-exempt status of the Bonds and to comply with relevant securities laws.

Further Voted: that any certificates or documents relating to the Bonds (collectively, the “Documents”), may be executed in several counterparts, each of which shall be regarded as an original and all of which shall constitute one and the same document; delivery of an executed counterpart of a signature page to a Document by electronic mail in a “.pdf” file or by other electronic transmission shall be as effective as delivery of a manually executed counterpart signature page to such Document; and electronic signatures on any of the Documents shall be deemed original signatures for the purposes of the Documents and all matters relating thereto, having the same legal effect as original signatures.

Further Voted: that each member of the Select Board, the Town Clerk and the Town Treasurer be and hereby are, authorized to take any and all such actions, and execute and deliver such certificates, receipts or other documents as may be determined by them, or any of them, to be necessary or convenient to carry into effect the provisions of the foregoing votes.

[Remainder of page intentionally omitted; signature page follows.]

I further certify that the votes were taken at a meeting open to the public, that no vote was taken by secret ballot, that a notice stating the place, date, time and agenda for the meeting (which agenda included the adoption of the above votes) was filed with the Town Clerk and a copy thereof posted in a manner conspicuously visible to the public at all hours in or on the municipal building that the office of the Town Clerk is located or, if applicable, in accordance with an alternative method of notice prescribed or approved by the Attorney General as set forth in 940 CMR 29.03(2)(b), at least 48 hours, not including Saturdays, Sundays and legal holidays, prior to the time of the meeting and remained so posted at the time of the meeting, that no deliberations or decision in connection with the sale of the Bonds were taken in executive session, all in accordance with G.L. c.30A, §§18-25, as amended.

Dated: September 23, 2024

Clerk of the Select Board



Concord Select Board Meeting
AGENDA ACTION REQUEST

Monday, September 23, 2024

7

Common Victualler Application for Mark Pesce of the Pesce Network for a new Dunkin location at 794 Elm Street

Requested by: SB Chair

Action Sought: Approve

Proposed Motion(s)

Common Victualler Application for Mark Pesce of the Pesce Network for a new Dunkin location at 794 Elm Street

Additional Information

Board Action

<i>Motion</i>	<i>Second</i>	<i>In favor</i>	<i>Opposed</i>	<i>Disposition</i>



TOWN OF CONCORD
Office of the Town Manager
Town House
P.O. Box 535
Concord, Massachusetts 01742

To: Concord Select Board

From: Shannon McAndrew, Management Specialist

Date: September 23, 2024

Re: Common Victualler License Application – Dunkin’ at 794 Elm Street

Included in your meeting packet is a Common Victualler License application for Mark Pesce of the Pesce Network for a new Dunkin’ location at 794 Elm Street. This establishment will be filling the vacant restaurant space that was formerly Asian Gourmet restaurant. Mr. Pesce currently owns and operates three existing Dunkin’ locations in Town.

This application has been reviewed by the Building Department, Health Department, and Treasurer/Collector’s Department, and there are no adverse comments. The application is complete with payment, and the additional required information such as proof of General Liability and Workers Compensation Insurance and the State Tax Affidavit.

Please reach out to me if you have any questions.

SECTION 4 - MAILING ADDRESS

Street Number 72 Street Name JUNCTION SQUARE DR
 City Concord State MA Zip Code 01742
 Telephone 978-206-2469

SECTION 5 - BUSINESS DETAILS

Name of Business Dunkin'
 Street Number 794 Street Name Elm Street
 City CONCORD State MA Zip Code 01742
 Telephone 978-206-2469 Federal Tax No. (if applicable) : _____

SECTION 6 - MANAGER INFORMATION

Manager Name Geo Barbosa
 Street Number 72 Street Name Junction Square Drive
 City Concord State MA Zip Code 01742
 Telephone 978-206-2469 Email projects@pescenetwork.com

SECTION 7 - OTHER INFORMATION

Note: Please indicate A.M. or P.M.

Proposed Hours of Business	From	To
Monday	<u>4am</u>	<u>11pm</u>
Tuesday	<u>4am</u>	<u>11pm</u>

Proposed Hours of Business	From	To
Wednesday	<u>4am</u>	<u>11pm</u>
Thursday	<u>4am</u>	<u>11pm</u>
Friday	<u>4am</u>	<u>11pm</u>
Saturday	<u>4am</u>	<u>11pm</u>
Sunday	<u>4am</u>	<u>11pm</u>

Proposed Seating Capacity 50 - 36 interior, 14

Do you plan to have a jukebox / pinball machine etc? Yes No

Are you planning to file for an alcoholic beverage license? Yes No

STATE TAX AFFIDAVIT

STATE TAX AFFIDAVIT PDF **Please click this button to print out the required form. Once you have submitted this application please fill out the form and upload it to the checklist in the transaction panel.**

SECTION 8 - DECLARATION

I do hereby certify under the pains & penalties of perjury that the information provided above is true and correct.

Date 09/09/24



Concord Select Board Meeting
AGENDA ACTION REQUEST

Monday, September 23, 2024

8

Discuss and Vote to Approve: Change of Manager Liquor License Application for Nosh by Concord Market

Requested by: SB Chair

Action Sought: Approve

Proposed Motion(s)

Motion to Approve Change of Manager Liquor License Application for Nosh by Concord Market

Additional Information

Board Action

<i>Motion</i>	<i>Second</i>	<i>In favor</i>	<i>Opposed</i>	<i>Disposition</i>



TOWN OF CONCORD
Office of the Town Manager
Town House
P.O. Box 535
Concord, Massachusetts 01742

To: Concord Select Board

From: Shannon McAndrew, Management Specialist

Date: September 23, 2024

Re: Application for a Change of Manager for Nosh by Concord Market

Included in your meeting packet is an ABCC Liquor License application for a Change of Manager Application for Trail's End Café LLC, DBA Nosh by Concord Market. The ABCC requires that a Change of Manager be updated in their records via a formal application process. The application does *not* require a public hearing, though still requires the approval of the Select Board.

This application has also been reviewed by the Police Department and there were no adverse comments. This application is complete with payment. Please reach out with any questions.

Payment Confirmation

YOUR PAYMENT HAS PROCESSED AND THIS IS YOUR RECEIPT

Your account has been billed for the following transaction. You will receive a receipt via email and via text message.



Transaction Processed Successfully.

INVOICE #: a27af88c-8f2a-4c46-9e1c-da2f44a62703

Description	Applicant, License or Registration Number	Amount
FILING FEES-RETAIL	024400038	\$200.00
		\$200.00

Total Convenience Fee: \$5.18

Date Paid: 8/29/2024 1:31:14 PM EDT

Total Amount Paid: \$205.18

Payment On Behalf Of

License Number or Business Name:
024400038

Fee Type:
FILING FEES-RETAIL

Billing Information

First Name:
James

Last Name:
White

Address:

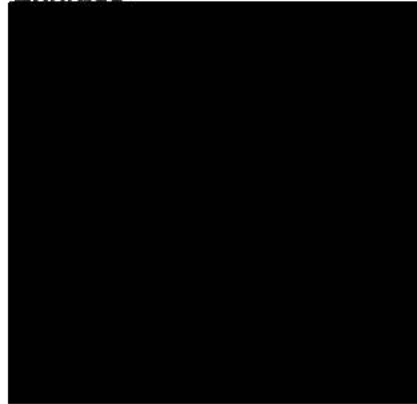

RECEIVED
AUG 29 2024

TOWN OF CONCORD
TOWN MANAGER'S OFFICE



The Commonwealth of Massachusetts
 Alcoholic Beverages Control Commission
 95 Fourth Street, Suite 3, Chelsea, MA 02150-2358
 www.mass.gov/abcc

RETAIL ALCOHOLIC BEVERAGES LICENSE APPLICATION
 MONETARY TRANSMITTAL FORM

AMENDMENT-Change of Manager

APPLICATION SHOULD BE COMPLETED ON-LINE, PRINTED, SIGNED, AND SUBMITTED TO THE LOCAL LICENSING AUTHORITY.

ECRT CODE: RETA

Please make \$200.00 payment here: [ABCC PAYMENT WEBSITE](#)

PAYMENT MUST DENOTE THE NAME OF THE LICENSEE CORPORATION, LLC, PARTNERSHIP, OR INDIVIDUAL AND INCLUDE THE PAYMENT RECEIPT

ABCC LICENSE NUMBER (IF AN EXISTING LICENSEE, CAN BE OBTAINED FROM THE CITY)

ENTITY/ LICENSEE NAME

ADDRESS

CITY/TOWN

STATE

ZIP CODE

For the following transactions (Check all that apply):

- | | | | |
|--|---|---|---|
| <input type="checkbox"/> New License | <input type="checkbox"/> Change of Location | <input type="checkbox"/> Change of Class (i.e. Annual / Seasonal) | <input type="checkbox"/> Change Corporate Structure (i.e. Corp / LLC) |
| <input type="checkbox"/> Transfer of License | <input type="checkbox"/> Alteration of Licensed Premises | <input type="checkbox"/> Change of License Type (i.e. club / restaurant) | <input type="checkbox"/> Pledge of Collateral (i.e. License/Stock) |
| <input checked="" type="checkbox"/> Change of Manager | <input type="checkbox"/> Change Corporate Name | <input type="checkbox"/> Change of Category (i.e. All Alcohol/Wine, Malt) | <input type="checkbox"/> Management/Operating Agreement |
| <input type="checkbox"/> Change of Officers/
Directors/LLC Managers | <input type="checkbox"/> Change of Ownership Interest
(LLC Members/ LLP Partners,
Trustees) | <input type="checkbox"/> Issuance/Transfer of Stock/New Stockholder | <input type="checkbox"/> Change of Hours |
| | <input type="checkbox"/> Other <input type="text"/> | | <input type="checkbox"/> Change of DBA |

THE LOCAL LICENSING AUTHORITY MUST SUBMIT THIS APPLICATION ONCE APPROVED VIA THE ePLACE PORTAL

Alcoholic Beverages Control Commission
 95 Fourth Street, Suite 3
 Chelsea, MA 02150-2358



The Commonwealth of Massachusetts
 Alcoholic Beverages Control Commission
 95 Fourth Street, Suite 3, Chelsea, MA 02150-2358
 www.mass.gov/abcc

AMENDMENT-Change of Manager **Change of License Manager**

1. BUSINESS ENTITY INFORMATION

Entity Name	Municipality	ABCC License Number
Trail's End Cafe LLC	Concord	024400038

2. APPLICATION CONTACT

The application contact is the person who should be contacted with any questions regarding this application.

Name	Title	Email	Phone
James B. White	attorney	jimwhite@elawcorporation.com	978/771-2359

3A. MANAGER INFORMATION

The individual that has been appointed to manage and control of the licensed business and premises.

Proposed Manager Name: Keir Weinberg Date of Birth: [REDACTED] SSN: [REDACTED]

Residential Address: [REDACTED]

Email: [REDACTED] Phone: [REDACTED]

Please indicate how many hours per week you intend to be on the licensed premises: 0-10 11-20 25-35 36-40 41-50

Last-Approved License Manager: Marisa Lianne Limoli

3B. CITIZENSHIP/BACKGROUND INFORMATION

Are you a U.S. Citizen? Yes No *Manager must be U.S. citizen

If yes, attach one of the following as proof of citizenship: US Passport, Voter's Certificate, Birth Certificate or Naturalization Papers.

Have you ever been convicted of a state, federal, or military crime? Yes No

If yes, fill out the table below and attach an affidavit providing the details of any and all convictions. Attach additional pages, if necessary, utilizing the format below.

Date	Municipality	Charge	Disposition

3C. EMPLOYMENT INFORMATION

Please provide your employment history. Attach additional pages, if necessary, utilizing the format below.

Start Date	End Date	Position	Employer	Supervisor Name
May 2023	Jan 2024	Catering Sales Manager	Max Ultimate Food, Boston	Alexis Davis
Aug 2017	May 2023	Catering Manager	Restaurant Associates, Boston	Rebecca Logan

3D. PRIOR DISCIPLINARY ACTION

Have you held a beneficial or financial interest in, or been the manager of, a license to sell alcoholic beverages that was subject to disciplinary action? Yes No If yes, please fill out the table. Attach additional pages, if necessary,utilizing the format below.

Date of Action	Name of License	State	City	Reason for suspension, revocation or cancellation

I hereby swear under the pains and penalties of perjury that the information I have provided in this application is true and accurate:

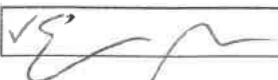
Manager's Signature:  Date: 8/27/24

APPLICANT'S STATEMENT

I, Elizabeth Akehurst-Moore the: sole proprietor; partner; corporate principal; LLC/LLP manager
Authorized Signatory
of Trall's End Cafe LLC
Name of the Entity/Corporation

hereby submit this application (hereinafter the "Application"), to the local licensing authority (the "LLA") and the Alcoholic Beverages Control Commission (the "ABCC" and together with the LLA collectively the "Licensing Authorities") for approval.

I do hereby declare under the pains and penalties of perjury that I have personal knowledge of the information submitted in the Application, and as such affirm that all statements and representations therein are true to the best of my knowledge and belief. I further submit the following to be true and accurate:

- (1) I understand that each representation in this Application is material to the Licensing Authorities' decision on the Application and that the Licensing Authorities will rely on each and every answer in the Application and accompanying documents in reaching its decision;
- (2) I state that the location and description of the proposed licensed premises are in compliance with state and local laws and regulations;
- (3) I understand that while the Application is pending, I must notify the Licensing Authorities of any change in the information submitted therein. I understand that failure to give such notice to the Licensing Authorities may result in disapproval of the Application;
- (4) I understand that upon approval of the Application, I must notify the Licensing Authorities of any change in the ownership as approved by the Licensing Authorities. I understand that failure to give such notice to the Licensing Authorities may result in sanctions including revocation of any license for which this Application is submitted;
- (5) I understand that the licensee will be bound by the statements and representations made in the Application, including, but not limited to the identity of persons with an ownership or financial interest in the license;
- (6) I understand that all statements and representations made become conditions of the license;
- (7) I understand that any physical alterations to or changes to the size of the area used for the sale, delivery, storage, or consumption of alcoholic beverages, must be reported to the Licensing Authorities and may require the prior approval of the Licensing Authorities;
- (8) I understand that the licensee's failure to operate the licensed premises in accordance with the statements and representations made in the Application may result in sanctions, including the revocation of any license for which the Application was submitted; and
- (9) I understand that any false statement or misrepresentation will constitute cause for disapproval of the Application or sanctions including revocation of any license for which this Application is submitted.
- (10) I confirm that the applicant corporation and each individual listed in the ownership section of the application is in good standing with the Massachusetts Department of Revenue and has complied with all laws of the Commonwealth relating to taxes, reporting of employees and contractors, and withholding and remitting of child support.

✓ Signature: 

Date: 8/29/24

Title: manager



Commonwealth of Massachusetts
 Alcoholic Beverages Control Commission
 239 Causeway Street, First Floor
 Boston, MA 02114

DEBORAH B. GOLDBERG
 TREASURER AND RECEIVER GENERAL

CORI REQUEST FORM

JEAN M. LORIZIO, ESQ.
 CHAIRMAN

The Alcoholic Beverages Control Commission ("ABCC") has been certified by the Criminal History Systems Board to access conviction and pending Criminal Offender Record Information ("CORI"). For the purpose of approving each shareholder, owner, licensee or applicant for an alcoholic beverages license, I understand that a criminal record check will be conducted on me, pursuant to the above. The information below is correct to the best of my knowledge.

ABCC LICENSE INFORMATION

ABCC NUMBER: 02A100038 LICENSEE NAME: Troll's End Cafe LLC CITY/TOWN: Concord
(IF EXISTING LICENSEE)

APPLICANT INFORMATION

LAST NAME: Weinberg FIRST NAME: Keir MIDDLE NAME:
 MAIDEN NAME OR ALIAS (IF APPLICABLE): PLACE OF BIRTH: [REDACTED]
 DATE OF BIRTH: [REDACTED] SSN: [REDACTED] ID THEFT INDEX PIN (IF APPLICABLE):
 MOTHER'S MAIDEN NAME: [REDACTED] DRIVER'S LICENSE #: [REDACTED] STATE LIC. ISSUED: Massachusetts
 GENDER: FEMALE HEIGHT: [REDACTED]
 CURRENT ADDRESS: [REDACTED]
 CITY/TOWN: [REDACTED]
 FORMER ADDRESS: [REDACTED]
 CITY/TOWN: [REDACTED]

PRINT AND SIGN

PRINTED NAME: Keir Weinberg APPLICANT/EMPLOYEE SIGNATURE: [Signature]

NOTARY INFORMATION

On this 8/19/24 before me, the undersigned notary public, personally appeared Keir Weinberg
 (name of document signer), proved to me through satisfactory evidence of identification, which were Mass Driver's License
 to be the person whose name is signed on the preceding or attached document, and acknowledged to me that (he) (she) signed it voluntarily for its stated purpose.
 [Signature]
 NOTARY

 **TAMMY CHRISTELL MUNROE**
 Notary Public, Commonwealth of Massachusetts
 My Commission Expires November 10, 2028

DIVISION USE ONLY

REQUESTED BY: [REDACTED]
 SIGNATURE OF CORI AUTHORIZED EMPLOYEE

The DCJ Identify Theft Index PIN Number is to be completed by those applicants that have been issued an Identify Theft PIN Number by the DCJ. Certified agencies are required to provide all applicants the opportunity to include this information to ensure the accuracy of the CORI request process. ALL CORI request forms that include this field are required to be submitted to the DCJ via mail or by fax to (617) 660-4514.



Concord Select Board Meeting
AGENDA ACTION REQUEST

Monday, September 23, 2024

9

Update from Recreation Director on Rec Revolving Fund and Beede Enterprise Fund

Requested by: SB Chair

Action Sought: None

Proposed Motion(s)

None Anticipated

Additional Information

Board Action

<i>Motion</i>	<i>Second</i>	<i>In favor</i>	<i>Opposed</i>	<i>Disposition</i>



RECREATION PROPOSAL

BY RECREATION DIRECTOR, LEIGH JACKSON AND ASSISTANT DIRECTOR, DAVID FIMIANI, 08/27/24

PROPOSAL PURPOSE

Town of Concord/Concord Recreation is pleased to present our proposal to reinstate strategic and appropriate specific financial support for the Town of Concord General Fund by holding ourselves accountable for Concord Public Work Services, as well as parks and facilities that support Concord Recreation programming via Revolving Fund. Most notably, this proposal helps our mission of supporting and promoting community through wellness and play while being accountable for the associated cost. The “Recreation Fund” is managed through a Town bylaw, voted and approved as Article II of the Amendments to the Constitution referred to as the “Home Rule Amendment,” in 2021. Section 2 states, “The Recreation Fund will be used solely for the maintenance and support of recreation and park facilities and services of the Town, including purchase of equipment and salaries of employees.” In our opinion, it is time for the Recreation Department to return to a regular fiscal indirect contribution plan.

The Problem

There are two issues that this Proposal hopes to address:

- 1) Cost of Service transfer to CPW Independently & General Fund “Indirects.”
- 2) Proposal to draw down the Recreation Fund to more appropriate levels.

Problem #1

Since the COVID pandemic, the Concord Recreation Revolving Fund has been in recovery mode. We shut down programming during the COVID–19 pandemic, due to the Governor’s orders, which financially devastated us and many recreational municipal programs across the

Commonwealth. Some of the state's municipal recreation programs operate on a Revolving Fund, 100% of program operation is covered by fees and not tax supported. We are one of those programs. During the pandemic, programs were put on hold, therefore cash receipts toward the revolving fund were minimal. Programs started back up slowly in 2019, and receipts were fully utilized on the basic program staff and supplies. Through FY20-23 recreation programming was able to get back to 'normal.' The town has been subsidizing various costs until we could get back on even ground financially. Though we are grateful for the General Fund's support on the cost of service and Recreation Department construction projects during the recovery phase, we are now in a place where the Revolving Fund is healthy and ready to charge off maintenance costs covered by the General Fund, such as: lining fields and maintaining courts. The CPW department has been our keystone partner in town for decades. We propose that in the future (as in the past) the Recreation Department cover the full cost of CPW services that support recreation programming. We make the below proposal to fix the issue of not fully paying for the services of the CPW department.

Scope of service (for CPW charge-off):

The Recreation Fund has been paying "indirect" costs back to the General Fund for years, but we haven't been paying for 100% of cost of service to CPW, this proposal addresses that. The agreed-upon scope is maintenance for all facilities. The agreed-upon facilities are Emerson Field, Emerson Infield Skins, White Pond, Ride Out "General", Ride Out Field, and Hunt Side Lawn.

Timing of interdepartmental transfer:

The agreed-upon plan is to process the final charge-off at the end of the fiscal year.

The Proposed Solution

Solution to Problem #1

The Recreation Division within Town Services will coordinate with the Town of Concord CPW department to plan seasonal work, and the CPW will execute in-house services where they have the capacity and time, otherwise, they will contract the services and charge off the expense to the Recreation Department. Quarterly estimates will be delivered to the Recreation Department from CPW (to account for any unexpected needs). Recreation will use the estimates to plan effectively for the annual transfer. The Recreation Department will process an interdepartmental yearly transfer using GL 11630000 -5199 that covers the cost maintenance service. If either party is unsatisfied at the service level, they will promptly present concerns to the other department and work together toward resolution.

At the end of each year, the full “cost of service” will be paid through interdepartmental transfer from the Recreation Fund to CPW’s General Fund at the end of the fiscal year. The Recreation Department, CPW, and other interested parties have agreed that the Cost of Service for FY25 will be \$99,000.00*. This figure covers maintenance and support facilities that we utilize for our programs. We deem this figure sustainable over time.

The Recreation Department will also continue to transfer funds back to the General Fund for the *indirect costs* of supporting the Recreation Department Services (formula determined by the Finance Department with the support of the Town Manager). The agreed-upon indirect expense for FY25 is \$136,000.00. The Indirect cost formula may change for FY26.

**A similar strategy will be used for the Enterprise Fund/Beede Swim and Fitness Center for any related support by CPW to be implemented in FY25 and FY26 determined and agreed upon before the FY26 Budget goes to the Town Meeting through the same process as the Recreation Revolving Fund.

Problem #2

The Recreation Fund has a healthy fund balance, of approximately 2 million. The Fund balance has been a concern of state auditors and therefore the Town of Concord. Town leadership has asked Recreation to consider the issue and propose a solution. There are solutions presented herein.

SCOPE AND COST OF STANDARD SERVICES

The below Scope of Service outlines the services we expect to take place, year to year. There could be additional “unplanned” CPW services needed, that are not listed in this proposal. This is simply the “planned” proposal. Any additional services will be agreed upon by the Recreation Department before action by CPW to implement the project and before charge-off.

The Recreation Department Proposal takes responsibility for all associated maintenance/facility fees associated with cash receipts for recreation programming. We propose that open space/unprogrammed playground, and school groups maintenance costs get paid through the General Fund or Schools. Each year, the service fee will be re-assessed based on the prior year's cost of service. This process will take place within the Fiscal Budget schedule so that fees can be determined agreed upon and included in the budget.

Concord Recreation Proposal for FY25 Cost of Service Charge-Off *

					
			Labor Cost		Material Cost Total Maintenance Cost
Emerson Field			\$13,629.84		
Emerson Infield Skins			\$15,206.08	\$4,500.00	\$19,706.08
White's Pond			\$20,500.32		
Rideout General			\$18,149.94	\$3,660.00	\$21,809.94
Rideout Fields			\$12,239.04		
Hunt Side Lawn			\$11,775.44		
Totals			\$91,500.66	\$8,160.00	\$99,660.66

*See attached 1) Recreation proposal for details 2) CPW cost of maintenance spreadsheet for local assets in Concord

**Enterprise charge-off for cost of service is not included in the chart above. The Enterprise Charge off will be determined in FY25 using the same process as we used for the Recreation Revolving Fund.

Solution to Problem #2

For several years, the Finance Department and the Select Board office have been concerned about the balance of the Revolving Fund. It is important to note, that there was some public discussion that perhaps the Recreation Department should lower their fees to ensure that the Revolving Fund did not grow from year to year. The Recreation Department wants to go on record to say that we feel strongly that reducing fees is not the way to ensure spending throughout the year, instead, we present other more advantageous solutions to our overall financial health and sustainability.

The Revolving Fund balance should be closer to one million dollars, which would be utilized for unexpected expenses stemming from an emergency, such as COVID-19 government-issued program shutdowns presented in 2019. Like other Massachusetts Municipalities, the Concord Recreation Fund (retained) should be considered for select smaller capital projects that support recreation programs, park maintenance, and services. This would help drawing down retained earnings, serve the needs of the Recreation Department programs, and appropriately act as a relief to the General Fund.

Therefore, the Recreation Department formally proposes that the Town consider using the Recreation Fund (retained earnings) for specific related capital improvement projects. We have

recently identified capital needs for FY26 and have a fitting project. The Recreation Capital project that we plan to propose is from the 2022 Town of Concord Recreation Facilities Master Plan (Weston and Sampson), Phase II Expansion “Feasibility” at Hunt Recreation. Hunt Recreation is not designed efficiently or effectively for our current program needs, much less the future. As we are envisioning a Hunt for the next 15-20 years. We have a need for additional gym space in town, as well as multi-purpose space, and a re-design the internal concept. This CIP Project is a perfect candidate for the Recreation Revolving Fund. We think there are likely more projects in the future that would be ideal for the Recreation Revolving Fund.

As each fiscal year approaches, and projects are needed, we will consider the Recreation Fund (retained earnings) to support capital projects that support the Recreation Department Services. We will work closely with the Recreation Commission, Town Manager, and Facilities Department to continue to assess each fiscal year whether a future project should be coming from the Revolving Fund retained earnings. The current process is a proposal from the Department that will go to the Recreation Commission for a vote. The Recreation Commission would vote “yes” or “no” for the project to be funded, what fiscal year the project would hit the budget, and what fund should be used (Recreation Fund -retained earnings or a request for General Fund Support). Their vote would be shared with The Assistant Town Manager, the Finance Department, and the Town Manager for their review and consideration. The Town Manager or his/her designee would decide whether the project gets approved for the Town Meeting CIP Warrant (if General Fund request), and to what budget it would be assigned.

We recently prioritized our Capital Projects for several reasons, but the Capital Outlay Plan below shows how we will draw down retained earnings for this year forward. Capital Plan below is positively voted by the Recreation Commission, example we’ll draw down \$242,000 in FY26; FY27 and additional \$110,000; FY28 an additional \$500,000.00 will be utilized for Emerson Courts, and so on.

Revolving Fund - Retained	Previous Years	FY26	FY27	FY28	FY29	FY30	Future Years
Emerson Pool - Gunite Replacement & Tiling		\$110,000.00					
Hunt - Phase 2 - Re-design and Addition Feasibility		\$100,000.00					
Rideout Tennis Courts -Repair/Replacement*FundedFY23*	\$130,000.00						
Rideout Basket Ball Courts - Repair		\$42,000/\$350,000					
Emerson Tennis Courts - Full Replacement							\$336,000.00
2 Emerson Basketball Courts - Full Replacement			\$60,000.00	\$500,000.00			
Emerson Quarter - Mile Track - Full Replacement							\$560,000.00
<i>Hunt - Phase 2 Expansion</i>							
Gerow Park Maintenance Contribution			\$50,000.00				\$1,000,000.00
White Pond							
CPC Consideration							
Gerow Park - Phase 2 Design and Feasibility		\$90,000.00					
Gerow Park - Phase 2 Construction			\$250,000.00				

CONCLUSION

In conclusion, Concord Recreation is a proud partner with the Town of Concord's Public Works Department, working together and supporting our goal to serve the community at the highest standard. Through this proposal, we set a course to standardize our financial support for the cost of service across the departments. Though the scope of service sets us on a better track for financial accountability, we recommend that the scope and cost of service get assessed annually through the budget cycle. This will allow a comprehensive and fair approach to assigning costs in line with charge-offs consistent with other Revolving and Enterprise Funds.

Furthermore, the Recreation Department plans to formalize its financial sustainability by moving to a formal financial sustainability model. The first step in this process will likely take place in FY25 with formal cost recovery training and analysis. We'd be working with an outside consultant in late 2025 and hope to begin implementation in FY26. This will give us confidence that we have a sustainable model that we can rely on for years to come.

Recreation Revolving Fund & Beede Enterprise

Select Board Update

9/23/24



FY2024 Revolving Fund Activity

FY2024	<u>Total Recreation Fund</u>
Beginning Fund Balance	\$2,283,416.33
FY24 Revenue Activity	\$2,381,930.45
FY24 Expense Activity	<u>(\$2,576,905.20)</u>
(unaudited) Ending Fund Balance	<u>\$2,088,441.58</u>

Recreation Fund FY2025 – Capital Outlay Plan

Revolving Fund - Retained	Previous Years	FY25	FY26	FY27	FY28	FY29	FY30	Future Years
Emerson Pool - Gunite Replacement & Tiling		\$110,000						
Hunt - Phase 2 - Re-design and Addition Feasibility			100,000					
Rideout Tennis Courts -Repair/Replacement*FundedFY23*	\$130,000							
Rideout Basketball Courts - Repair			\$42,000/ \$350,000					
Emerson Tennis Courts - Full Replacement								\$336,000
2 Emerson Basketball Courts - Full Replacement				\$60,000	\$500,000			
Emerson Quarter - Mile Track - Full Replacement								\$560,000
<i>Hunt - Phase 2 Expansion</i>								\$1,000,000
Gerow Park Maintenance Contribution				\$50,000				
White Pond								

FY2025 – and On-going Transfer to CPW Proposal - Master

	Labor Cost	Material Cost	Total Maintenance Cost
Emerson Field	\$13,629.84		
Emerson Infield Skins	\$15,206.08	\$4,500.00	\$19,706.08
White's Pond	\$20,500.32		
Rideout General	\$18,149.94	\$3,660.00	\$21,809.94
Rideout Fields	\$12,239.04		
Hunt Side Lawn	\$11,775.44		
Totals	\$91,500.66	\$8,160.00	\$99,660.66

FY2024 Beede Enterprise Fund Activity

FY2024	<u>Beede</u>
Beginning Fund Balance	\$4,359,141.22
FY24 Revenue Activity	\$2,480,374.22
FY24 Expense Activity	<u>(\$2,170,557.52)</u>
(unaudited) Ending Fund Balance	<u>\$4,668,957.92</u>

Beede Enterprise Fund FY2025 – Capital Outlay Plan

Enterprise Fund - Beede Swim and Fitness	FY25	FY26	FY27	FY28	FY29	FY30
Repair Roof - Excessive Leaking		\$711,000.00				
Full Replacement						
Structural Wall Work		\$500,000.00				
Painting and Repair Inside Pool Area		\$750,000.00				
UV Light System Lap	\$38,000.00					
CO2 Monitor System	\$55,000.00					
<i>Elevator (TBD)</i>						
Building Improvements	\$30,000.00	\$50,00.00	\$160,000.00	\$50,000.00	\$30,000.00	\$40,000.00
Natatorium Improvements	\$55,000.00	\$173,000.00	\$83,000.00	\$129,000.00	\$129,000.00	\$83,000.00
Fitness Equipment (Cardio and Strength)		\$80,000.00		\$55,000.00	\$10,000.00	\$20,000.00
	\$178,000.00	\$2,214,000.00	\$243,000.00	\$234,000.00	\$169,000.00	\$143,000.00

			Labor Cost		Material Cost	Total Maintenance Cost
Cushing Middle School Field			\$15,852.10		\$3,339.00	\$19,191.10
Rideout Fields			\$21,415.30		\$9,991.50	\$31,406.80
Rideout General			\$18,149.94		\$3,660.00	\$21,809.94
Ripley Soccer field			\$13,858.62		\$8,354.40	\$22,213.02
Ripley Baseball			\$21,229.86		\$4,175.00	\$25,404.86
Emerson Field			\$47,124.94		\$16,883.00	\$64,007.94
Emerson Infield Skins			\$15,206.08		\$4,500.00	\$19,706.08
Upper Sanborn School Field			\$26,399.22		\$10,978.00	\$37,377.22
White's Pond			\$19,100.32		\$1,400.00	\$20,500.32
						\$261,617.28
Totals			\$198,336.38		\$63,280.90	\$261,617.28

			Labor Cost		Material Cost	Total Maintenance Cost
Emerson Field			\$13,629.84			
Emerson Infield Skins			\$15,206.08		\$4,500.00	\$19,706.08
White's Pond			\$20,500.32			
Rideout General			\$18,149.94		\$3,660.00	\$21,809.94
Rideout Fields			\$12,239.04			
Hunt Side Lawn			\$11,775.44			
Totals			\$91,500.66		\$8,160.00	\$99,660.66

Revolving Fund - Retained	Previous Years	FY26	FY27	FY28	FY29	FY30	Future Years
Emerson Pool - Gunite Replacement & Tiling		\$110,000.00					
Hunt - Phase 2 - Re-design and Addition Feasibility		\$100,000.00					
Rideout Tennis Courts -Repair/Replacement*FundedFY23*	\$130,000.00						
Rideout Basket Ball Courts - Repair		\$42,000/\$350,000					
Emerson Tennis Courts - Full Replacement							\$336,000.00
2 Emerson Basketball Courts - Full Replacement			\$60,000.00	\$500,000.00			
Emerson Quarter - Mile Track - Full Replacement							\$560,000.00
<i>Hunt - Phase 2 Expansion</i>							
Gerow Park Maintenance Contribution			\$50,000.00				\$1,000,000.00
White Pond							
CPC Consideration							
Gerow Park - Phase 2 Design and Feasibility		\$90,000.00					
Gerow Park - Phase 2 Construction			\$250,000.00				

Notes: CPW has \$130,000 plus in previously approved General Funds

Enterprise Fund - Beede Swim and Fitness	FY25	FY26	FY27	FY28	FY29	FY30	Future Years
Repair Roof - Excessive Leaking	\$400,000	\$711,000					
Full Replacement							
Structural Wall Work		\$ 500,000.00					
Painting and Repair Inside Pool Area		\$ 750,000.00					
UV Light System Lap	\$38,000						
CO2 Monitor System	\$55,000						
Elevator ???							
Building Improvements	\$30,000	\$50,00.00	\$160,000.00	50,000	\$30,000	\$40,000.00	
Natatorium Improvements	\$55,000	\$173,000.00	\$83,000.00	129,000	\$129,000	\$83,000.00	
Fitness Equipment (Cardio and Strength)		\$80,000.00		55,000	\$10,000	\$20,000.00	
	\$178,000	\$2,214,000	\$ 243,000.00	\$234,000.00	\$ 169,000.00	\$ 143,000.00	

still waiting on numbers

FY25 Notes : push 400K to FY26 for roof restoaration.

Buildling Improvements: Wall repair, parking lot cameras, VFD for air handler

Natarium Improvement: Pumps, motors, valves, plumbing, light management sytem

FY26 Notes :

Building Improvements: ADA doors, locker handles, 20K unplanned.

Natatorium Improvements: Pumps, motors, plumbing, deck equipment, diving board, 2 Butterfly valves (Dive Well 25K each)

FY27 Notes:

Building improvements: ADA doors, parking lot improvements,carpets 30K,interior painting 40K, unplanned building needs

Natatorium Improvements:Pumps, motors, plumbing,diving board replacement, unplanned.

FY28 Notes:

Building Improvements: ADA doors, locker room mirrors, unplanned

Natatorium Improvements: Childrens pool pump and motors, valves, plumbing, pool lifts, diving board, unplanned

FY29 Notes:

Building Improvements: ADA doors, unplanned

Natatorium Improvements: Water heaters, valves, plumbing, diving board, pool ladders, unplanned

FY30 Notes:

Building Improvements: ADA doors, wall repairs, unplanned.

Natatorium Notes: Filter Sand replacement, diving board, unplanned



Concord Select Board Meeting
AGENDA ACTION REQUEST

Monday, September 23, 2024

10

Discuss and Vote to Approve: APP#16 Flag Raising Policy

Requested by: SB Chair

Action Sought: Approve

Proposed Motion(s)

Move to Approve: APP#16 Flag Raising Policy

Additional Information

Board Action

<i>Motion</i>	<i>Second</i>	<i>In favor</i>	<i>Opposed</i>	<i>Disposition</i>

Amended by Vote of SB: 12/13/93

Revised: 06/99

Revised: 06/05/23

Revised:

09/XX/2024

Town of Concord

APP # 16

Flag Raising Policy

1. Purpose

This policy establishes guidelines for flying flags on Town property, specifically (1) the flags of the United States of America, the Commonwealth of Massachusetts, the Town of Concord, and branches of the U.S. Military (“Federal, State and Local Flags”); (2) the flags of the United Nations and Sister Cities (“International Flags”); and (3) flags for parades, holidays, and celebrations (“Ceremonial Flags”).

In adopting this policy, the Select Board declares that flagpoles owned or maintained by the Town of Concord are not intended to and do not serve as a forum for free expression by the public, but rather as a forum for the display of governmental and nongovernmental flags authorized by the Select Board, either as required by law or as an expression of the Town’s official governmental speech and policy sentiments.

2. Policy

Flags exhibited from Town-owned property shall be displayed in conformance with "Our Flag" <https://www.govinfo.gov/content/pkg/CDOC-108hdoc97/pdf/CDOC-108hdoc97.pdf>

Federal, State and Local Flags

1. The Town, at the Town Manager’s discretion, may fly the following flags daily on permanent Town flag poles: the American flag, the Commonwealth of Massachusetts flag, official flags of the U.S. Military, the Town of Concord flag and the POW/MIA flag.
2. The Town, at the Town Manager’s discretion, may fly American flags on flag holders attached to Town light poles or other temporary poles during federal and state holidays, Flag Day and Concord’s Birthday.
3. Only the American flag in the center of Town shall be lowered to half mast, unless otherwise determined by the Town Manager (see Flag Raising and Lowering section below).

International Flags

1. The Town, at the Town Manager’s discretion, may fly the United Nation’s flags on temporary poles annually on United Nations Day and Peace Day
2. The Town, at the Town Manager’s discretion, may fly Concord Sister City

flags on Concord Townhouse railings and/or temporary poles during related visitations and events.

Ceremonial Flags

As an expression of the Town's official government speech, the Select Board may authorize the display of a Ceremonial Flag below the American flag on the Town center flagpole. The Town may fly Ceremonial Flags and authorize flag raising events to commemorate nationally recognized celebrations, days of observance, or other events which reflect the Town's official sentiment, as determined by the Select Board.

1. The Select Board shall consider the display of a Ceremonial Flag only when the request is sponsored by a Select Board member and is associated with a town celebration or proclamation. The Select board will confirm approval by a formal vote at a scheduled public meeting.
2. Ceremonial Flags are intended to be flown for one day. Same day removal will be subject to availability of staff resources and equipment. The Ceremonial Flag must be no larger in any dimension than the American flag flown above it. The flag shall only be raised and lowered by the Fire Department in accordance with this policy.
3. A Ceremonial Flag, or funding for such purchase, may be donated to the Town, or purchased at the Town's expense with Town Manager approval, subject to the availability of funds, and subject to all applicable laws regarding donations and appropriations. The Town Manager shall ensure that ceremonial flags are made available 48 hours before the scheduled flag raising. The Town shall own all such flags.
4. **[The Town, with the approval of the Town Manager [Select Board], may fly [#] Ceremonial flags on flag holders attached to Town light poles in conjunction with an authorized flag on the Town center flagpole.]**
5. Any request to display a flag shall be made in writing by a Select Board member at least 30 days in advance of the requested date for flying a flag. Requests should be forwarded to the Town Manager and presented to the Select Board by the Town Manager. Requests include the following information:
 - a) Requested date for display of the flag
 - b) Explanation or purpose of the request, including any local, national or international affiliation, and brief history including, where appropriate, links to relevant websites or organizations explaining the history of the flag.
 - c) Whether the requesting Select Board member intends to hold a flag-raising ceremony
 - d) The proposed source of funding for flag acquisition by the Town.

Flag Raising and Lowering

The Fire Department will be responsible for the lowering and raising of the American

flag in the center of Town, and any Ceremonial Flags on the flagpole per the policy described above.

The American flag in the center of Town shall be lowered to half-staff on any day:

1. When an elected Town official who dies during a term of office has a service or is buried in Concord;
2. When any former Select Board member has a service or is buried in Concord;
3. When any veteran or member of the armed forces has a service, or is buried, in Concord;
4. When any memorial exercises are held in Concord for any member of the armed services buried on foreign soil;
5. When any Honored Citizen has a service or is buried in Concord;
6. When any citizen with a record of significant service or contribution to the Town has a service, or is buried, in Concord;
7. On those holidays and occasions so designated by the State or Federal government;
8. On other occasions when appropriate in the determination of the Town Manager.

In addition, on days of community mourning the Town Manager may order that all flags on Town property be placed at half-staff.

Flag Procedures

1. For occasions listed under items 1 through 5 and 7 under the Flag Raising and Lowering policy statement, the Fire Department shall lower the American flag upon notification of a service or burial by a Town official, the clergy, funeral directors, or citizens-at-large.
2. For situations covered by items 6 and 8 under the Flag Raising and Lowering policy statement, the Fire Department shall lower the American flag upon notification by the Chair of the Select Board, or the Town Manager.
3. Only the American flag in the center of Town shall be lowered, unless otherwise determined by the Town Manager.
4. The Fire Department shall maintain a log of all American flag lowering. The log shall show the date, name of the individual, and how the individual qualified under the policy.

Distribution: All Department Heads
All Committee and Board Chairpersons

Amended by Vote of SB: 12/13/93

Revised: 06/99

Revised: 06/05/23

Revised:

09/XX/2024

Town of Concord

APP # 16 Flag Raising Policy

1. **Purpose**

This policy establishes guidelines for flying flags on Town property, specifically (1) the flags of the United States of America, the Commonwealth of Massachusetts, the Town of Concord, and branches of the U.S. Military ("Federal, State and Local Flags"); (2) the flags of the United Nations and Sister Cities ("International Flags"); and (3) flags for parades, holidays, and celebrations ("Ceremonial Flags").

In adopting this policy, the Select Board declares that flagpoles owned or maintained by the Town of Concord are not intended to and do not serve as a forum for free expression by the public, but rather as a ~~nonpublic~~ forum for the display of governmental and nongovernmental flags authorized by the Select Board, either as required by law or as an expression of the Town's official governmental speech and policy sentiments.

2.

Policy Flags exhibited from Town-owned property shall be displayed in conformance with ~~the Federal "Our Flag" publication of the Congress~~ <https://www.govinfo.gov/content/pkg/CDOC-108hdoc97/pdf/CDOC-108hdoc97.pdf>, ~~including but not limited to the requirement that no other flag or pennant should be placed above or, if on the same level, to the right of the flag of the United States of America, and no flag should be flown equal, above, or in a position of superior prominence or honor to, or in place of, the flag of the United States.~~

Federal, State and Local Flags

1. The Town, at the Town Manager's discretion, may fly the following flags daily on permanent Town flag poles: the American flag, the Commonwealth of Massachusetts flag, official flags of the U.S. Military, the Town of Concord flag and the POW/MIA flag.
2. The Town, at the Town Manager's discretion, may fly American flags on flag holders attached to Town light poles or other temporary poles during federal and state holidays, Flag Day and Concord's Birthday.
3. Only the American flag in the center of Town shall be lowered to half mast, unless otherwise determined by the Town Manager (see Flag Raising and Lowering section below).

International Flags

1. The Town, at the Town Manager's discretion, may fly the United Nation's flags on temporary poles annually on United Nations Day and Peace Day
2. The Town, at the Town Manager's discretion, may fly ~~the flag of~~ Concord Sister City flags on Concord Townhouse railings and/or temporary poles during related visitations and events.

Ceremonial Flags

As an expression of the Town's official government speech, the Select Board may authorize the display of a Ceremonial Flag below the American flag on the Town center flagpole. The Town may fly Ceremonial Flags and authorize flag raising events to commemorate nationally recognized celebrations, days of observance, or other events which reflect the Town's official sentiment, as determined by the Select Board.

1. The Select Board shall consider the display of a Ceremonial Flag only when the request is sponsored by a Select Board member and is associated with a town celebration or proclamation. The Select board will confirm approval by a formal vote at a scheduled public meeting.
2. Ceremonial Flags are intended to be flown only for one the day. Same day removal will be subject to availability of staff resources and equipment. The Ceremonial Flag must be no larger in any dimension than the American flag flown above it. The flag shall only be raised and lowered by the Fire Department in accordance with this policy.
3. A Ceremonial Flag, or funding for such purchase, may be donated to the Town, or purchased at the Town's expense with Town Manager approval, subject to the availability of funds, and subject to all applicable laws regarding donations and appropriations. The Town Manager shall ensure that ceremonial flags are made available 48 hours before the scheduled flag raising. The Town shall own all such flags.
4. **[The Town, with the approval of the Town Manager ~~and~~ [Select Board], may fly [#] Ceremonial flags on flag holders attached to Town light poles in conjunction with an authorized flag on the Town center flagpole.]**
5. Any request to display a flag shall be made in writing by a Select Board member at least 30 days in advance of the requested date for flying a flag. Requests should be forwarded to the Town Manager and presented to the Select Board by the Town Manager. Requests include the following information:
 - a) Requested date for display of the flag
 - b) Explanation or purpose of the request, including any local, national or international affiliation, and brief history including, where appropriate, links to relevant websites or organizations explaining the history of the flag.
 - c) Whether the requesting Select Board member intends to hold a flag-raising ceremony
 - d) The proposed source of funding for flag acquisition by the Town.

Flag Raising and Lowering

The Fire Department will be responsible for the lowering and raising of the American flag in the center of Town, and any Ceremonial Flags on the flagpole per the policy described above.

The American flag in the center of Town shall be lowered to half-staff on any day:

1. When an elected Town official who dies during a term of office has a service or is buried in Concord;
2. When any former Select Board member has a service or is buried in Concord;
3. When any veteran or member of the armed forces has a service, or is buried, in Concord;
4. When any memorial exercises are held in Concord for any member of the armed services buried on foreign soil;
5. When any Honored Citizen has a service or is buried in Concord;
6. When any citizen with a record of significant service or contribution to the Town has a service, or is buried, in Concord;
7. On those holidays and occasions so designated by the State or Federal government;
8. On other occasions when appropriate in the determination of the Town Manager.

In addition, on days of community mourning the Town Manager may order that all flags on Town property be placed at half-staff.

3. **Flag Procedures**

1. For occasions listed under items 1 through 5 and 7 under the Flag Raising and Lowering policy statement, the Fire Department shall lower the American flag upon notification of a service or burial by a Town official, the clergy, funeral directors, or citizens-at-large.
2. For situations covered by items 6 and 8 under the Flag Raising and Lowering policy statement, the Fire Department shall lower the American flag upon notification by the Chair of the Select Board, or the Town Manager.
3. Only the American flag in the center of Town shall be lowered, unless otherwise determined by the Town Manager.
4. The Fire Department shall maintain a log of all American flag lowering. The log shall show the date, name of the individual, and how the individual qualified under the policy.

Distribution: All Department Heads
All Committee and Board Chairpersons



Concord Select Board Meeting
AGENDA ACTION REQUEST

Monday, September 23, 2024

11

Discuss Town Manager's Annual Evaluation Compilation

Requested by: SB Chair

Action Sought: None

Proposed Motion(s)

None Anticipated

Additional Information

Board Action

<i>Motion</i>	<i>Second</i>	<i>In favor</i>	<i>Opposed</i>	<i>Disposition</i>



TOWN OF CONCORD
HUMAN RESOURCES DEPARTMENT
55 CHURCH STREET
CONCORD, MASSACHUSETTS 01742

TEL: 978-318-3025
FAX: 978-318-3393
hr@concordma.gov

MEMORANDUM

To: Concord Select Board

cc: Kerry A. Lafleur, Town Manager

From: Jessica Porter, Assistant Town Manager

Re: FY2024 Town Manager Annual Performance Review

On Monday evening, September 23, 2024, I will be presenting to the Select Board the composite evaluation for FY2024 for Town Manager Kerry Lafleur.

The composite evaluation included ratings and comments from current Board members Terri Ackerman, Mary Hartman and Mark Howell, as well as former Board member Henry Dane. I was unable to secure a completed review from former Board member Linda Escobedo.

Per Open Meeting Law guidelines, I am unable to provide the composite review to you in advance of Monday evening's meeting. It must be distributed to you once the meeting has been opened. I will provide paper and electronic copies of the documents to you at the start of the meeting on Monday evening. Copies have been provided to Town Manager Lafleur for her to review in advance and be prepared for any questions or discussion.

As a reminder, the Select Board, not the public, is tasked with reviewing the Town Manager. While the review must be conducted in open public meeting the Select Board should not solicit public comments at the meeting regarding Ms. Lafleur's review. The composite review documents will be available by public record request for anyone wishing to obtain a copy.

Lastly, the Select Board will need to schedule an Executive Session agenda item at the next meeting to discuss Ms. Lafleur's compensation for FY2025 in accordance with her employment contract. While the discussion and negotiation regarding her compensation may take place in Executive Session, the final determination must be made in open public session.

For future reference, Ms. Lafleur's contract contains the following provisions relative to annual increases:

B. Ms. Lafleur shall be eligible to receive a cost of living adjustment (COLA) to her annual base salary in the second and third year of this Agreement in an amount not to exceed the annual cost of living adjustment (COLA) provided to other non-union employees. Such salary adjustments shall take effect on July 1 of each fiscal year.

C. Ms. Lafleur shall be eligible to receive a merit bonus in consideration of the prior year's performance evaluation, in accordance with the provisions of Section 11. For satisfactory performance, she will earn a bonus of 3.5% of base salary. She has the opportunity to earn an additional bonus of up to 1.5% of base salary if her performance is deemed to be above satisfactory. Said merit bonus shall not be added to the following year's base salary.

Should you have any questions prior to Monday evening's meeting, please do not hesitate to reach out.



Concord Select Board Meeting
AGENDA ACTION REQUEST

Monday, September 23, 2024

12

Discuss and Accept Town Manager FY25 Goals

Requested by: SB Chair

Action Sought: Accept

Proposed Motion(s)

Discuss and Accept Town Manager FY25 Goals

Additional Information

Board Action

<i>Motion</i>	<i>Second</i>	<i>In favor</i>	<i>Opposed</i>	<i>Disposition</i>



Town of Concord
 Town Manager's Office
 22 Monument Square
 P.O. Box 535
 Concord, Massachusetts 01742-0535
 Tel: (978) 318-3000
 Fax: (978) 318-3093

To: Select Board *HAL*
 From: Kerry A. Lafleur, Town Manager
 Date: September 18, 2024
 Subject: FY25 Goals

In July 2024, the Select Board established its goals for FY25, and in earlier this month, I provided you with a draft of the Town Manager's goals. I have summarized the goal categories below, and as you can see, there is significant overlap, showing strong alignment of opportunities.

Select Board	Category	Town Manager
	Effective & Transparent Government	
	Land Use Opportunities	x
	Town Infrastructure & Planning	x
	Financial Planning & Stability	
	Diversity, Equity & Inclusion	
x	Strategic Planning	
x	Organization Resilience	

After taking into consideration both the feedback received at your meeting on September 9, 2024, and additional feedback received by individual members since that time, I am providing a revised draft which incorporates the following:

- Removed several action items which were identified as routine/ normal course of business;
- Reordered categories, moving strategic planning to the top to highlight as a significant priority; and
- Added in new action items targeting utilities, including CMLP governance.

In addition, I have added a column to identify the desired outcome of each specific action item.

I acknowledge that I chose not to duplicate Select Board goals, but instead will formally acknowledge that all the Select Board goals are equally shared by staff and all staff commit to actively engage in activities to ensure their achievement to the greatest extent possible. To that end, I have asked each department manager to open a dialogue with staff to identify the following with respect to each of the Select Board goals for FY25:

- Activities already included in current FY25 work plan in support of goals;
- Additional work to be incorporated into existing FY25 work plan in support of goals; and
- Any potential obstacles which would inhibit ability to make progress.

While this work is still ongoing, I have shared two responses received to give you an idea of what you can expect from this activity. I plan to have a compiled list to share with you next month.

Ideally, we will establish a practice of opening the fiscal year with an approved list of annual goals, and it would be even better if we could plan to discuss goals for the upcoming fiscal year as a part of our budget review with the Select Board each November/ December.

Town Manager Goals & Objectives - FY24

(Last Revised August 27, 2023)

CATEGORY	GOAL/OBJECTIVE	ACTION ITEMS	STATUS
Organizational Resilience	<i>Maintain a comprehensive compensation system that attracts and retains a highly competent municipal workforce.</i>	1. In conjunction with the Personnel Board, complete review of recommendations from Personnel Study Task Force report and finalize list of next steps and implementation timetable.	FY23 Carry Forward
		2. Develop a compensation strategy that aligns with the FY25 budget planning process and future years.	New
		3. Analyze the employee benefits package to identify gaps, strategies and programs that will help to attract and retain qualified personnel.	FY23 Carry Forward
		4. Analyze all Collective Bargaining Agreements, identify needed adjustments and prepare for upcoming negotiations for all CBA's expiring on June 30, 2024.	New
		5. Identify and document recruitment strategy and develop recruitment materials which highlight Concord as employer of choice, with a specific focus on inclusion. Establish employee task force to help.	New
	<i>Deliver high quality public services supported by a strong organizational structure that values efficient operations, effective management and sustainable practices.</i>	6. Fill staff vacancies; continue review organizational structure to determine if current alignment is optimal.	FY23 Carry Forward
		7. Review management and reporting structure to ensure efficient and effective operations; to enhance communications; to support optimal organizational performance; and to ensure the efficient delivery of public services.	FY23 Carry Forward
		8. Develop a long-term plan, including strategies for training, professional development and succession planning, that can guide future decision-making and supports a highly competent municipal workforce.	FY23 Carry Forward
	<i>Maintain a workforce that actively engages its knowledge, skill and talents to promote Concord's success and to deliver excellent municipal services.</i>	9. Provide regular in-house training opportunities for employees with topics that are in alignment with the Select Board's Statement of Vision and Values, promote exceptional customer service delivery model.	FY23 Carry Forward
		10. Finalize and implement "Remote Work Policy" designed to balance the provision of excellent public service and municipal operations with the needs and desires of a modern workforce.	FY23 Carry Forward
CATEGORY	GOAL/OBJECTIVE	ACTION ITEMS	STATUS
Diversity, Equity, Inclusion and Belonging	<i>Support, promote and engage economic, social, racial and cultural diversity and inclusion in the Town of Concord.</i>	11. Review May 2023 DEI Needs Assessment, develop a strategic plan that will move the Town from being (merely) EEO-compliant, to one that integrates and leverages differences to create business value; and begin implementation of plan.	New
		12. Complete a review and assessment of internal policies and practices; Identify opportunities to improve diversity, equity and inclusion efforts.	FY23 Carry Forward
		13. Continue monthly "Tea with Town Manager" providing employees with regular opportunity to connect with management outside of formal protocol.	New
		14. In conjunction with internal Professional Development Committee, institute monthly diversity training program for employees; utilize existing resources, including current employees. Rotate training venues and modalities.	New
		15. Work in collaboration with the DEI Commission to research and implement diversity, equity, and inclusion best practices for Town operations.	Ongoing
CATEGORY	GOAL/OBJECTIVE	ACTION ITEMS	STATUS

Effective Governance and Communications	<i>Support town governance by fostering effective meeting management methods.</i>	16. Evaluate automated agenda management systems to improve efficiency, functionality, and access to information; Identify resources to support Town volunteers with scheduling, facilities, compliance, training & access to information.	FY23 Carry Forward
	<i>Facilitate effective communications between Town departments.</i>	17. Institute monthly management team meetings, inclusive of SMT and division managers; work from formal agenda, providing specific opportunities for division managers to make presentations and be directly involved in problem solving.	New
	<i>Foster information sharing between the Town and Concord residents.</i>	18. Coordinate a review of the website to ensure accuracy of information; inclusion of key documents; and that it meets our functionality, utility & communication needs.	FY23 Carry Forward
	<i>Actively foster an effective and efficient governance model by engaging officials, supporting their missions, and meeting their communication needs.</i>	19. Coordinate a review of Town information to confirm Committee charges, board membership, names of officers, and ensures that contact information is up to date.	Ongoing
		20. Review all Select Board staff liaison assignments, volunteer terms, and vacancies to ensure accuracy with the Town Volunteer Database.	Ongoing
		21. Review Board and Committee operations to evaluate systems, ensure that efficient practices are in place, ensure each board and committee has a staff liaison, and recommend new procedures if needed.	Ongoing
CATEGORY	GOAL/OBJECTIVE	ACTION ITEMS	STATUS
Financial Resiliency	<i>Promote fiscal responsibility and financial sustainability.</i>	22. Plan and allocate remaining ARPA Funds; Ensure that FY25 ARPA Funds are included as a funding resource for the FY25 Budget and Capital Planning processes.	New
		23. Develop Five-Year Capital Plan for FY2025-FY2029; Include major projects, cost estimates, debt forecast and tax burden projections.	New
		24. Develop 5 and 10 Year Financial Forecasts of revenue and Non-Guidelines Expense and highlighting projection of "Available for Guidelines" to share with Finance Committee.	New
		25. In conjunction with the cross-departmental Risk Management Committee, develop a town-wide Risk Management strategy; work closely with CPS/ CCRSD to help identify and mitigate risk.	New
		26. Continue to aggressively monitor and track all grant opportunities, applying for those that meet agreed upon business need.	New
		27. Review means, methods and formulas for budgetary chargeback to Enterprise and other special revenues to ensure that they accurately capture associated costs. Continue to look for ways to streamline and/ or eliminate costs, particularly from General Fund budget.	New
CATEGORY	GOAL/OBJECTIVE	ACTION ITEMS	STATUS
Regional and State Interests	<i>Advance Concord's interests in the region and the Commonwealth.</i>	28. Continue to develop relationships with state and federal legislative delegation & staff, state leaders and municipal colleagues.	New
		29. Continue work with MWRA and neighboring communities to investigate the feasibility of regional water.	New
CATEGORY	GOAL/OBJECTIVE	ACTION ITEMS	STATUS
Economic Vitality & Strategic Planning	<i>Promote the economic vitality of the Town. Ensure implementation of recommendations, goals and objectives of key planning documents.</i>	30. In conjunction with task force, research and report on the potential acquisition of 2229 Main Street, including insurance costs, risk implications and next steps.	FY23 Carry Forward
		31. Implement strategies, innovations & staffing models to streamline permitting and regulatory processes in support of businesses, residents and visitors of Concord.	FY23 Carry Forward
		32. Identify and develop strategy to ensure implementation of recommendations, goals and objectives of key planning documents and a mechanism to track the same.	New

Town Manager FY24 Evaluation and FY25 Goal Setting	
<i>Task</i>	<i>Deadline</i>
Select Designee to compile individual evaluations	Aug 5
Adopt form to be used for evaluation	Aug 5
Determine who provides input	Aug 5
TM presents DRAFT of FY25 Goals to Select Board	Aug 19
Town manager completes self-evaluation, distributes to SB members via email	Aug 9
Each Select Board member meets with Town manager to discuss their individual evaluation	Aug 9 – Aug 30
Individual Select Board members complete evaluation, send to designee via email	Aug 30
Designee works with HR director to develop presentation of final evaluation to the community	Aug 30 – Sept 9
Compiled evaluation presented in open meeting	Sept 9
Finalize FY25 TM Goals in open meeting	Sept 9

Town of Concord
Town Manager Goals & Objectives - FY25
 18-Sep-24

CATEGORY	GOAL/OBJECTIVE	ACTION ITEMS TO SUPPORT GOAL	DESIRED OUTCOME	STATUS	STATUS UPDATE:
Strategic Planning	Implement recommendations, goals and objectives of key planning documents and remain cognizant of emerging opportunities.	1. Identify and develop strategy to ensure implementation of recommendations, goals and objectives of key planning documents and a mechanism to track the same.	Achieve alignment and community consensus on priorities, facilitating the accomplishment of key objectives with transparent tracking and accountability.		
		2. Plan for long-term utility needs continue work with MWRA and neighboring communities to investigate the feasibility of regional water.	Secure a sustainable and safe drinking water supply through regional collaboration, ensuring long-term resilience in utility infrastructure.		
	Plan for long-term utility needs	3. In conjunction with CPW and PWC, finalize Stormwater Utility fee and asset inventory and capital improvement plan.	Establish a fair and comprehensive funding mechanism for stormwater infrastructure, leading to well-planned and equitable capital expenditures.		
		4. In conjunction with DCAMM, negotiate transfer of MCI-Concord WWTP thus adding significant treatment capacity allowing for both redevelopment of MCI-Concord and beneficial infill in CWMP-area.	Facilitate redevelopment to expand the tax base while ensuring alignment with community growth priorities and increasing wastewater treatment capacity.		
CATEGORY	GOAL/OBJECTIVE	ACTION ITEMS	DESIRED OUTCOME	STATUS	STATUS UPDATE:
Financial Resilience	Promote fiscal responsibility and financial sustainability.	5. Develop Five & Ten-Year Capital Plan for FY2026-FY2035; Include major projects, cost estimates, debt forecast and tax burden projections. Format should be more-user friendly & informative than what currently exists.	Provide a transparent and user-friendly capital plan that supports long-term financial planning, minimizing tax burdens through informed decision-making.		
		6. Update methodology to fairly and accurately assign indirect costs to Enterprise and Other funds, including Recreation Revolving Fund, ensuring that user fees versus tax dollars are supporting business-type operations.	Reduce the financial burden on taxpayers by ensuring accurate cost allocation to enterprise funds and fair user fee adjustments.		
CATEGORY	GOAL/OBJECTIVE	ACTION ITEMS	DESIRED OUTCOME	STATUS	STATUS UPDATE:
Effective & Transparent Governance	Support town governance by fostering effective meeting management methods.	7. Develop standard agenda template and standard protocol for remote & hybrid meeting. Evaluate automated agenda management systems to improve efficiency, functionality, and access to information.	Improve meeting efficiency and accessibility, fostering timely decision-making and better governance through standardized protocols.		
		8. Draft IMA, or other legally appropriate agreement, to address long-standing governance issues between Town and CMLP, generally surrounding appointment powers and procurement.	Eliminate operational friction and streamline processes to enhance efficiency and collaborative decision-making.		
	Facilitate effective communications between Town departments.	9. Monthly LMT meetings, inclusive of SMT and division managers; work from formal agenda, providing specific opportunities for division managers to make presentations and be directly involved in problem solving.	Build a mission-driven organization through improved internal communication, fostering staff growth and preparing the organization for future leadership transitions.	<input checked="" type="checkbox"/>	started in July 2024
		10. Refresh of the website offered by vendor; audit for inclusion of key documents; and dedicated pages for key projects & initiatives.	Provide clear, accessible information to residents, promoting better public engagement and ensuring transparency on key projects and initiatives.		
Foster information sharing between the Town and Concord residents.	11. Bi-weekly communication from Town Manager in a newsletter format (reboot of existing report).	Enhance public satisfaction by providing transparent and regular updates, demonstrating the value of taxpayer contributions.			
	CATEGORY	GOAL/OBJECTIVE	ACTION ITEMS	DESIRED OUTCOME	STATUS
Diversity, Equity, Inclusion and Belonging	Support, promote and engage economic, social, racial and cultural diversity and inclusion in the Town of Concord.	12. Finalize a strategic plan that will move the Town from being (merely) EEO-compliant, to one that integrates and leverages differences to create business value; and begin implementation of plan.	Boost employee satisfaction and retention, contributing to improved efficiency and lower turnover costs, while fostering a diverse and inclusive workplace.		
		13. Complete a review and assessment of internal policies and practices; Identify opportunities to improve diversity, equity and inclusion efforts; incorporate best practices for Town operation	Implement best practices that reduce the risk of fraud and enhance operational efficiency, resulting in both direct savings and improved internal controls.		
CATEGORY	GOAL/OBJECTIVE	ACTION ITEMS	DESIRED OUTCOME	STATUS	STATUS UPDATE:
Organizational Resilience	A compensation plan that attracts and retains a highly competent municipal workforce.	14. Adapt existing compensation plan to create a system that recognizes growth in position resulting in value to the organization regardless of formal promotion.	Encourage employee retention and satisfaction through recognition of growth, leading to increased productivity and reduced turnover. <i>Cost of Employee Turnover Calculator.</i>		
		15. Implement a merit pay plan with a criteria-based evaluation system which provides larger increases for exceptional performance.	Reward exceptional performance to drive operational efficiencies and improve overall safety and service quality.		
		16. Document recruitment strategy and develop recruitment materials which highlight Concord as employer of choice, with a specific focus on inclusion. Develop and promote organizational branding.	Position Concord as an employer of choice, enhancing recruitment efforts and reducing risks by promoting the Town's values and safety standards.		
	Deliver high quality public services supported by a strong organizational culture that values exceptional customer service, efficient & effective operations while employing sustainable practices.	17. In conjunction with LMT, develop an organizational values statement.	Empower employees to make informed, values-driven decisions at all levels, leading to improved organizational cohesion and performance.	<input checked="" type="checkbox"/>	completed in August 2024
18. Provide regular in-house training opportunities for employees with topics that are in alignment with the Organizational Values Statement, maximizing internal talent and free trainings offered through MIIA.		Deliver cost-effective training that supports staff development and generates insurance policy credits, optimizing the Town's resources.			

Town of Concord
Select Board Goals - FY25
(July 1, 2024)

CATEGORY	GOAL/OBJECTIVE	ACTION ITEMS	Included in Current FY25 Work Plan	Additional work to be incorporated in existing FY25 Work Plan in support of Select Board Goals	Potential Obstacles	
Effective and Transparent Governance	<i>Align Boards, Committees and Senior Management Team of the Town whenever possible</i>	1. Establish goals that align and integrate between Select Board, Town Boards, Committees, Staff and town departments.				
		2. Conduct periodic joint Finance Committee and Select Board and joint School Committee and Select Board meetings.				
		3. Recommit to an annual capital planning process between the Select Board, School Committee and Finance Committee that includes Tier II and Tier III.				
	<i>Improve Committee Processes</i>	4. Periodic topical forums, such as housing, sustainability, planning and arts & culture.				
		5. Committee training, such as procurement, ethics, sexual harassment, etc.	An ethics training for all Concord committee volunteers has been scheduled for September 25th			
	<i>Improve Select Board Processes</i>	6. Ensure good process and governance; utilize data to make decisions; consider different viewpoints; delay decisions for one meeting whenever possible to enable community input.				
		7. Revise the Town flag policy.				
CATEGORY	GOAL/OBJECTIVE	ACTION ITEMS	Included in Current FY25 Work Plan	Additional work to be incorporated in existing FY25 Work Plan in support of Select Board Goals	Potential Obstacles	
Land Use Opportunities	<i>Engage the community, legislative delegation and state agencies in a robust planning process that ensures that Concord's interests are expressed and prioritized during the disposition of the MCI Concord property. Measurable outcomes include:</i>	8. Agreement(s) between the Town and the state that outline the disposition process for most of the land area.			This agreement is not likely to happen during FY25 as this concept has been pre-empted by the legislative authority of DCAMM to study and report out to the legislature on the recommended re-use of this site. That report will likely not be ready for another 18 months (February 2026).	
		9. Outline visioning and planning with broad community input.				
	<i>2229 Main Street</i>	10. Utilize the expertise of the 2229 Main Street Advisory Task Force and input from the community to determine the next steps for the 46-acre parcel at 2229 Main Street.	The Task Force is currently on track to complete their report by the October 31, 2024 deadline.			
	<i>Route 2 Rotary Improvements</i>	11. Work with State Representatives and MassSOT to advance design and implementation of Route 2 Rotary Improvements.			The interest of our state legislators and MA DOT are not aligned and this sphere of conflicting stakeholders will lead to delays in agreeing to a consensus plan, not likely to happen during FY25.	
	<i>Municipal Land Use Needs</i>	12. Work with the Senior Management Team to develop a land-use matrix and action plan to determine the best matches between municipal needs and potential land available.				
CATEGORY	GOAL/OBJECTIVE	ACTION ITEMS	Included in Current FY25 Work Plan	Additional work to be incorporated in existing FY25 Work Plan in support of Select Board Goals	Potential Obstacles	
Zoning Bylaw	<i>Warner's Pond</i>	13. Review Zoning Bylaw parking Requirements to make sure that they are consistent with industry standards and address local business concerns; propose recommended zoning amendments for 2025 Town Meeting.				
		14. Develop a road map to achieve various community objectives.				

Town Infrastructure and Planning	West Concord Master Plan	15. Review and update West Concord Master Plan by June 2025 to reflect new and evolving residential, business and industrial changes and opportunities including MCI Concord.			
	Climate Action	16. Conduct review of Climate Action Plan, document GHG reductions and progress against original blueprint recommendations and establish revised recommendations for 2025 - 2030 to achieve targeted GHG reductions for 2030 (Article 31 in 2024 Town Meeting strives for a 50% reduction in GHG emissions)			
	Take action to improve Town Infrastructure	17. Cell phone service			Based on the recommendation of staff and the Town's cell consultant, the Town needs to update its wireless overlay district and zoning bylaw to make our town more competitive with other towns that are considering hosting cell towers.
		18. Road maintenance, funding and improvements (intersections, trails, curb bump outs, etc.)			
CATEGORY	GOAL/OBJECTIVE	ACTION ITEMS	Included in Current FY25 Work Plan	Additional work to be incorporated in existing FY25 Work Plan in support of Select Board Goals	Potential Obstacles
Financial Planning and Stability	Increase Revenue Generation	19. Pursue PILOT Agreements			
		20. Evaluate Town-owned properties for possible reuse or disposition.	Can we set up a working group on this? Me, Megan, Anthony, Jess, you?		
		21. Support Concord business community to enhance local receipts.			
		22. Support tourism and programs sponsored by arts and culture groups in town.	Is it worth mentioning the Town's efforts to stand up a state/federal grants working group?		
		23. Update Revolving and Enterprise fees to reflect value of service.			
	Endorse and update Financial Stability Goals	24. Clarify 5-year priorities and expected financial impact.	While the Town's use of ARPA funds spans across several fiscal years, FY25 is the one fiscal year where we need to contractually commit all outstanding ARPA funds. This is the largest grant award the Town currently has. It will involve work by town staff to implement, reducing their capacity on other town projects. It will also reduce the dependence on taxpayer revenue in the short term for town projects. ARPA should be included as a FY25 SB/TM goal.		
	25. Work to cut costs and tighten the Town's budget in FY2026.				
CATEGORY	GOAL/OBJECTIVE	ACTION ITEMS	Included in Current FY25 Work Plan	Additional work to be incorporated in existing FY25 Work Plan in support of Select Board Goals	Potential Obstacles
Diversity, Equity and Inclusion	Create a welcoming, diverse and inclusive community	26. Protect and enhance the diversity of housing stock via continued focus on affordable housing.			
		27. Review impact and implications of the Residential Tax Exemption.			
		28. Expand underrepresented voices in Town programs and committees.	SB to update APP 10 to incorporate the need to nominate volunteers with a diversity of perspectives.		

SELECT BOARD GOALS FY 25

COMMS TOOLS	EFFECTIVE TRANSPARENT GOVERNMENT	LAND USE OPPORTUNITIES	TOWN INFRASTRUCTURE & PLANNING	FINANCIAL PLANNING & STABILITY	DIVERSITY, EQUITY, AND INCLUSION
Web	<ul style="list-style-type: none"> • Include keywords on all webpage updates to improve search capabilities • Increase use of infographics and dashboards • Include alt-text on images • Monitor color contrast on graphic images for readability for visually impaired • Consistent use of links rather than pdfs 	<ul style="list-style-type: none"> • MCI-Concord Site 	<ul style="list-style-type: none"> • Develop consistent template for communicating project process 	<ul style="list-style-type: none"> • Develop dashboards and other graphics towards a better understanding of fiscal environment 	<ul style="list-style-type: none"> • Include alt-text on images • monitor color contrast on graphic images for readability for visually impaired • Consistent use of links rather than pdfs
Weekly Report	<ul style="list-style-type: none"> • Utilize as a vehicle for telling Concord's story • Identify a new name for the report • Reconsider audience and goals • Include more stories rather than "announcements" • Infographics 	<ul style="list-style-type: none"> • Link to MCI Concord Updates and progress 	<ul style="list-style-type: none"> • Reflect successes and challenges in meeting various goals outlined in plans 	<ul style="list-style-type: none"> • Include budget timeline and planning information? • More infographics 	<ul style="list-style-type: none"> • Expand readership
Annual Report	<ul style="list-style-type: none"> • Consider more cohesive narrative • More infographics • Goal oriented (include goals and mark progress year to year) • Annual Focus? • More pictures 		<ul style="list-style-type: none"> • Reflect successes and challenges in meeting various goals outlined in plans 	<ul style="list-style-type: none"> • Infographics • Goal setting 	<ul style="list-style-type: none"> • Review for inclusion

SELECT BOARD GOALS FY 25

COMMS TOOLS	EFFECTIVE TRANSPARENT GOVERNMENT	LAND USE OPPORTUNITIES	TOWN INFRASTRUCTURE & PLANNING	FINANCIAL PLANNING & STABILITY	DIVERSITY, EQUITY, AND INCLUSION
Lobby Monitors	<ul style="list-style-type: none"> Promote meetings, campaigns, events, and other announcements in municipal buildings Integrate MMN 			<ul style="list-style-type: none"> Reduce paper clutter 	
Social Media	<ul style="list-style-type: none"> Utilize as a vehicle for telling Concord's story Review analytics to maximize views strategically 				<ul style="list-style-type: none"> include alt-text on images monitor color contrast on graphic images for readability for visually impaired



Concord Select Board Meeting
AGENDA ACTION REQUEST

Monday, September 23, 2024

13

Request for Extension of Dog Arbitration Update

Requested by: SB Chair

Action Sought: Approve

Proposed Motion(s)

Move to Extend Dog Arbitration Update

Additional Information

Board Action

<i>Motion</i>	<i>Second</i>	<i>In favor</i>	<i>Opposed</i>	<i>Disposition</i>



Town of Concord

Town Manager's Office
22 Monument Square
P.O. Box 535

Concord, Massachusetts 01742-0535

Tel: (978) 318-3000

Fax: (978) 318-3093

To: Select Board 
From: Kerry A. Lafleur, Town Manager
Date: September 18, 2024
Subject: Update on Nuisance Dog Complaint, E. Storlazzi

At your meeting of August 5, 2024, you considered the Nuisance Dog Complaint filed by Edmund Storlazzi, in consultation with Gregg Corbo, serving as special counsel for this matter. After careful consideration and review, you decided to continue the matter for forty-five (45) days, and directed the Town Manager to attempt to mediate the matter.

After further review of the case with Chief Mulcahy, it was decided that since our existing in-house resources had already been unable to mediate this matter to resolution, that we would seek outside assistance. Fortunately, we were able to secure assistance from C4RJ, *Communities for Restorative Justice*, a well-recognized organization with roots in Concord, though given vacation/ holiday schedules, it has taken more time to move forward than originally anticipated. Nevertheless, both parties have been advised of the process the Town has selected, and I have been able to confirm that both parties have voluntarily agreed to participate.

At this time, I would like to request that the Select Board vote a second continuance of this matter to October 31, 2024, to give the process time to work, and seek an update at your regularly scheduled meeting on November 4, 2024.

A copy of the C4RJ proposal is attached for your review.



Town of Concord

Town Manager's Office
22 Monument Square
P.O. Box 535

Concord, Massachusetts 01742-0535

Tel: (978) 318-3000

Fax: (978) 318-3093

September 10, 2024

Ms. Jennifer Hatfield
21-6 Concord Green
Concord, MA 01742

Mr. Edmund Storlazzi
21-8 Concord Green
Concord, MA 01742

Re: Nuisance Dog Complaint

Dear Ms. Hatfield and Mr. Storlazzi:

I am writing today regarding the above-referenced matter. To recap, in my previous correspondence dated August 13, 2024, I noted that under Massachusetts General Laws, Chapter 140, Section 157, the Concord Select Board has the authority to investigate nuisance dog complaints, including by conducting an examination of the complainant under oath, and to issue such order as may be necessary to abate the nuisance.

At a public meeting on August 5, 2024, the Select Board considered the complaint received by Mr. Storlazzi and decided not to schedule a public hearing at that time, but rather to continue the matter for a period of 45-days and asking me to arrange for mediation services.

With the understanding that our own in-house resources have been unable to resolve this conflict, we have chosen to seek external assistance through C4RJ, *Communities for Restorative Justice*, who will assist with and facilitate a restorative conversation in an attempt to find a solution. This process is completely voluntary and more fully outlined in the attached proposal from C4RJ's Executive Director, Erin Freeborn.

Within the next week, you will be contacted by C4RJ, at which time you will be asked whether you will engage in this process. As long as you are engaged in this process, the Select Board will hold this complaint in abeyance. If you choose not to participate, the Select Board will be notified and will then be required to decide whether to proceed with a public hearing.

Thank you for your cooperation in this regard.

Sincerely,

Kerry A. Lafleur
Town Manager



Proposal for a Restorative Conversation led by C4RJ

To: Town Manager Kerry Lafleur
Date: September 8, 2024
From: Communities for Restorative Justice, Inc. (C4RJ)
Subject: Proposal for Restorative Conversations led by C4RJ

Dear Town Manager Lafleur,

Communities for Restorative Justice, Inc (C4RJ) is a dedicated team committed to facilitating engagement between people after harm. We are writing to propose a ***pilot approach for neighbor disputes that rise to the level of police and select board engagement***. Our goal is to offer a structure and support for parties to have difficult conversations in an attempt to find a better way to coexist in community.

This voluntary process will be offered by the town, and if accepted by the parties, 1-2 intake meetings will be conducted by C4RJ with each side. After the intake phase C4RJ will propose a timeline and strategy for the circle process to the Town Manager. The goal of this initiative is to bring the impacted residents together to talk about the conflict at Concord Greene Condominiums regarding a nuisance dog and to create a plan about how to move forward.

Objectives of each stage:

1. **Intake meetings** - C4RJ representatives will meet with the parties to better understand the harm experienced by residents and its impact on their lives.
2. **Circle** - C4RJ representatives will facilitate a restorative conversation between the impacted residents, their supporters and necessary members of the Town or police (if relevant, i.e. Animal Control Officer).
3. **Agreement** - C4RJ representatives will draft an agreement at the circle that includes the mutually agreed upon outcomes discussed in the circle.
4. **Follow up** - C4RJ will draft a one page memo, for the Town Manager, documenting the date of the circle, agreement items, and recommended next step.



The work will be conducted by C4RJ staff or trained Concord community members at a rate of _____ per hour, in quarter hour increments. An invoice will be provided for the Town Manager monthly and at the end of the process.

We look forward to the opportunity to discuss this proposal further and to answer any questions you may have.

Sincerely,

Erin V. Freeborn
Executive Director
Communities for Restorative Justice



Town of Concord

Town Manager's Office
22 Monument Square
P.O. Box 535

Concord, Massachusetts 01742-0535

Tel: (978) 318-3000

Fax: (978) 318-3093

August 13, 2024

Ms. Jennifer Hatfield
21-6 Concord Green
Concord, MA 01742

Mr. Edmund Storlazzi
21-8 Concord Green
Concord, MA 01742

Re: Nuisance Dog Complaint

Dear Ms. Hatfield and Mr. Storlazzi:

Please be advised that the Town of Concord Select Board is in receipt of a complaint from Mr. Storlazzi that a dog owned or kept by Ms. Hatfield at 21-6 Concord Green, Concord, MA, is a nuisance dog as that term is defined in Massachusetts General Laws, Chapter 140, Section 136A. A copy of the complaint is enclosed herewith for your reference.

According to Massachusetts General Laws, Chapter 140, Section 157, the Town of Concord Select Board has the authority to investigate such complaint, including by conducting an examination of the complainant under oath, and to issue such order as may be necessary to abate the nuisance.

At a public meeting on August 5, 2024, the Select Board considered Mr. Storlazzi's complaint and decided not to schedule a public hearing at this time. Rather, the Board has continued the matter, and it is requesting that both of you meet with a representative of the Town Manager to discuss the issues and try to reach a resolution without having to go through a public hearing process.

I am in the process of arranging for you to meet with an independent mediator who will work to reach a resolution. Once the mediator's availability is provided, my office will be back in touch with you. You should expect to hear from us no later than August 30, 2024.

Please be advised that the meeting will only be held if you both agree. If you do not wish to attend a meeting or if you are unable to agree to a solution, the Select Board will consider this matter further at a meeting on September 23, 2024, and at that time it will decide whether to schedule a public hearing.

Thank you for your cooperation in this regard.

Sincerely,

Kerry A. Lafleur

Note: original request was submitted on May 1, 2024. Applicant was provided the opportunity to re-submit request to remove certain personal information.

**SUBSTITUTE SUBMISSION FOR BOARD-MEETING
WHETHER ALLOW APPEAL TO "DOG COMMITTEE".**

. CONCORD GREENE RULES Par. D4 "Pet Owners shall not permit their pet[s] to disturb the peace or quiet of any neighborhood or endanger the safety of any person by biting, barking, howling, or in any other manner

TOWN OF CONCORD MASSACHUSETTS DOG BYLAW

Section 2. No owner of a dog shall permit such dog: a. to disturb the peace or quiet of any neighborhood or endanger the safety of any person, by biting, barking, howling, or in any other manner.

. For the past two years, I have been appealing to the owner of a dog, CG Management, Animal Control, and CPD to intervene to permanently stop violations of the above policies outside the door of my residence, and in the common area adjacent to my door, that involve intermittent day, evening, and night barking and high-pitched screeching

of the dog whenever I access my apt, and while I am quietly residing inside.

. The owner has refused to stop the disturbance, and refused my request to meet to devise a plan to permanently end her dog's disturbance with her justification being that the disturbance is not of sufficient duration and frequency to require her permanent-stopping action.

. A state of animosity exists between myself and the owner for various other reasons involving safety/health risk policy-violations occurring at CG, and my asking the intervention of the CPD for a threatening item placed at my door, and an incident of verbal intimidation by her male friend .

. CG Management has refused to stop the disturbance, and refused my request for a meeting of all parties to devise a plan to compel the owner to permanently end the dog's disturbance in violation of CG policy. Their justification is concern for adversity between myself and the dog's owner, despite my contrary assurance; and after their individual "fact-finding" assertion that their is insufficient duration and frequency of the disturbance to require their policy-enforcement.

. A few years ago, CG Management was subject to an adverse ruling by the MCAD for demanding that I pay for the cost of installing a stair lift I requested to accommodate military- service leg injuries disability. I was also awarded punitive damages of \$5000, and they were required to attend disability-awareness classes.

. Animal Control has indicated that they can not/will not enforce town policy against the owner due to insufficient duration and frequency of the dog disturbance; and that their request on my behalf to CG Management and the owner for a meeting of all parties to devise a plan to permanently end the disturbance was rejected.

. CPD informed me that because of the intermittent nature of the disturbance, they can not act to permanently stop the disturbance.

. I receive 100% disability-compensation from the Dept. of Veterans Affairs for physical and ptsd injuries from my service as a US Army Civil Affairs Officer with 4th Infantry Div in Viet Nam at the time of the Communist TET Offensive, for which I was awarded the Bronze Star.

. I personally experienced surviving sudden rocket attacks and land-mine explosions, including one incident where I was the remaining uninjured officer on a mission,

and had to arrange ambush-security and military helicopter evacuation of wounded, screaming personnel in a combat environment.

. About 6 months ago, I began to experience physical startle, jumping, breathing- interruption, racing heart-beat symptoms from the day and evening recurring incidents of the dog's sudden screeching.

. I was referred for treatment by the VA for this condition which is ongoing, about which the dog-owner and CG have been informed.

. I have been informed from therapy that the dog's intermittent sudden screeching/barking is acting as a trigger to the ptsd physical startle and alarm reactions, sleep disturbance, and general stress/anxiety that I am experiencing.

Edmund Storlazzi