

# ***DRAINAGE REPORT***

*For*

***Concord Country Store LLC***

***PROPOSED***

***Country Store and Auto Service Station***

***166 Commonwealth Avenue  
Concord, Massachusetts  
Middlesex County***

Prepared by:

BOHLER ENGINEERING  
50 Washington Street – Suite 2000  
Westborough, MA 01581  
(508) 480-9900 TEL.



John A. Kucich  
Massachusetts P.E. Lic. #41530

**BOHLER //**

December 18, 2025  
#MAA250062.00

**TABLE OF CONTENTS**

- I. EXECUTIVE SUMMARY..... 1
- II. EXISTING SITE CONDITIONS ..... 3
  - Existing Site Description..... 3
  - On-Site Soil Information ..... 3
  - Existing Collection and Conveyance ..... 3
  - Existing Watersheds and Design Point Information..... 3
- III. PROPOSED SITE CONDITIONS..... 5
  - Proposed Development Description ..... 5
  - Proposed Development Collection and Conveyance ..... 5
  - Proposed Watersheds and Design Point Information..... 5
- IV. METHODOLOGY ..... 7
  - Peak Flow Calculations ..... 7
- V. STORMWATER MANAGEMENT STANDARDS..... 8
  - Standard #1: No New Untreated Discharges ..... 8
  - Standard #2: Peak Rate Attenuation ..... 8
  - Standard #3: Recharge ..... 8
  - Standard #4: Water Quality ..... 8
  - Standard #5: Land Use with Higher Potential Pollutant Loads ..... 9
  - Standard #6: Critical Areas ..... 9
  - Standard #7: Redevelopment..... 9
  - Standard #8: Construction Period Pollution Prevention and Erosion and Sedimentation Control..... 9
  - Standard #9: Operation and Maintenance Plan (O&M Plan)..... 9
  - Standard #10: Prohibition of Illicit Discharges ..... 10
- VI. SUMMARY ..... 10

**LIST OF TABLES**

Table 1.1: Design Point Peak Runoff Rate Summary ..... 1

Table 1.2: Design Point Volume Summary..... 2

Table 2.1: Existing Soil Information..... 3

Table 2.2: Existing Sub-Catchment Summary..... 4

Table 3.1: Proposed Sub-catchment Summary..... 6

Table 4.1: NOAA Rainfall Intensities ..... 7

Table 6.1: Design Point Peak Runoff Rate Summary ..... 10

Table 6.2: Design Point Volume Summary..... 10

**APPENDICES**

APPENDIX A: MASSACHUSETTS STORMWATER MANAGEMENT CHECKLIST

APPENDIX B: PROJECT LOCATION MAPS

- USGS MAP
- FEMA FIRMETTE

APPENDIX C: SOIL AND WETLAND INFORMATION

- NCRS CUSTOM SOIL RESOURCE REPORT
- WETLAND BORDER REPORT

APPENDIX D: EXISTING CONDITIONS HYDROLOGIC ANALYSIS

- EXISTING CONDITIONS DRAINAGE MAP
- EXISTING CONDITIONS HYDROCAD COMPUTATIONS

APPENDIX E: PROPOSED CONDITIONS HYDROLOGIC ANALYSIS

- PROPOSED CONDITIONS DRAINAGE MAP
- PROPOSED CONDITIONS HYDROCAD CALCULATIONS

APPENDIX F: STORMWATER CALCULATIONS

- MA STANDARD #3 – RECHARGE AND DRAWDOWN TIME
- MA STANDARD #4 – WATER QUALITY AND TSS REMOVAL
- NOAA RAINFALL DATA
- PIPE AND INLET SIZING
- OUTLET PROTECTION SIZING

APPENDIX G: OPERATION AND MAINTENANCE

- STORMWATER OPERATION AND MAINTENANCE PLAN
- INSPECTION REPORT
- INSPECTION AND MAINTENANCE LOG FORM
- LONG-TERM POLLUTION PREVENTION PLAN
- ILLICIT DISCHARGE STATEMENT
- SPILL PREVENTION
- PROPOSED OPERATION AND MAINTENANCE MAP
- MANUFACTURER'S INSPECTION AND MAINTENANCE MANUALS

## I. EXECUTIVE SUMMARY

This report examines the changes in drainage that can be expected as the result of the development of a proposed country store and fueling facility located at 166 Commonwealth Avenue in the Town of Concord, Massachusetts. The site, which contains approximately 0.48 acres of land, consists of an existing motor vehicle service station and fueling facility along with paved parking areas, underground fuel storage, and associated utilities. Nashoba Brook and the associated 25-FT “No Disturbance Zone”, 100-FT “Limited Disturbance Zone”, and the 200-FT Riverfront Area fall within the northern portion of the property. Existing disturbance within these buffers consists of paved parking areas, retaining walls, the existing building, fueling facility, underground fuel storage, and utilities.

The proposed project includes the construction of a new 2,162± SF freestanding country store and self-service gasoline station with an 800± SF canopy along with new paved parking areas, landscaping, storm water management components and associated utilities. This report addresses a comparative analysis of the pre- and post-development site runoff conditions. Additionally, this report provides calculations documenting the design of the proposed stormwater conveyance/management system as illustrated within the accompanying Site Development Plans prepared by Bohler. The project will also provide erosion and sedimentation controls during the demolition and construction periods, as well as long term stabilization of the site.

For the purposes of this analysis the pre- and post-development drainage conditions were analyzed at one (1) “design point” where stormwater runoff currently drains to under existing conditions. This design point is described in further detail in **Section II** below. A summary of the existing and proposed conditions peak runoff rates and volumes for the 2-, 10-, 25-, and 100-year storms can be found in **Table 1.1** and **Table 1.2** below. In addition, the project has been designed to meet or exceed the Stormwater Management Standards as detailed herein.

**Table 1.1: Design Point Peak Runoff Rate Summary**

Point of Analysis	2-Year Storm			10-Year Storm			25-Year Storm			100-Year Storm		
	Pre	Post	Δ	Pre	Post	Δ	Pre	Post	Δ	Pre	Post	Δ
<b>DP1</b>	1.52	1.37	<b>-0.15</b>	2.39	2.19	<b>-0.20</b>	2.93	2.71	<b>-0.22</b>	3.77	3.53	<b>-0.24</b>

*\*Flows are represented in cubic feet per second (cfs)*

**Table 1.2: Design Point Volume Summary**

Point of Analysis	2-Year Storm			10-Year Storm			25-Year Storm			100-Year Storm		
	Pre	Post	$\Delta$	Pre	Post	$\Delta$	Pre	Post	$\Delta$	Pre	Post	$\Delta$
<b>DP1</b>	0.121	0.096	<b>-0.025</b>	0.194	0.165	<b>-0.029</b>	0.239	0.209	<b>-0.030</b>	0.310	0.277	<b>-0.033</b>

*\*Volumes are represented in acre-feet (ac-ft)*

## II. EXISTING SITE CONDITIONS

### Existing Site Description

The site consists of approximately 0.48 acres of land located at 166 Commonwealth Avenue in the Town of Concord, Massachusetts. The site consists of an existing motor vehicle service station and fueling facility along with paved parking areas, underground fuel storage, and associated utilities

### On-Site Soil Information

Soils within the analyzed area consist of the following as classified by the Natural Resource Conservation Service (NRCS):

**Table 2.1: Existing Soil Information**

Soil Unit Symbol	Soil Name / Description	Hydrologic Soil Group (HSG)
626B	Merrimac-Urban land complex	A
602	Urban land	C/D

Refer to **Appendix C** for additional information.

### Existing Collection and Conveyance

The majority of the site drains overland to the north towards the existing retaining wall where runoff flows through a small pipe off property and discharges to Nashoba Brook. A small portion along the westerly side of the site drains to existing catch basins within Commonwealth Avenue which then conveys the runoff through the existing municipal drainage system and discharges into Nashoba Brook. Slopes on the site range from less than 1% to 30% with on-site elevations ranging from 126.5± at the southeastern corner of the property along Commonwealth Avenue to 120.5± at the northwestern portion of the property along Nashoba Brook.

### Existing Watersheds and Design Point Information

For the purposes of this analysis, the pre- and post-development drainage conditions were analyzed at one (1) “design point” as described below where stormwater runoff currently drains to under existing conditions. The existing site was subdivided into two (2) separate sub catchments, as described below, to analyze existing and proposed flow rates at each design point. The minimum time of concentration for all proposed areas is calculated as 6 minutes (0.1 hr).

Design Point #1 (DP1) is Nashoba Brook. Under existing conditions, this design point receives stormwater flows from approximately 0.51 acres of land, designated as watersheds “ED1.1” and “ED1.2”. Refer to Table 2.1 below for additional detail.

**Table 2.2: Existing Sub-Catchment Summary**

<b>Sub-catchment Name</b>	<b>Total Area (acres)</b>	<b>Cover Description</b>	<b>Curve Number (CN)</b>	<b>Time of Concentration (Tc, minutes)</b>
ED1.1	0.42±	Rooftops, paved parking, grass	95	6.0
ED1.2	0.09±	paved parking, grass	98	6.0

Refer to **Table 1.1, 1.2, 6.1, and 6.2** for the existing conditions peak rates of runoff and volumes. Refer to **Appendix D** and the Drainage Area Maps in the appendices of this report for a graphical representation of the existing drainage areas.

### III. PROPOSED SITE CONDITIONS

#### **Proposed Development Description**

The proposed project consists of the construction of a new 2,162± SF freestanding country store and self-service gasoline station with an 800± SF canopy along with new paved parking areas, landscaping, associated utilities, and a new stormwater management system. The majority of the site, including a portion of the proposed parking areas and the entire building roof and fuel canopy, has been designed to drain to deep-sump, hooded catch basins. The catch basins will capture and convey stormwater runoff, via an underground pipe system, to an infiltration trench consisting of a perforated pipe wrapped in stone prior to discharging towards Nashoba Brook. Pretreatment of stormwater runoff will be provided by a combination of the deep-sump, hooded catch basins and one (1) proprietary treatment unit prior to discharge into the proposed infiltration trench. Rooftop runoff has been designed to flow to the infiltration trench as well. The proposed landscaped area of the site along the existing retaining wall within the northerly portion of the site has been designed to drain overland towards the existing retaining wall and discharge to Nashoba Brook similar to existing conditions. The remainder of the site drains towards Commonwealth Avenue where runoff is captured within the existing municipal drainage system and discharges to Nashoba Brook.

#### **Proposed Development Collection and Conveyance**

Deep sump hooded catch basins are proposed to collect and route runoff from the paved parking areas to a proposed infiltration trench consisting of a flat perforated pipe wrapped in stone with an overflow outlet that discharges towards Nashoba Brook. Pipes have been designed for the 25-year storm using Rational Method. Pipe, inlet, and outlet protection sizing calculations are included in **Appendix F**.

The best management practices (BMPs) incorporated into the proposed stormwater management system have been designed to meet, or exceed, the standards set forth in the Massachusetts Department of Environmental Protection Stormwater Handbook standards. Refer to **Section V** for additional information.

#### **Proposed Watersheds and Design Point Information**

The project has been designed to maintain existing drainage watersheds to the greatest extent possible, with the same design point described in **Section II** above. The site was subdivided into

three (3) separate sub catchments for the proposed conditions as described below. The minimum time of concentration for all proposed areas is calculated as 6 minutes (0.1 hr).

Under proposed conditions DP1 receives stormwater flows from approximately 0.51 acres of land, designated as watershed "PD1.1" and "PD1.2". Refer to Table 3.1 below for additional detail.

**Table 3.1: Proposed Sub-catchment Summary**

<b>Sub-catchment Name</b>	<b>Total Area (acres)</b>	<b>Cover Description</b>	<b>Curve Number (CN)</b>	<b>Time of Concentration (Tc, minutes)</b>	<b>Hydrologic Routing</b>
PD1.1	0.36±	Rooftops, paved parking, grass	67	6.0	BMP-1 / DP1
PD1.2	0.06±	Paved parking, grass	97	6.0	DP1
PD1.3	0.09±	Sidewalks, grass	98	6.0	DP1

Refer to **Table 1.1, 1.2, 6.1, and 6.2** for the calculated proposed conditions peak rates of runoff and volumes. For additional hydrologic information, refer to **Appendix D** and the Drainage Area Maps in the appendices of this report for a graphical representation of the proposed drainage areas.

#### IV. METHODOLOGY

##### **Peak Flow Calculations**

Methodology utilized to design the proposed stormwater management system includes compliance with the guidelines set forth in the latest edition of the Massachusetts DEP Stormwater Handbook. The pre- and post-development runoff rates being discharged from the site were computed using the HydroCAD computer program. The drainage area and outlet information were entered into the program, which routes storm flows based on NRCS TR-20 and TR-55 methods. The other components of the model were determined following standard NRCS procedures for Curve Numbers (CNs) and times of concentrations documented in the appendices of this report. The rainfall data utilized and listed below in Table 4.1 below for stormwater calculations is based on NOAA. Refer to **Appendix F** for more information.

**Table 4.1: NOAA Rainfall Intensities**

Frequency	2 year	10 year	25 year	100 year
Rainfall* (inches)	3.23	5.02	6.14	7.87

\*Values derived from NOAA ATLAS on 11/19/2025

The proposed stormwater management as designed will provide a decrease in peak rates of runoff from the proposed facility for the 2-, 10-, 25- and 100-year design storm events. Additionally, the proposed project meets, or exceeds, the MADEP Stormwater Management standards. Compliance with these standards is described further below.

## V. STORMWATER MANAGEMENT STANDARDS

### **Standard #1: No New Untreated Discharges**

The proposed redevelopment project is anticipated to result in a reduction of 2,633± SF of impervious coverage and no new untreated discharges are anticipated. The proposed stormwater management system has been designed so that majority of proposed impervious areas (including the building roof and fuel canopy) to the maximum extent practicable shall be collected and passed through the proposed drainage system for treatment prior to discharge.

### **Standard #2: Peak Rate Attenuation**

As outlined in **Table 1.1** and **Table 6.1**, the development of the site and the proposed stormwater management system, have been designed so that post-development peak rates of runoff are below pre-development conditions for the 2-, 10-, 25- and 100-year storm events at all design points.

### **Standard #3: Recharge**

The proposed project is a redevelopment and is required to meet Standard 3 to the maximum extent practicable. The project is anticipated to result in a reduction of 2,633± SF of impervious coverage. Additionally, the majority of the paved parking areas along with the entire building roof and fuel canopy have been designed to be collected and diverted to a proposed infiltration trench consisting of a perforated pipe wrapped in stone. The overflow from the infiltration trench is designed to discharge to Nashoba Brook. The proposed infiltration trench will provide 87 cubic feet of volume below the lowest outlet for groundwater recharge. Refer to **Appendix F** of this report for calculations documenting required and provided recharge volumes.

The DEP Stormwater Standards require that the infiltration BMP drains completely within 72 hours of the end of the storm event. Calculations showing that the proposed infiltration basin will drain within 3.6 hours are included in **Appendix F** of this report.

### **Standard #4: Water Quality**

The proposed redevelopment is anticipated to result in a reduction of 2,633± SF of impervious coverage. To the maximum extent practicable, water quality treatment is provided to stormwater runoff directed to the proposed deep sump catch basins, which is then conveyed to one (1) proprietary water quality treatment unit and an underground infiltration trench prior to discharge. The proposed stormwater management system is anticipated to obtain a minimum TSS removal

of 98%. Refer to **Appendix F** of this report for calculations documenting required and provided water quality volumes.

#### **Standard #5: Land Use with Higher Potential Pollutant Loads**

The proposed project involves “Land Uses with Higher Potential Pollutant Loads”. Accordingly, the stormwater management system includes an oil-grit separator (Stormceptor unit) prior to discharge. In addition, the project will provide 44% TSS removal prior to infiltration and treat the 1.0 in water quality depth, as further illustrated in **Appendix F** of this report.

#### **Standard #6: Critical Areas**

Not Applicable for this project.

#### **Standard #7: Redevelopment**

The project is a redevelopment and has been designed to meet the Massachusetts Stormwater Management regulations to the maximum extent practicable.

#### **Standard #8: Construction Period Pollution Prevention and Erosion and Sedimentation Control**

The proposed project will provide construction period erosion and sedimentation controls as indicated within the site plan set provided for this project. This includes a proposed construction exit, protection for stormwater inlets, protection around temporary material stock piles and various other techniques as outlined on the erosion and sediment control sheets. Additionally, the project is required to file a Notice of Intent with the US EPA and implement a Stormwater Pollution Prevention Plan (SWPPP) during the construction period. The SWPPP will be prepared prior to the start of construction and will be implemented by the site contractor under the guidance and responsibility of the project’s proponent. Refer to **Appendix G**.

#### **Standard #9: Operation and Maintenance Plan (O&M Plan)**

An Operation and Maintenance (O&M) Plan for this site has been prepared and is included in **Appendix G** of this report. The O&M Plan outlines procedures and time tables for the long term operation and maintenance of the proposed site stormwater management system, including initial inspections upon completion of construction, and periodic monitoring of the system components, in accordance with established practices and the manufacturer’s recommendations. The O&M Plan includes a list of responsible parties and an estimated budget for inspections and maintenance.

## Standard #10: Prohibition of Illicit Discharges

The proposed stormwater system will only convey allowable non-stormwater discharges (firefighting waters, irrigation, air conditioning condensates, etc.) and will not contain any illicit discharges from prohibited sources. An Illicit Discharge Statement is included in **Appendix G** of this report.

## VI. SUMMARY

In summary, the proposed stormwater management system illustrated on the drawings prepared by Bohler results in a reduction in peak rates of runoff and volumes from the subject site when compared to pre-development conditions for the 2-, 10-, 25- and 100-year storm frequencies. In addition, the proposed best management practices will result in an effective removal of total suspended solids from the post-development runoff. The pre-development versus post-development stormwater discharge comparisons are contained in **Table 6.1** and **Table 6.2** below:

**Table 6.1: Design Point Peak Runoff Rate Summary**

Point of Analysis	2-Year Storm			10-Year Storm			25-Year Storm			100-Year Storm		
	Pre	Post	Δ	Pre	Post	Δ	Pre	Post	Δ	Pre	Post	Δ
<b>DP1</b>	1.52	1.37	<b>-0.15</b>	2.39	2.19	<b>-0.20</b>	2.93	2.71	<b>-0.22</b>	3.77	3.53	<b>-0.24</b>

*\*Flows are represented in cubic feet per second (cfs)*

**Table 6.2: Design Point Volume Summary**

Point of Analysis	2-Year Storm			10-Year Storm			25-Year Storm			100-Year Storm		
	Pre	Post	Δ	Pre	Post	Δ	Pre	Post	Δ	Pre	Post	Δ
<b>DP1</b>	0.121	0.096	<b>-0.025</b>	0.194	0.165	<b>-0.029</b>	0.239	0.209	<b>-0.030</b>	0.310	0.277	<b>-0.033</b>

*\*Volumes are represented in acre-feet (ac-ft)*

As outlined in the tables above, the proposed stormwater management system as designed will provide a decrease in peak rates of runoff from the proposed facility for the 2-, 10-, 25- and 100-year storm events. The project is anticipated to result in a reduction of 2,633± SF of impervious coverage while providing improved groundwater recharge and water quality from pre-development. Additionally, the project meets or exceeds the MADEP Stormwater Management Standards as described further herein.

**APPENDIX A: MASSACHUSETTS STORMWATER MANAGEMENT CHECKLIST**



# Checklist for Stormwater Report

## A. Introduction

**Important:** When filling out forms on the computer, use only the tab key to move your cursor - do not use the return key.



A Stormwater Report must be submitted with the Notice of Intent permit application to document compliance with the Stormwater Management Standards. The following checklist is NOT a substitute for the Stormwater Report (which should provide more substantive and detailed information) but is offered here as a tool to help the applicant organize their Stormwater Management documentation for their Report and for the reviewer to assess this information in a consistent format. As noted in the Checklist, the Stormwater Report must contain the engineering computations and supporting information set forth in Volume 3 of the [Massachusetts Stormwater Handbook](#). The Stormwater Report must be prepared and certified by a Registered Professional Engineer (RPE) licensed in the Commonwealth.

The Stormwater Report must include:

- The Stormwater Checklist completed and stamped by a Registered Professional Engineer (see page 2) that certifies that the Stormwater Report contains all required submittals.<sup>1</sup> This Checklist is to be used as the cover for the completed Stormwater Report.
- Applicant/Project Name
- Project Address
- Name of Firm and Registered Professional Engineer that prepared the Report
- Long-Term Pollution Prevention Plan required by Standards 4-6
- Construction Period Pollution Prevention and Erosion and Sedimentation Control Plan required by Standard 8<sup>2</sup>
- Operation and Maintenance Plan required by Standard 9

In addition to all plans and supporting information, the Stormwater Report must include a brief narrative describing stormwater management practices, including environmentally sensitive site design and LID techniques, along with a diagram depicting runoff through the proposed BMP treatment train. Plans are required to show existing and proposed conditions, identify all wetland resource areas, NRCS soil types, critical areas, Land Uses with Higher Potential Pollutant Loads (LUHPPL), and any areas on the site where infiltration rate is greater than 2.4 inches per hour. The Plans shall identify the drainage areas for both existing and proposed conditions at a scale that enables verification of supporting calculations.

As noted in the Checklist, the Stormwater Management Report shall document compliance with each of the Stormwater Management Standards as provided in the Massachusetts Stormwater Handbook. The soils evaluation and calculations shall be done using the methodologies set forth in Volume 3 of the Massachusetts Stormwater Handbook.

To ensure that the Stormwater Report is complete, applicants are required to fill in the Stormwater Report Checklist by checking the box to indicate that the specified information has been included in the Stormwater Report. If any of the information specified in the checklist has not been submitted, the applicant must provide an explanation. The completed Stormwater Report Checklist and Certification must be submitted with the Stormwater Report.

<sup>1</sup> The Stormwater Report may also include the Illicit Discharge Compliance Statement required by Standard 10. If not included in the Stormwater Report, the Illicit Discharge Compliance Statement must be submitted prior to the discharge of stormwater runoff to the post-construction best management practices.

<sup>2</sup> For some complex projects, it may not be possible to include the Construction Period Erosion and Sedimentation Control Plan in the Stormwater Report. In that event, the issuing authority has the discretion to issue an Order of Conditions that approves the project and includes a condition requiring the proponent to submit the Construction Period Erosion and Sedimentation Control Plan before commencing any land disturbance activity on the site.



# Checklist for Stormwater Report

---

## B. Stormwater Checklist and Certification

The following checklist is intended to serve as a guide for applicants as to the elements that ordinarily need to be addressed in a complete Stormwater Report. The checklist is also intended to provide conservation commissions and other reviewing authorities with a summary of the components necessary for a comprehensive Stormwater Report that addresses the ten Stormwater Standards.

*Note:* Because stormwater requirements vary from project to project, it is possible that a complete Stormwater Report may not include information on some of the subjects specified in the Checklist. If it is determined that a specific item does not apply to the project under review, please note that the item is not applicable (N.A.) and provide the reasons for that determination.

A complete checklist must include the Certification set forth below signed by the Registered Professional Engineer who prepared the Stormwater Report.

---

### Registered Professional Engineer's Certification

I have reviewed the Stormwater Report, including the soil evaluation, computations, Long-term Pollution Prevention Plan, the Construction Period Erosion and Sedimentation Control Plan (if included), the Long-term Post-Construction Operation and Maintenance Plan, the Illicit Discharge Compliance Statement (if included) and the plans showing the stormwater management system, and have determined that they have been prepared in accordance with the requirements of the Stormwater Management Standards as further elaborated by the Massachusetts Stormwater Handbook. I have also determined that the information presented in the Stormwater Checklist is accurate and that the information presented in the Stormwater Report accurately reflects conditions at the site as of the date of this permit application.

Registered Professional Engineer Block and Signature

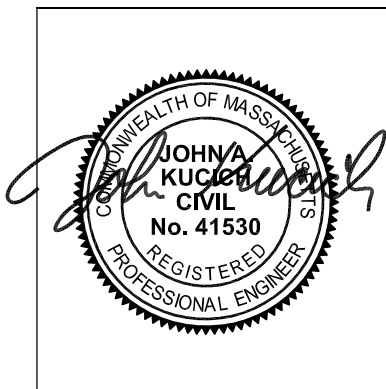

12/18/2025

Signature and Date

---

## Checklist

**Project Type:** Is the application for new development, redevelopment, or a mix of new and redevelopment?

- New development
- Redevelopment
- Mix of New Development and Redevelopment



# Checklist for Stormwater Report

---

## Checklist (continued)

**LID Measures:** Stormwater Standards require LID measures to be considered. Document what environmentally sensitive design and LID Techniques were considered during the planning and design of the project:

- No disturbance to any Wetland Resource Areas
- Site Design Practices (e.g. clustered development, reduced frontage setbacks)
- Reduced Impervious Area (Redevelopment Only)
- Minimizing disturbance to existing trees and shrubs
- LID Site Design Credit Requested:
  - Credit 1
  - Credit 2
  - Credit 3
- Use of "country drainage" versus curb and gutter conveyance and pipe
- Bioretention Cells (includes Rain Gardens)
- Constructed Stormwater Wetlands (includes Gravel Wetlands designs)
- Treebox Filter
- Water Quality Swale
- Grass Channel
- Green Roof
- Other (describe): \_\_\_\_\_

### Standard 1: No New Untreated Discharges

- No new untreated discharges
- Outlets have been designed so there is no erosion or scour to wetlands and waters of the Commonwealth
- Supporting calculations specified in Volume 3 of the Massachusetts Stormwater Handbook included.



# Checklist for Stormwater Report

---

## Checklist (continued)

### Standard 2: Peak Rate Attenuation

- Standard 2 waiver requested because the project is located in land subject to coastal storm flowage and stormwater discharge is to a wetland subject to coastal flooding.
- Evaluation provided to determine whether off-site flooding increases during the 100-year 24-hour storm.
- Calculations provided to show that post-development peak discharge rates do not exceed pre-development rates for the 2-year and 10-year 24-hour storms. If evaluation shows that off-site flooding increases during the 100-year 24-hour storm, calculations are also provided to show that post-development peak discharge rates do not exceed pre-development rates for the 100-year 24-hour storm.

### Standard 3: Recharge

- Soil Analysis provided.
- Required Recharge Volume calculation provided.
- Required Recharge volume reduced through use of the LID site Design Credits.
- Sizing the infiltration, BMPs is based on the following method: Check the method used.
  - Static
  - Simple Dynamic
  - Dynamic Field<sup>1</sup>
- Runoff from all impervious areas at the site discharging to the infiltration BMP.
- Runoff from all impervious areas at the site is *not* discharging to the infiltration BMP and calculations are provided showing that the drainage area contributing runoff to the infiltration BMPs is sufficient to generate the required recharge volume.
- Recharge BMPs have been sized to infiltrate the Required Recharge Volume.
- Recharge BMPs have been sized to infiltrate the Required Recharge Volume *only* to the maximum extent practicable for the following reason:
  - Site is comprised solely of C and D soils and/or bedrock at the land surface
  - M.G.L. c. 21E sites pursuant to 310 CMR 40.0000
  - Solid Waste Landfill pursuant to 310 CMR 19.000
  - Project is otherwise subject to Stormwater Management Standards only to the maximum extent practicable.
- Calculations showing that the infiltration BMPs will drain in 72 hours are provided.
- Property includes a M.G.L. c. 21E site or a solid waste landfill and a mounding analysis is included.

---

<sup>1</sup> 80% TSS removal is required prior to discharge to infiltration BMP if Dynamic Field method is used.



# Checklist for Stormwater Report

---

## Checklist (continued)

### Standard 3: Recharge (continued)

- The infiltration BMP is used to attenuate peak flows during storms greater than or equal to the 10-year 24-hour storm and separation to seasonal high groundwater is less than 4 feet and a mounding analysis is provided.
- Documentation is provided showing that infiltration BMPs do not adversely impact nearby wetland resource areas.

### Standard 4: Water Quality

The Long-Term Pollution Prevention Plan typically includes the following:

- Good housekeeping practices;
  - Provisions for storing materials and waste products inside or under cover;
  - Vehicle washing controls;
  - Requirements for routine inspections and maintenance of stormwater BMPs;
  - Spill prevention and response plans;
  - Provisions for maintenance of lawns, gardens, and other landscaped areas;
  - Requirements for storage and use of fertilizers, herbicides, and pesticides;
  - Pet waste management provisions;
  - Provisions for operation and management of septic systems;
  - Provisions for solid waste management;
  - Snow disposal and plowing plans relative to Wetland Resource Areas;
  - Winter Road Salt and/or Sand Use and Storage restrictions;
  - Street sweeping schedules;
  - Provisions for prevention of illicit discharges to the stormwater management system;
  - Documentation that Stormwater BMPs are designed to provide for shutdown and containment in the event of a spill or discharges to or near critical areas or from LUHPPL;
  - Training for staff or personnel involved with implementing Long-Term Pollution Prevention Plan;
  - List of Emergency contacts for implementing Long-Term Pollution Prevention Plan.
- A Long-Term Pollution Prevention Plan is attached to Stormwater Report and is included as an attachment to the Wetlands Notice of Intent.
  - Treatment BMPs subject to the 44% TSS removal pretreatment requirement and the one inch rule for calculating the water quality volume are included, and discharge:
    - is within the Zone II or Interim Wellhead Protection Area
    - is near or to other critical areas
    - is within soils with a rapid infiltration rate (greater than 2.4 inches per hour)
    - involves runoff from land uses with higher potential pollutant loads.
  - The Required Water Quality Volume is reduced through use of the LID site Design Credits.
  - Calculations documenting that the treatment train meets the 80% TSS removal requirement and, if applicable, the 44% TSS removal pretreatment requirement, are provided.



# Checklist for Stormwater Report

---

## Checklist (continued)

### Standard 4: Water Quality (continued)

- The BMP is sized (and calculations provided) based on:
  - The ½" or 1" Water Quality Volume or
  - The equivalent flow rate associated with the Water Quality Volume and documentation is provided showing that the BMP treats the required water quality volume.
- The applicant proposes to use proprietary BMPs, and documentation supporting use of proprietary BMP and proposed TSS removal rate is provided. This documentation may be in the form of the propriety BMP checklist found in Volume 2, Chapter 4 of the Massachusetts Stormwater Handbook and submitting copies of the TARP Report, STEP Report, and/or other third party studies verifying performance of the proprietary BMPs.
- A TMDL exists that indicates a need to reduce pollutants other than TSS and documentation showing that the BMPs selected are consistent with the TMDL is provided.

### Standard 5: Land Uses With Higher Potential Pollutant Loads (LUHPPLs)

- The NPDES Multi-Sector General Permit covers the land use and the Stormwater Pollution Prevention Plan (SWPPP) has been included with the Stormwater Report.
- The NPDES Multi-Sector General Permit covers the land use and the SWPPP will be submitted **prior to** the discharge of stormwater to the post-construction stormwater BMPs.
- The NPDES Multi-Sector General Permit does **not** cover the land use.
- LUHPPLs are located at the site and industry specific source control and pollution prevention measures have been proposed to reduce or eliminate the exposure of LUHPPLs to rain, snow, snow melt and runoff, and been included in the long term Pollution Prevention Plan.
- All exposure has been eliminated.
- All exposure has **not** been eliminated and all BMPs selected are on MassDEP LUHPPL list.
- The LUHPPL has the potential to generate runoff with moderate to higher concentrations of oil and grease (e.g. all parking lots with >1000 vehicle trips per day) and the treatment train includes an oil grit separator, a filtering bioretention area, a sand filter or equivalent.

### Standard 6: Critical Areas

- The discharge is near or to a critical area and the treatment train includes only BMPs that MassDEP has approved for stormwater discharges to or near that particular class of critical area.
- Critical areas and BMPs are identified in the Stormwater Report.



# Checklist for Stormwater Report

## Checklist (continued)

### Standard 7: Redevelopments and Other Projects Subject to the Standards only to the maximum extent practicable

- The project is subject to the Stormwater Management Standards only to the maximum Extent Practicable as a:
- Limited Project
  - Small Residential Projects: 5-9 single family houses or 5-9 units in a multi-family development provided there is no discharge that may potentially affect a critical area.
  - Small Residential Projects: 2-4 single family houses or 2-4 units in a multi-family development with a discharge to a critical area
  - Marina and/or boatyard provided the hull painting, service and maintenance areas are protected from exposure to rain, snow, snow melt and runoff
  - Bike Path and/or Foot Path
  - Redevelopment Project
  - Redevelopment portion of mix of new and redevelopment.
- Certain standards are not fully met (Standard No. 1, 8, 9, and 10 must always be fully met) and an explanation of why these standards are not met is contained in the Stormwater Report.
- The project involves redevelopment and a description of all measures that have been taken to improve existing conditions is provided in the Stormwater Report. The redevelopment checklist found in Volume 2 Chapter 3 of the Massachusetts Stormwater Handbook may be used to document that the proposed stormwater management system (a) complies with Standards 2, 3 and the pretreatment and structural BMP requirements of Standards 4-6 to the maximum extent practicable and (b) improves existing conditions.

### Standard 8: Construction Period Pollution Prevention and Erosion and Sedimentation Control

A Construction Period Pollution Prevention and Erosion and Sedimentation Control Plan must include the following information:

- Narrative;
  - Construction Period Operation and Maintenance Plan;
  - Names of Persons or Entity Responsible for Plan Compliance;
  - Construction Period Pollution Prevention Measures;
  - Erosion and Sedimentation Control Plan Drawings;
  - Detail drawings and specifications for erosion control BMPs, including sizing calculations;
  - Vegetation Planning;
  - Site Development Plan;
  - Construction Sequencing Plan;
  - Sequencing of Erosion and Sedimentation Controls;
  - Operation and Maintenance of Erosion and Sedimentation Controls;
  - Inspection Schedule;
  - Maintenance Schedule;
  - Inspection and Maintenance Log Form.
- A Construction Period Pollution Prevention and Erosion and Sedimentation Control Plan containing the information set forth above has been included in the Stormwater Report.



# Checklist for Stormwater Report

---

## Checklist (continued)

### Standard 8: Construction Period Pollution Prevention and Erosion and Sedimentation Control (continued)

- The project is highly complex and information is included in the Stormwater Report that explains why it is not possible to submit the Construction Period Pollution Prevention and Erosion and Sedimentation Control Plan with the application. A Construction Period Pollution Prevention and Erosion and Sedimentation Control has **not** been included in the Stormwater Report but will be submitted **before** land disturbance begins.
- The project is **not** covered by a NPDES Construction General Permit.
- The project is covered by a NPDES Construction General Permit and a copy of the SWPPP is in the Stormwater Report.
- The project is covered by a NPDES Construction General Permit but no SWPPP been submitted. The SWPPP will be submitted BEFORE land disturbance begins.

### Standard 9: Operation and Maintenance Plan

- The Post Construction Operation and Maintenance Plan is included in the Stormwater Report and includes the following information:
  - Name of the stormwater management system owners;
  - Party responsible for operation and maintenance;
  - Schedule for implementation of routine and non-routine maintenance tasks;
  - Plan showing the location of all stormwater BMPs maintenance access areas;
  - Description and delineation of public safety features;
  - Estimated operation and maintenance budget; and
  - Operation and Maintenance Log Form.
- The responsible party is **not** the owner of the parcel where the BMP is located and the Stormwater Report includes the following submissions:
  - A copy of the legal instrument (deed, homeowner's association, utility trust or other legal entity) that establishes the terms of and legal responsibility for the operation and maintenance of the project site stormwater BMPs;
  - A plan and easement deed that allows site access for the legal entity to operate and maintain BMP functions.

### Standard 10: Prohibition of Illicit Discharges

- The Long-Term Pollution Prevention Plan includes measures to prevent illicit discharges;
- An Illicit Discharge Compliance Statement is attached;
- NO Illicit Discharge Compliance Statement is attached but will be submitted **prior to** the discharge of any stormwater to post-construction BMPs.

## **APPENDIX B: PROJECT LOCATION MAPS**

- USGS MAP
- FEMA FIRMETTE

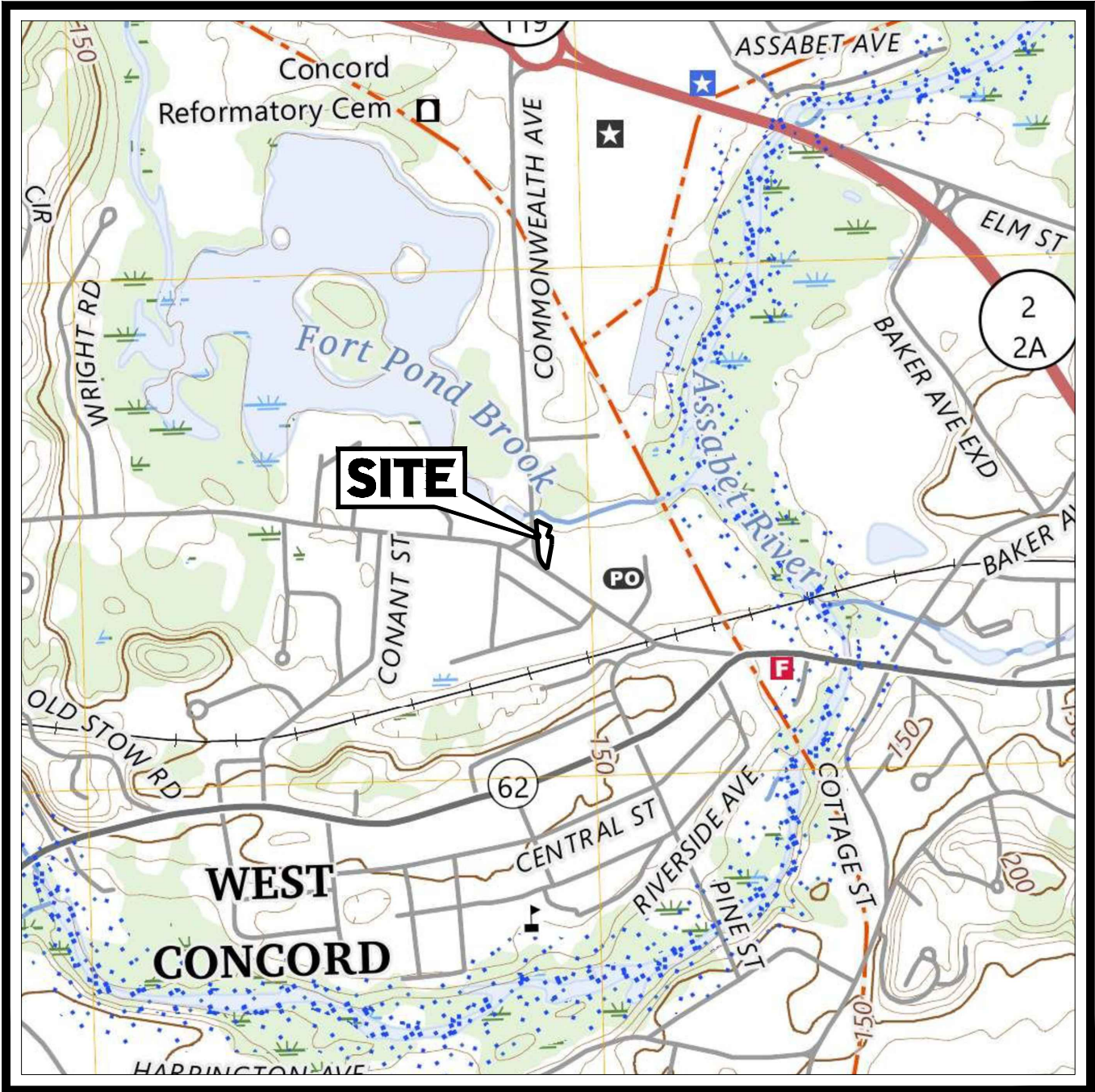

**USGS MAP**

SCALE: 1" = 1,000'

SOURCE: USGS MAYNARD QUADRANGLE

# National Flood Hazard Layer FIRMMette



71°24'8"W 42°27'44"N

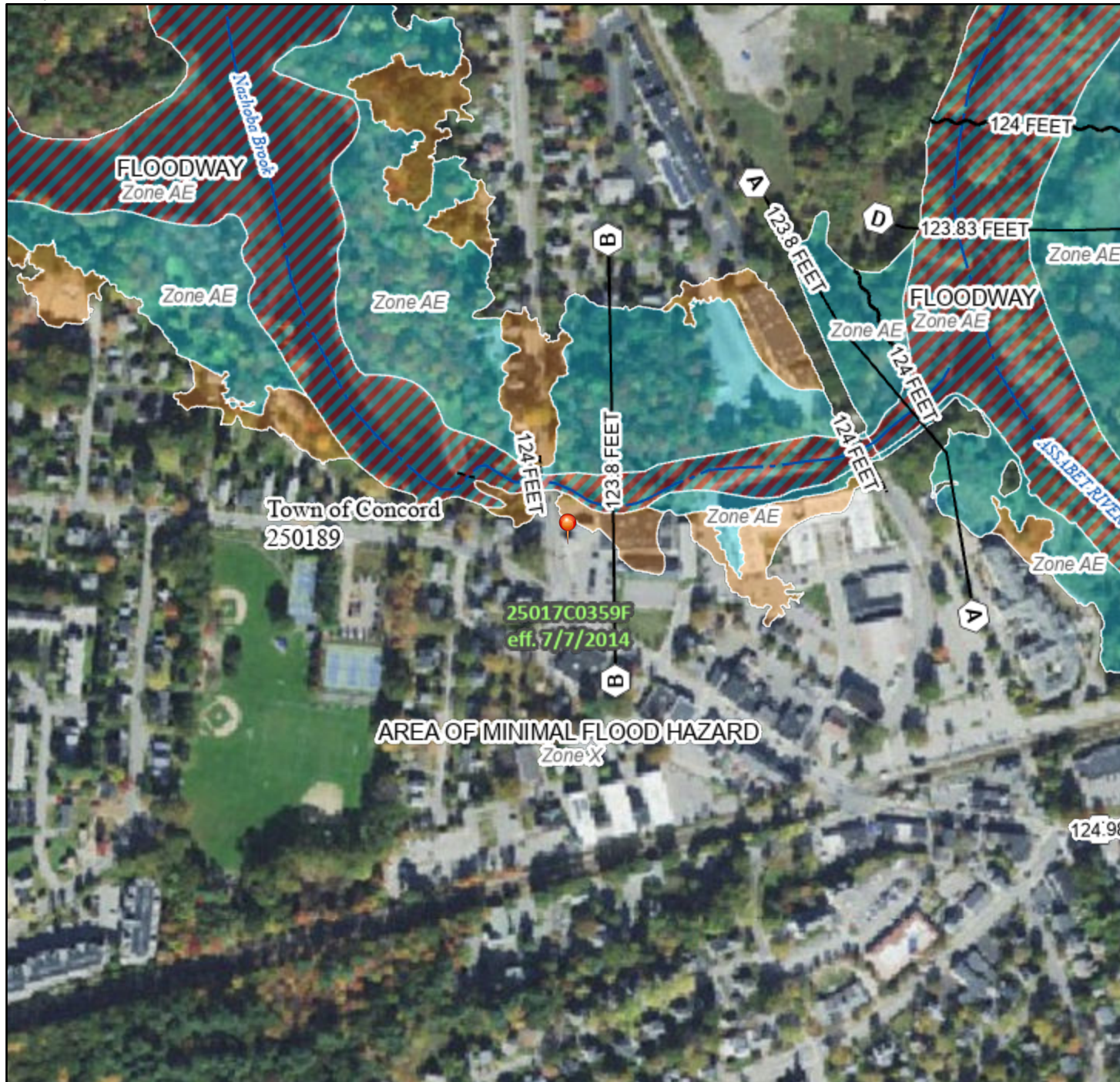

## Legend

SEE FIS REPORT FOR DETAILED LEGEND AND INDEX MAP FOR FIRM PANEL LAYOUT

SPECIAL FLOOD HAZARD AREAS		Without Base Flood Elevation (BFE) <i>Zone A, V, A99</i>
		With BFE or Depth <i>Zone AE, AO, AH, VE, AR</i>
		Regulatory Floodway

OTHER AREAS OF FLOOD HAZARD		0.2% Annual Chance Flood Hazard, Areas of 1% annual chance flood with average depth less than one foot or with drainage areas of less than one square mile <i>Zone X</i>
		Future Conditions 1% Annual Chance Flood Hazard <i>Zone X</i>
		Area with Reduced Flood Risk due to Levee. See Notes. <i>Zone X</i>
		Area with Flood Risk due to Levee <i>Zone D</i>

OTHER AREAS		NO SCREEN Area of Minimal Flood Hazard <i>Zone X</i>
		Effective LOMRs
GENERAL STRUCTURES		Area of Undetermined Flood Hazard <i>Zone D</i>
		Channel, Culvert, or Storm Sewer
		Levee, Dike, or Floodwall

OTHER FEATURES		20.2 Cross Sections with 1% Annual Chance Water Surface Elevation
		17.5 Cross Sections with 1% Annual Chance Water Surface Elevation
		Coastal Transect
		Base Flood Elevation Line (BFE)
		Limit of Study
		Jurisdiction Boundary
		Coastal Transect Baseline
		Profile Baseline
		Hydrographic Feature

MAP PANELS		Digital Data Available
		No Digital Data Available
		Unmapped
		The pin displayed on the map is an approximate point selected by the user and does not represent an authoritative property location.

This map complies with FEMA's standards for the use of digital flood maps if it is not void as described below. The basemap shown complies with FEMA's basemap accuracy standards

The flood hazard information is derived directly from the authoritative NFHL web services provided by FEMA. This map was exported on **11/18/2025 at 6:27 PM** and does not reflect changes or amendments subsequent to this date and time. The NFHL and effective information may change or become superseded by new data over time.

This map image is void if the one or more of the following map elements do not appear: basemap imagery, flood zone labels, legend, scale bar, map creation date, community identifiers, FIRM panel number, and FIRM effective date. Map images for unmapped and unmodernized areas cannot be used for regulatory purposes.

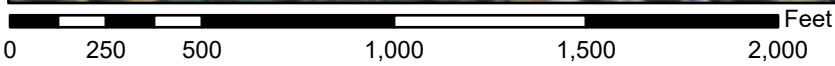

1:6,000

71°23'31"W 42°27'17"N

Basemap Imagery Source: USGS National Map 2023

**APPENDIX C: SOIL AND WETLAND INFORMATION**

- NCRS CUSTOM SOIL RESOURCE REPORT
- WETLAND BORDER REPORT

# Custom Soil Resource Report Soil Map

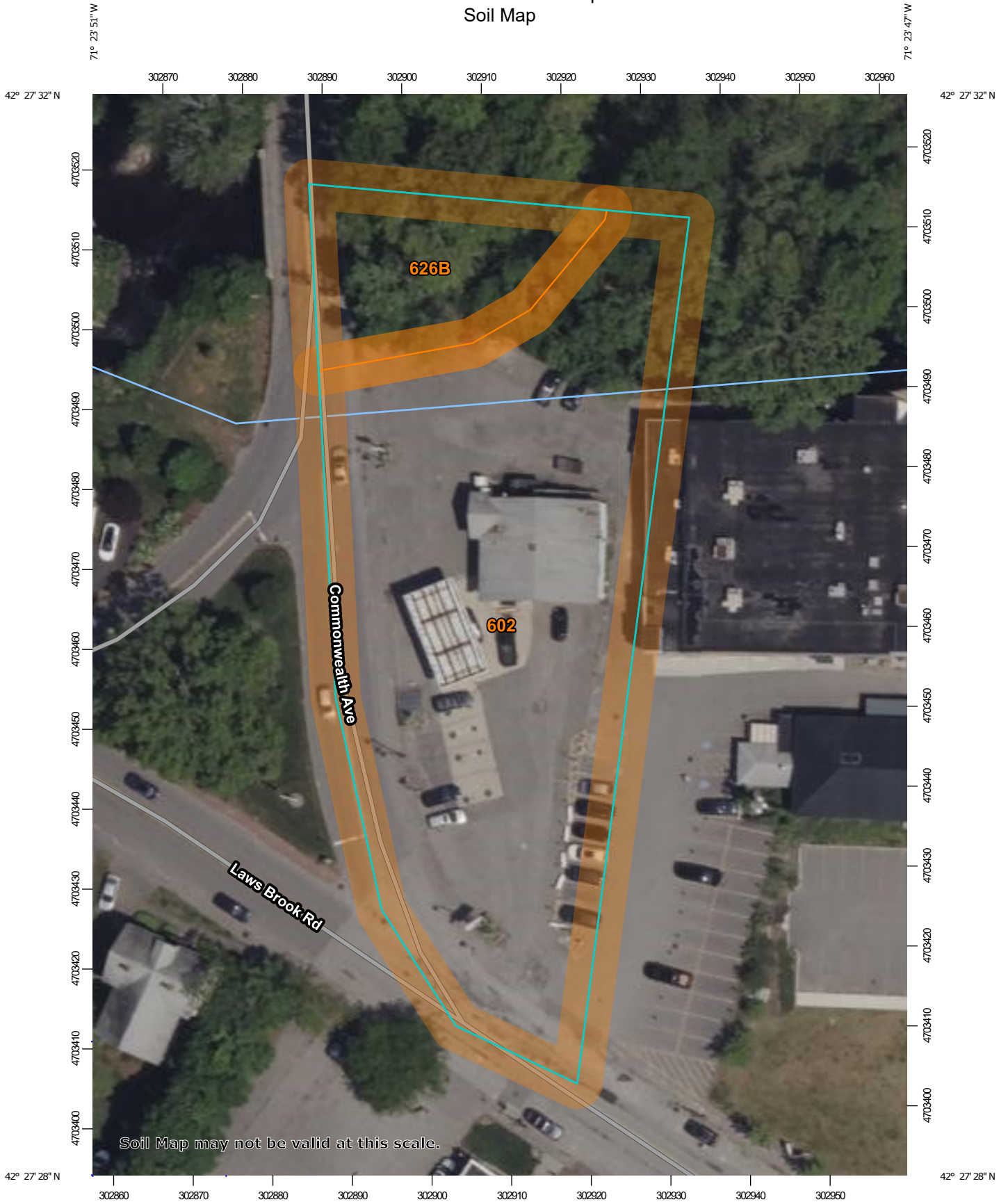

Map Scale: 1:659 if printed on A portrait (8.5" x 11") sheet.

0 5 10 20 30 Meters

0 30 60 120 180 Feet

Map projection: Web Mercator Corner coordinates: WGS84 Edge tics: UTM Zone 19N WGS84



### MAP LEGEND

**Area of Interest (AOI)**

 Area of Interest (AOI)



















**Soils**







 Soil Map Unit Polygons

 Soil Map Unit Lines

 Soil Map Unit Points

**Special Point Features**





-  Blowout
-  Borrow Pit
-  Clay Spot
-  Closed Depression
-  Gravel Pit
-  Gravelly Spot
-  Landfill
-  Lava Flow
-  Marsh or swamp
-  Mine or Quarry
-  Miscellaneous Water
-  Perennial Water
-  Rock Outcrop
-  Saline Spot
-  Sandy Spot
-  Severely Eroded Spot
-  Sinkhole
-  Slide or Slip
-  Sodic Spot

-  Spoil Area
-  Stony Spot
-  Very Stony Spot
-  Wet Spot
-  Other
-  Special Line Features

**Water Features**

 Streams and Canals

**Transportation**

-  Rails
-  Interstate Highways
-  US Routes
-  Major Roads
-  Local Roads

**Background**

 Aerial Photography

### MAP INFORMATION

The soil surveys that comprise your AOI were mapped at 1:24,000.

Warning: Soil Map may not be valid at this scale.

Enlargement of maps beyond the scale of mapping can cause misunderstanding of the detail of mapping and accuracy of soil line placement. The maps do not show the small areas of contrasting soils that could have been shown at a more detailed scale.

Please rely on the bar scale on each map sheet for map measurements.

Source of Map: Natural Resources Conservation Service  
 Web Soil Survey URL:  
 Coordinate System: Web Mercator (EPSG:3857)

Maps from the Web Soil Survey are based on the Web Mercator projection, which preserves direction and shape but distorts distance and area. A projection that preserves area, such as the Albers equal-area conic projection, should be used if more accurate calculations of distance or area are required.

This product is generated from the USDA-NRCS certified data as of the version date(s) listed below.

Soil Survey Area: Middlesex County, Massachusetts  
 Survey Area Data: Version 25, Sep 5, 2025

Soil map units are labeled (as space allows) for map scales 1:50,000 or larger.

Date(s) aerial images were photographed: May 22, 2022—Jun 5, 2022

The orthophoto or other base map on which the soil lines were compiled and digitized probably differs from the background imagery displayed on these maps. As a result, some minor shifting of map unit boundaries may be evident.

## Map Unit Legend

Map Unit Symbol	Map Unit Name	Acres in AOI	Percent of AOI
602	Urban land	0.8	84.5%
626B	Merrimac-Urban land complex, 0 to 8 percent slopes	0.1	15.5%
<b>Totals for Area of Interest</b>		<b>1.0</b>	<b>100.0%</b>

## Map Unit Descriptions

The map units delineated on the detailed soil maps in a soil survey represent the soils or miscellaneous areas in the survey area. The map unit descriptions, along with the maps, can be used to determine the composition and properties of a unit.

A map unit delineation on a soil map represents an area dominated by one or more major kinds of soil or miscellaneous areas. A map unit is identified and named according to the taxonomic classification of the dominant soils. Within a taxonomic class there are precisely defined limits for the properties of the soils. On the landscape, however, the soils are natural phenomena, and they have the characteristic variability of all natural phenomena. Thus, the range of some observed properties may extend beyond the limits defined for a taxonomic class. Areas of soils of a single taxonomic class rarely, if ever, can be mapped without including areas of other taxonomic classes. Consequently, every map unit is made up of the soils or miscellaneous areas for which it is named and some minor components that belong to taxonomic classes other than those of the major soils.

Most minor soils have properties similar to those of the dominant soil or soils in the map unit, and thus they do not affect use and management. These are called noncontrasting, or similar, components. They may or may not be mentioned in a particular map unit description. Other minor components, however, have properties and behavioral characteristics divergent enough to affect use or to require different management. These are called contrasting, or dissimilar, components. They generally are in small areas and could not be mapped separately because of the scale used. Some small areas of strongly contrasting soils or miscellaneous areas are identified by a special symbol on the maps. If included in the database for a given area, the contrasting minor components are identified in the map unit descriptions along with some characteristics of each. A few areas of minor components may not have been observed, and consequently they are not mentioned in the descriptions, especially where the pattern was so complex that it was impractical to make enough observations to identify all the soils and miscellaneous areas on the landscape.

The presence of minor components in a map unit in no way diminishes the usefulness or accuracy of the data. The objective of mapping is not to delineate pure taxonomic classes but rather to separate the landscape into landforms or landform segments that have similar use and management requirements. The delineation of such segments on the map provides sufficient information for the development of resource plans. If intensive use of small areas is planned, however,

## Custom Soil Resource Report

onsite investigation is needed to define and locate the soils and miscellaneous areas.

An identifying symbol precedes the map unit name in the map unit descriptions. Each description includes general facts about the unit and gives important soil properties and qualities.

Soils that have profiles that are almost alike make up a *soil series*. Except for differences in texture of the surface layer, all the soils of a series have major horizons that are similar in composition, thickness, and arrangement.

Soils of one series can differ in texture of the surface layer, slope, stoniness, salinity, degree of erosion, and other characteristics that affect their use. On the basis of such differences, a soil series is divided into *soil phases*. Most of the areas shown on the detailed soil maps are phases of soil series. The name of a soil phase commonly indicates a feature that affects use or management. For example, Alpha silt loam, 0 to 2 percent slopes, is a phase of the Alpha series.

Some map units are made up of two or more major soils or miscellaneous areas. These map units are complexes, associations, or undifferentiated groups.

A *complex* consists of two or more soils or miscellaneous areas in such an intricate pattern or in such small areas that they cannot be shown separately on the maps. The pattern and proportion of the soils or miscellaneous areas are somewhat similar in all areas. Alpha-Beta complex, 0 to 6 percent slopes, is an example.

An *association* is made up of two or more geographically associated soils or miscellaneous areas that are shown as one unit on the maps. Because of present or anticipated uses of the map units in the survey area, it was not considered practical or necessary to map the soils or miscellaneous areas separately. The pattern and relative proportion of the soils or miscellaneous areas are somewhat similar. Alpha-Beta association, 0 to 2 percent slopes, is an example.

An *undifferentiated group* is made up of two or more soils or miscellaneous areas that could be mapped individually but are mapped as one unit because similar interpretations can be made for use and management. The pattern and proportion of the soils or miscellaneous areas in a mapped area are not uniform. An area can be made up of only one of the major soils or miscellaneous areas, or it can be made up of all of them. Alpha and Beta soils, 0 to 2 percent slopes, is an example.

Some surveys include *miscellaneous areas*. Such areas have little or no soil material and support little or no vegetation. Rock outcrop is an example.

## Middlesex County, Massachusetts

### 602—Urban land

#### Map Unit Setting

*National map unit symbol:* 9950  
*Elevation:* 0 to 3,000 feet  
*Mean annual precipitation:* 32 to 50 inches  
*Mean annual air temperature:* 45 to 50 degrees F  
*Frost-free period:* 110 to 200 days  
*Farmland classification:* Not prime farmland

#### Map Unit Composition

*Urban land:* 85 percent  
*Minor components:* 15 percent  
*Estimates are based on observations, descriptions, and transects of the mapunit.*

#### Description of Urban Land

##### Setting

*Landform position (two-dimensional):* Footslope  
*Landform position (three-dimensional):* Base slope  
*Down-slope shape:* Linear  
*Across-slope shape:* Linear  
*Parent material:* Excavated and filled land

#### Minor Components

##### Udorthents, wet substratum

*Percent of map unit:* 5 percent  
*Hydric soil rating:* No

##### Rock outcrop

*Percent of map unit:* 5 percent  
*Landform:* Ledges  
*Landform position (two-dimensional):* Summit  
*Landform position (three-dimensional):* Head slope  
*Down-slope shape:* Concave  
*Across-slope shape:* Concave

##### Udorthents, loamy

*Percent of map unit:* 5 percent  
*Hydric soil rating:* No

### 626B—Merrimac-Urban land complex, 0 to 8 percent slopes

#### Map Unit Setting

*National map unit symbol:* 2tyr9  
*Elevation:* 0 to 820 feet  
*Mean annual precipitation:* 36 to 71 inches

## Custom Soil Resource Report

*Mean annual air temperature:* 39 to 55 degrees F  
*Frost-free period:* 140 to 250 days  
*Farmland classification:* Not prime farmland

### Map Unit Composition

*Merrimac and similar soils:* 45 percent  
*Urban land:* 40 percent  
*Minor components:* 15 percent  
*Estimates are based on observations, descriptions, and transects of the mapunit.*

### Description of Merrimac

#### Setting

*Landform:* Moraines, outwash plains, outwash terraces, kames, eskers  
*Landform position (two-dimensional):* Summit, shoulder, backslope, footslope  
*Landform position (three-dimensional):* Side slope, crest, riser, tread  
*Down-slope shape:* Convex  
*Across-slope shape:* Convex  
*Parent material:* Loamy glaciofluvial deposits derived from granite, schist, and gneiss over sandy and gravelly glaciofluvial deposits derived from granite, schist, and gneiss

#### Typical profile

*Ap - 0 to 10 inches:* fine sandy loam  
*Bw1 - 10 to 22 inches:* fine sandy loam  
*Bw2 - 22 to 26 inches:* stratified gravel to gravelly loamy sand  
*2C - 26 to 65 inches:* stratified gravel to very gravelly sand

#### Properties and qualities

*Slope:* 0 to 8 percent  
*Depth to restrictive feature:* More than 80 inches  
*Drainage class:* Somewhat excessively drained  
*Runoff class:* Very low  
*Capacity of the most limiting layer to transmit water (Ksat):* Moderately high to very high (1.42 to 99.90 in/hr)  
*Depth to water table:* More than 80 inches  
*Frequency of flooding:* None  
*Frequency of ponding:* None  
*Calcium carbonate, maximum content:* 2 percent  
*Maximum salinity:* Nonsaline (0.0 to 1.4 mmhos/cm)  
*Sodium adsorption ratio, maximum:* 1.0  
*Available water supply, 0 to 60 inches:* Low (about 4.6 inches)

#### Interpretive groups

*Land capability classification (irrigated):* None specified  
*Land capability classification (nonirrigated):* 2e  
*Hydrologic Soil Group:* A  
*Ecological site:* F144AY022MA - Dry Outwash  
*Hydric soil rating:* No

### Description of Urban Land

#### Typical profile

*M - 0 to 10 inches:* cemented material

#### Properties and qualities

*Slope:* 0 to 8 percent

## Custom Soil Resource Report

*Depth to restrictive feature:* 0 inches to manufactured layer

*Runoff class:* Very high

*Capacity of the most limiting layer to transmit water (Ksat):* Very low (0.00 to 0.00 in/hr)

*Available water supply, 0 to 60 inches:* Very low (about 0.0 inches)

### Interpretive groups

*Land capability classification (irrigated):* None specified

*Land capability classification (nonirrigated):* 8

*Hydrologic Soil Group:* D

*Hydric soil rating:* Unranked

### Minor Components

#### Windsor

*Percent of map unit:* 5 percent

*Landform:* Dunes, outwash plains, outwash terraces, deltas

*Landform position (three-dimensional):* Tread, riser

*Down-slope shape:* Convex, linear

*Across-slope shape:* Convex, linear

*Hydric soil rating:* No

#### Sudbury

*Percent of map unit:* 5 percent

*Landform:* Terraces, outwash plains, deltas

*Landform position (two-dimensional):* Footslope

*Landform position (three-dimensional):* Tread, dip

*Down-slope shape:* Concave

*Across-slope shape:* Linear

*Hydric soil rating:* No

#### Hinckley

*Percent of map unit:* 5 percent

*Landform:* Outwash plains, kames, eskers, deltas

*Landform position (two-dimensional):* Summit, shoulder, backslope

*Landform position (three-dimensional):* Head slope, nose slope, side slope, crest, rise

*Down-slope shape:* Convex

*Across-slope shape:* Linear, convex

*Hydric soil rating:* No

Hydrologic Soil Group—Middlesex County, Massachusetts

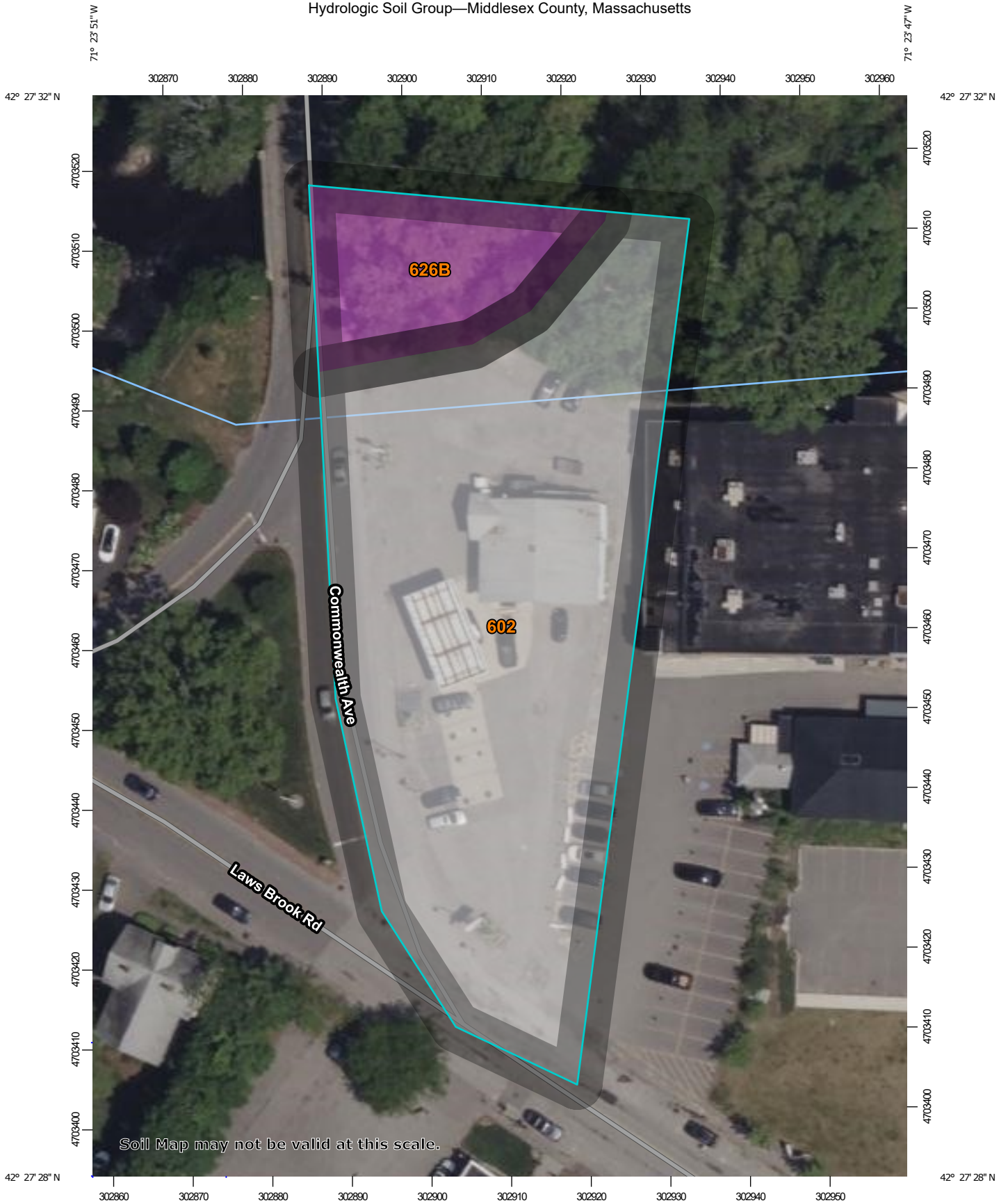

Soil Map may not be valid at this scale.

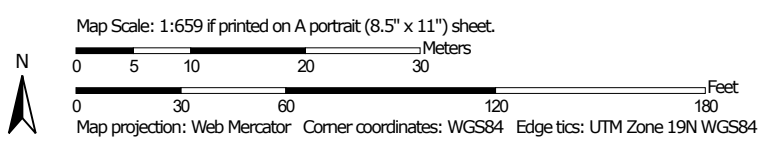

## MAP LEGEND

### Area of Interest (AOI)









 Area of Interest (AOI)

### Soils

#### Soil Rating Polygons





 A  
 A/D  
 B  
 B/D  
 C  
 C/D  
 D  
 Not rated or not available

#### Soil Rating Lines

 A  
 A/D  
 B  
 B/D  
 C  
 C/D  
 D  
 Not rated or not available

#### Soil Rating Points





 A  
 A/D  
 B  
 B/D

 C  
 C/D  
 D  
 Not rated or not available

### Water Features

 Streams and Canals

### Transportation

 Rails  
 Interstate Highways  
 US Routes  
 Major Roads  
 Local Roads

### Background

 Aerial Photography

## MAP INFORMATION

The soil surveys that comprise your AOI were mapped at 1:24,000.

Warning: Soil Map may not be valid at this scale.

Enlargement of maps beyond the scale of mapping can cause misunderstanding of the detail of mapping and accuracy of soil line placement. The maps do not show the small areas of contrasting soils that could have been shown at a more detailed scale.

Please rely on the bar scale on each map sheet for map measurements.

Source of Map: Natural Resources Conservation Service  
 Web Soil Survey URL:  
 Coordinate System: Web Mercator (EPSG:3857)

Maps from the Web Soil Survey are based on the Web Mercator projection, which preserves direction and shape but distorts distance and area. A projection that preserves area, such as the Albers equal-area conic projection, should be used if more accurate calculations of distance or area are required.

This product is generated from the USDA-NRCS certified data as of the version date(s) listed below.

Soil Survey Area: Middlesex County, Massachusetts  
 Survey Area Data: Version 25, Sep 5, 2025

Soil map units are labeled (as space allows) for map scales 1:50,000 or larger.

Date(s) aerial images were photographed: May 22, 2022—Jun 5, 2022

The orthophoto or other base map on which the soil lines were compiled and digitized probably differs from the background imagery displayed on these maps. As a result, some minor shifting of map unit boundaries may be evident.

## Hydrologic Soil Group

Map unit symbol	Map unit name	Rating	Acres in AOI	Percent of AOI
602	Urban land		0.8	84.5%
626B	Merrimac-Urban land complex, 0 to 8 percent slopes	A	0.1	15.5%
<b>Totals for Area of Interest</b>			<b>1.0</b>	<b>100.0%</b>

### Description

Hydrologic soil groups are based on estimates of runoff potential. Soils are assigned to one of four groups according to the rate of water infiltration when the soils are not protected by vegetation, are thoroughly wet, and receive precipitation from long-duration storms.

The soils in the United States are assigned to four groups (A, B, C, and D) and three dual classes (A/D, B/D, and C/D). The groups are defined as follows:

Group A. Soils having a high infiltration rate (low runoff potential) when thoroughly wet. These consist mainly of deep, well drained to excessively drained sands or gravelly sands. These soils have a high rate of water transmission.

Group B. Soils having a moderate infiltration rate when thoroughly wet. These consist chiefly of moderately deep or deep, moderately well drained or well drained soils that have moderately fine texture to moderately coarse texture. These soils have a moderate rate of water transmission.

Group C. Soils having a slow infiltration rate when thoroughly wet. These consist chiefly of soils having a layer that impedes the downward movement of water or soils of moderately fine texture or fine texture. These soils have a slow rate of water transmission.

Group D. Soils having a very slow infiltration rate (high runoff potential) when thoroughly wet. These consist chiefly of clays that have a high shrink-swell potential, soils that have a high water table, soils that have a claypan or clay layer at or near the surface, and soils that are shallow over nearly impervious material. These soils have a very slow rate of water transmission.

If a soil is assigned to a dual hydrologic group (A/D, B/D, or C/D), the first letter is for drained areas and the second is for undrained areas. Only the soils that in their natural condition are in group D are assigned to dual classes.

### Rating Options

*Aggregation Method:* Dominant Condition

*Component Percent Cutoff: None Specified*

*Tie-break Rule: Higher*

## Wetland Border Report

Site Locus: 166 Commonwealth Avenue, Concord, MA 01742

Prepared for: Concord Country Store LLC

Prepared by: Goddard Consulting LLC, 291 Main St, Suite 8, Northborough, MA 01532

Date: 03/11/2025

### INTRODUCTION

On March 7, 2025, wetland resources were delineated for Concord Country Store LLC on land located on or near 166 Commonwealth Avenue in Concord, MA (refer to enclosed locus maps). The wetland border was flagged using the criteria in the most recent edition of the Massachusetts Wetlands Protection Act (WPA) and Regulations (310 CMR 10.00) and the Concord Wetlands Bylaw & Regulations (Article 58 & 59). Hydric soil indicators, vegetation changes, hydrological indicators, and topography were all considered for delineation purposes.

The titles of attached documents are as follows:

- USGS of Locus Site, Goddard Consulting LLC, 1/23/2025
- Orthophoto of Locus Site, Goddard Consulting LLC, 1/23/2025
- FEMA Flood Map of Locus Site, Goddard Consulting LLC, 1/23/2025
- NRCS Soil Survey of Locus Site, Goddard Consulting LLC, 1/23/2025

### SUMMARY OF FINDINGS

The northern boundary of the locus site is bordered by a perennial stream known as Nashoba Brook. The stream flows east from a dam before flowing under Commonwealth Avenue onto the locus site. Bordering Vegetated Wetland exists north of Nashoba Brook off the locus site. The southern Mean Annual High-Water (MAHW) line of the stream is primarily armored by a large rock wall. The southern Mean Annual High-Water line of Nashoba Brook was delineated with flag series GC MAHW1 – GC MAHW7 and GC MAHWB1 – GC MAHWB3.

According to the MassGIS data layers for the Natural Heritage & Endangered Species Program (NHESP), the locus site is not located within Estimated and/or Priority Habitat of Rare Wildlife or an Area of Critical Environmental Concern (ACEC). The site is not located in an Outstanding Resource Waters Area (ORW). The site does fall within a jurisdictional FEMA Flood Zone known as a “Regulatory Floodway” and a non-jurisdictional “Zone X: 0.2% Annual Chance Flood Hazard”. There are no mapped certified or potential vernal pools on site.

The MA Wetlands Protection Act and the Town of Concord take jurisdiction over perennial streams and their associated Riverfront Area. Any work within these resource areas, including the 200-foot Riverfront Area, requires a Request for Determination (RDA) or Notice of Intent (NOI) to be filed with the Concord Conservation Commission.

### DESCRIPTION OF REGULATED INLAND RESOURCE AREA

The table below provides the regulatory jurisdiction, flag numbers/colors, and wetland types and locations for the resource areas delineated.

Resource Area	Regulatory Jurisdiction	Flag Numbers and Color	Wetland Types and Locations
Perennial Stream (Nashoba Brook)	200-foot Riverfront Area	GC MAHW1- GC MAHW7 (Pink flags)	Southern Mean Annual High-Water line of Nashoba Brook (East of Commonwealth Ave)

Perennial Stream (Nashoba Brook)	200-foot Riverfront Area	GC MAHWB1- GC MAHWB3 (Pink flags)	Southern Mean Annual High-Water line of Nashoba Brook (West of Commonwealth Ave)
-------------------------------------	-----------------------------	---	---

**SITE PHOTOS**



**Photo 1.** View Nashoba Brook facing east at the northeastern corner of the locus site.



**Photo 2.** View of Nashoba Brook facing east at northwestern corner of the locus site.



**Photo 3.** View of Nashoba Brook facing the locus site.



**Photo 4.** View of Nashoba Brook west of the locus site.

Please don't hesitate to reach out to our office with questions or concerns.

Sincerely,

Goddard Consulting, LLC



Tom Schutz, WPIT, WSA  
**Wetland Scientist**



Kristina McEvoy  
**Wetland Scientist**

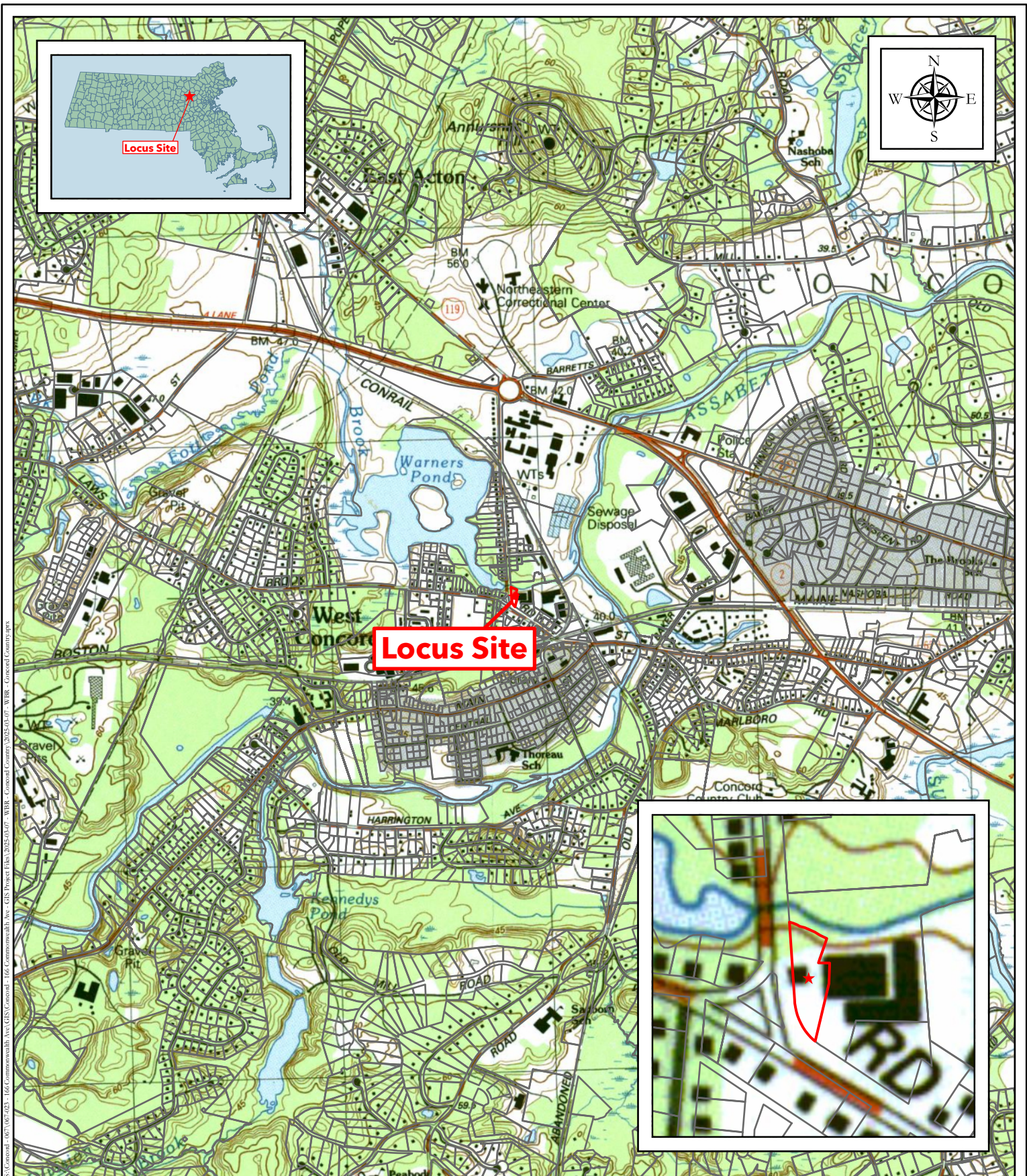

S:\Concord - 0671067103 - 166 Commonwealth Ave GIS\Concord - 166 Commonwealth Ave GIS Project Files\2025-03-07 - WBR - Concord\Concord\_2025-03-07 - WBR - Concord\Concord.mxd



### USGS of Locus Site

0 1,000 2,000 Feet 1" = 2,000'

71.397022°W, 42.4584588°N



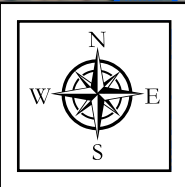
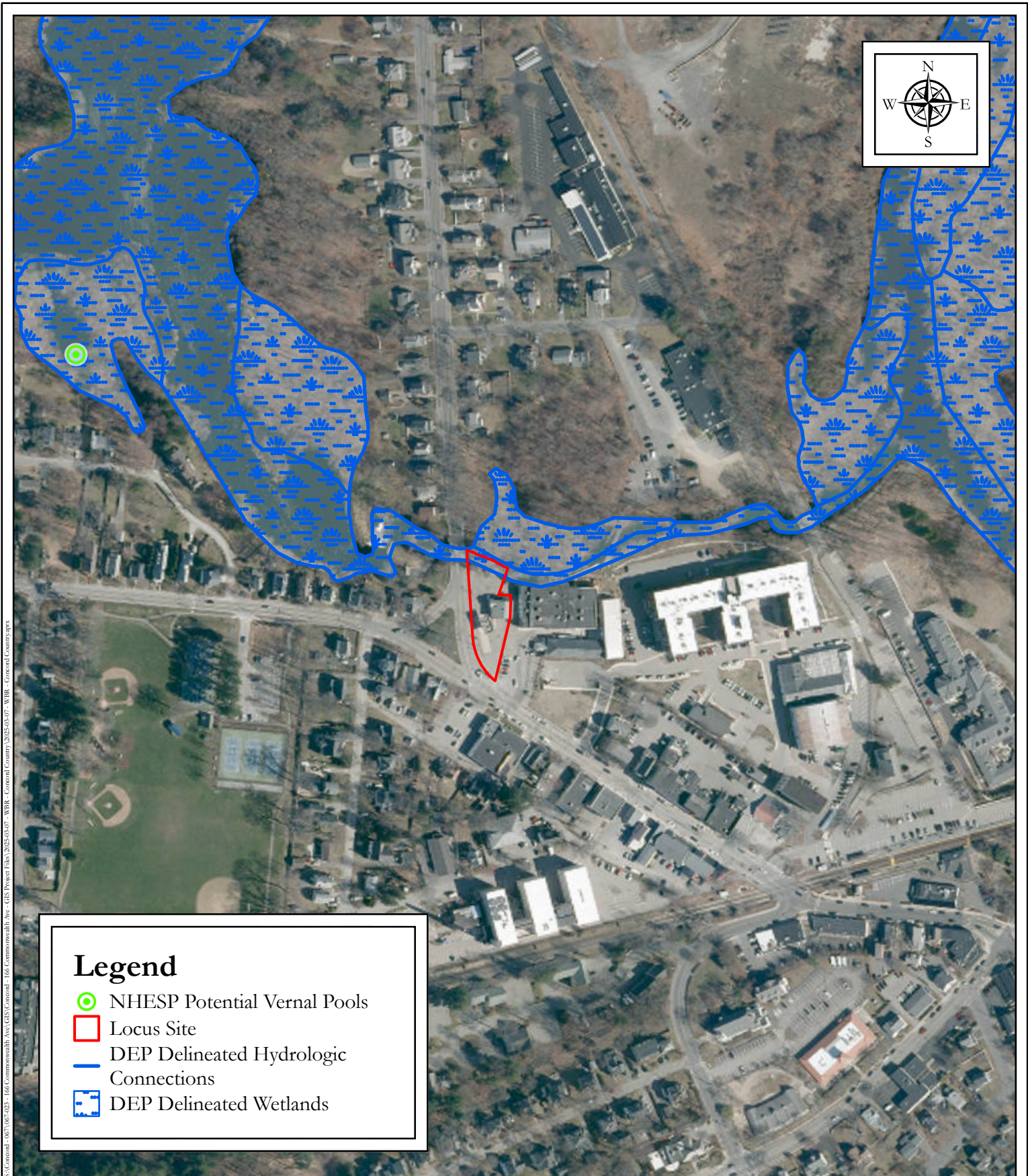

Date: 03/07/2025

166 Commonwealth Avenue  
Concord, MA 01742

Parcel ID: 2184-2



**Legend**

-  NHESP Potential Vernal Pools
-  Locus Site
-  DEP Delineated Hydrologic Connections
-  DEP Delineated Wetlands

S:\Concord - 007\007-023 - 166 Commonwealth Ave GIS\Concord - 166 Commonwealth Ave GIS Project Files\2025-03-07 - WBR - Concord County\2025-03-07 - WBR - Concord County.aprx



Orthophoto of Locus Site

0 150 300 Feet 1" = 300'

71.3967996°W, 42.458582°N

Date: 03/07/2025

166 Commonwealth Avenue  
Concord, MA 01742

Parcel ID: 2184-2

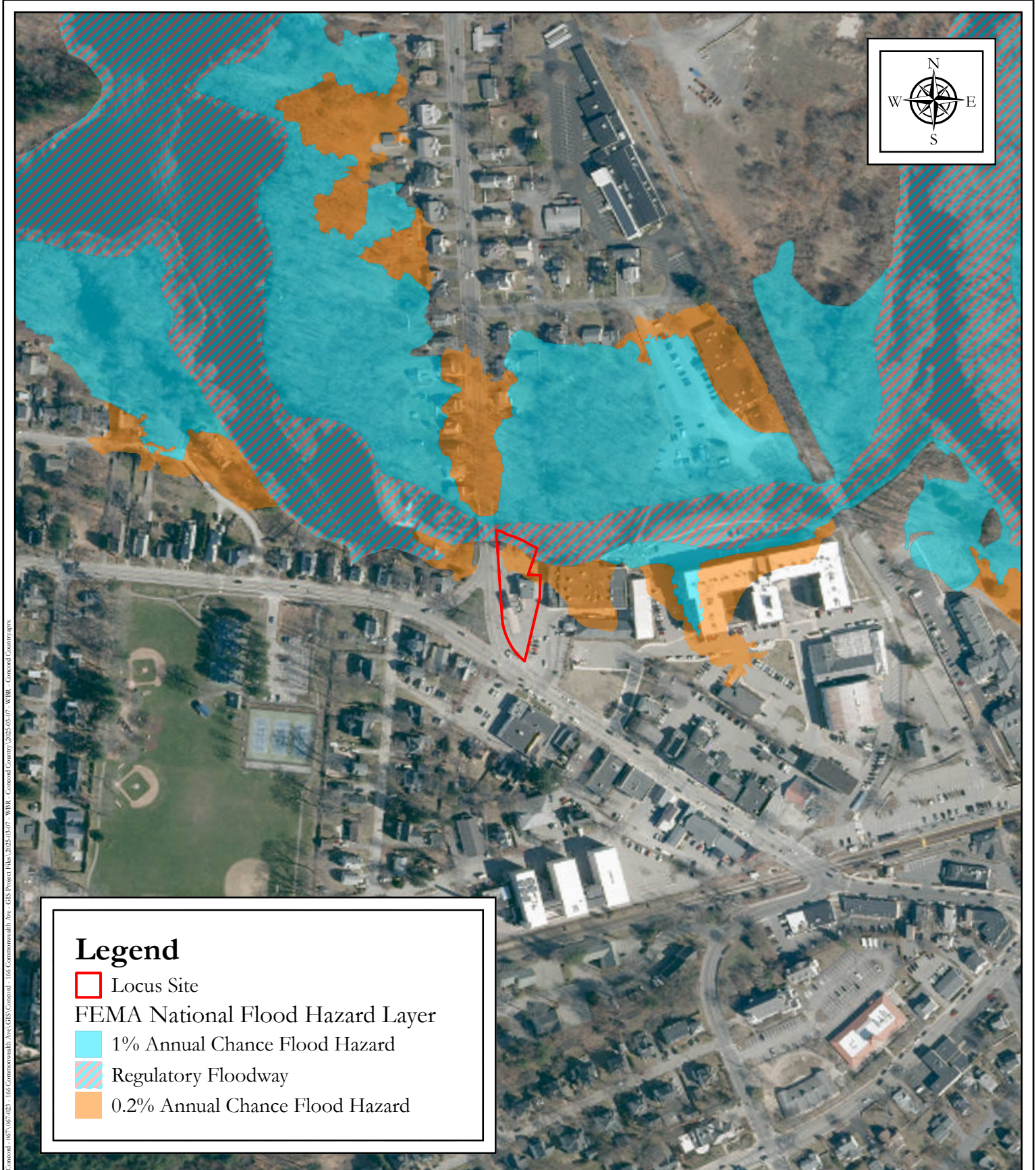

**Legend**

- Locus Site
- FEMA National Flood Hazard Layer
  - 1% Annual Chance Flood Hazard
  - Regulatory Floodway
  - 0.2% Annual Chance Flood Hazard

S:\Concord - 067\067-023 - 166 Commonwealth Ave GIS\Concord - 166 Commonwealth Ave GIS Project Files\2025-03-07 - WBR - Concord County\2025-03-07 - WBR - Concord County.aprx



## FEMA Flood Map of Locus Site



71.397022°W, 42.4584588°N

Date: 03/07/2025

166 Commonwealth Avenue  
Concord, MA 01742

Parcel ID: 2184-2



S:\Concord - 067\067-023 - 166 Commonwealth Ave GIS\Concord - 166 Commonwealth Ave GIS Project Files\2025-03-07 - WBR - Concord County\2025-03-07 - WBR - Concord County.aprx



## NRCS Soil Survey of Locus Site

0 60 120 1" = 120'  
Feet

71.397022°W, 42.4584588°N

Date: 03/07/2025

166 Commonwealth Avenue  
Concord, MA 01742

Parcel ID: 2184-2

**APPENDIX D: EXISTING CONDITIONS HYDROLOGIC ANALYSIS**

- EXISTING CONDITIONS DRAINAGE MAP
- EXISTING CONDITIONS HYDROCAD COMPUTATIONS

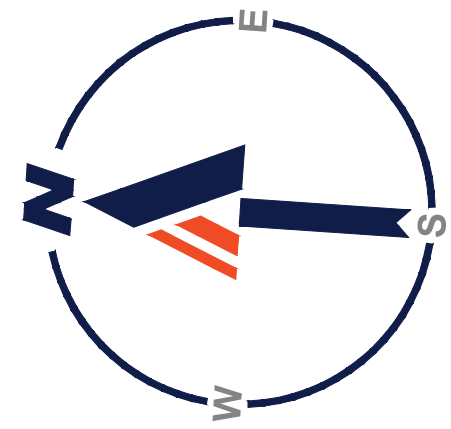

LEGEND	
EXISTING WATERSHED	
DESIGN POINT	
SUBCATCHMENT ID	
SUBCATCHMENT BOUNDARY	
TIME OF CONCENTRATION PATH	
SOIL BOUNDARY WITH NRCS MAP UNIT AND HYDROLOGIC SOIL GROUP RATING	

**BOHLER**  
 SITE CIVIL AND CONSULTING ENGINEERING  
 PROGRAM MANAGEMENT  
 LANDSCAPE ARCHITECTURE  
 SUSTAINABLE DESIGN  
 PERMITTING SERVICES  
 TRANSPORTATION SERVICES

REVISIONS				
REV	DATE	COMMENT	DRAWN BY	CHECKED BY

**811**  
 Know what's below.  
 Call before you dig.  
 ALWAYS CALL 811  
 It's fast. It's free. It's the law.

**ISSUED FOR ENTITLEMENTS**

PROJECT No.: MAA250062.00-0B  
 DRAWN BY: JDG  
 CHECKED BY: CSE  
 DATE: 11/06/2025  
 CAD ID: P-DMAP-HYDR

**PROPOSED SITE PLAN DOCUMENTS**  
 FOR  
**ROUTE 85 REALTY CORP.**  
 PROPOSED RETAIL STORE AND AUTO SERVICE STATION  
 166 COMMONWEALTH AVENUE  
 MIDDLESEX COUNTY  
 CONCORD, MASSACHUSETTS  
 MAP: 9D | BLOCK: 2184 | LOT: 2

**BOHLER**  
 50 WASHINGTON ST., SUITE 2000  
 WESTBOROUGH, MA 01581  
 Phone: (508) 480-9900  
[www.BohlerEngineering.com](http://www.BohlerEngineering.com)

**J.A. KUCICH**  
 PROFESSIONAL ENGINEER  
 MASSACHUSETTS LICENSE No. 41530  
 NEW HAMPSHIRE LICENSE No. 15476  
 CONNECTICUT LICENSE No. 29177  
 RHODE ISLAND LICENSE No. 9616  
 MAINE LICENSE No. 12553

SHEET TITLE:  
**EXISTING CONDITIONS WATERSHED PLAN**  
 SHEET NUMBER:  
**C-402**  
 ORG. DATE - 11/06/2025

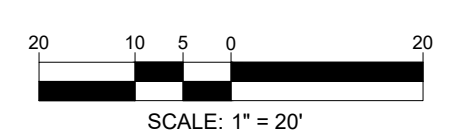
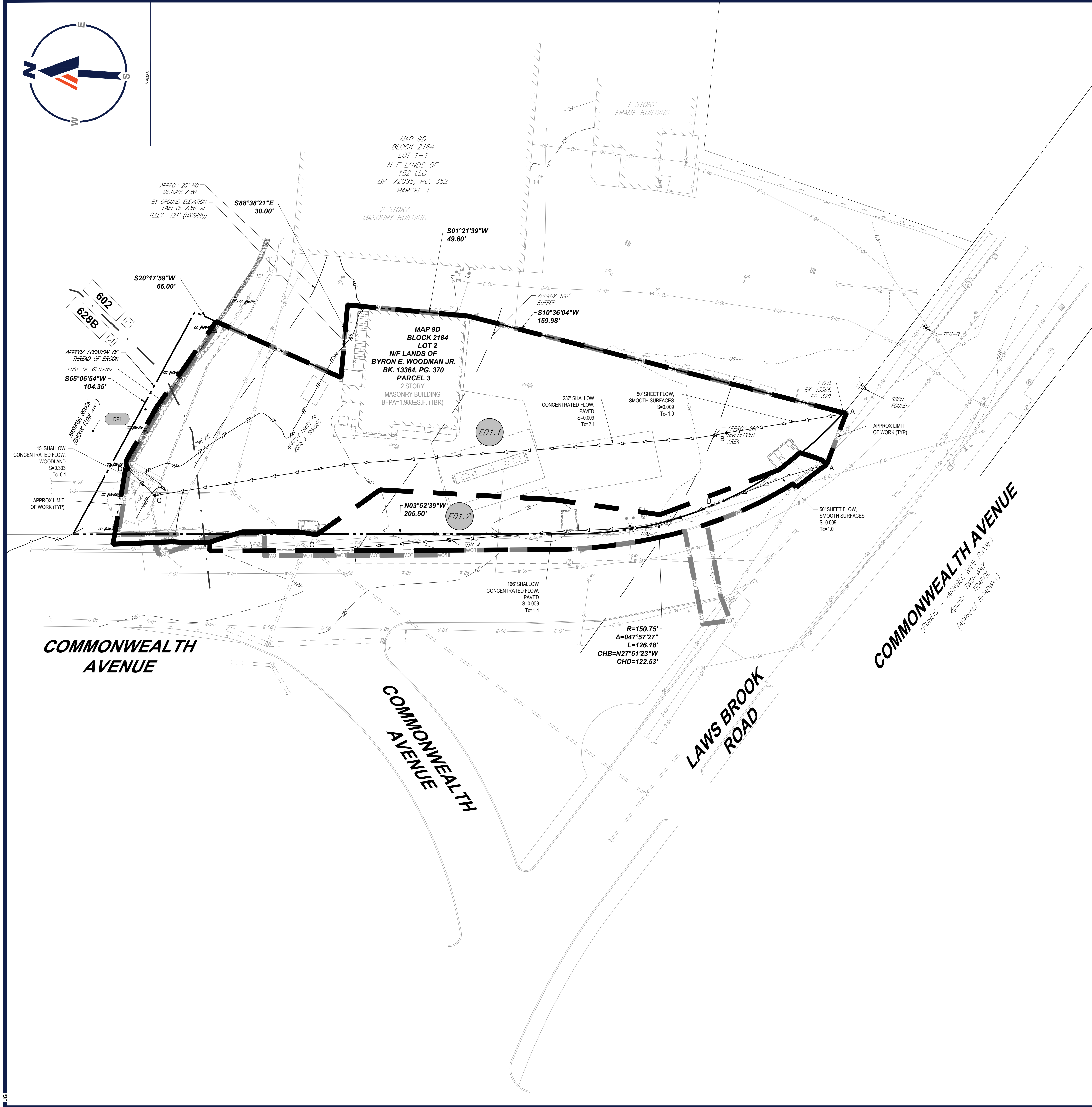

D:\02\_2025\18\BOHLER\NET\SHARES\MA-PROJECTS\2025\MAA250062.00\CAD\DRAWINGS\PLAN SETS\DRAINAGE AREA MAP\SP-DMAP-HYDR-MAA250062.00-0B-1-LAYOUT-C-402.PRED

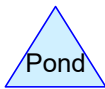
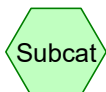
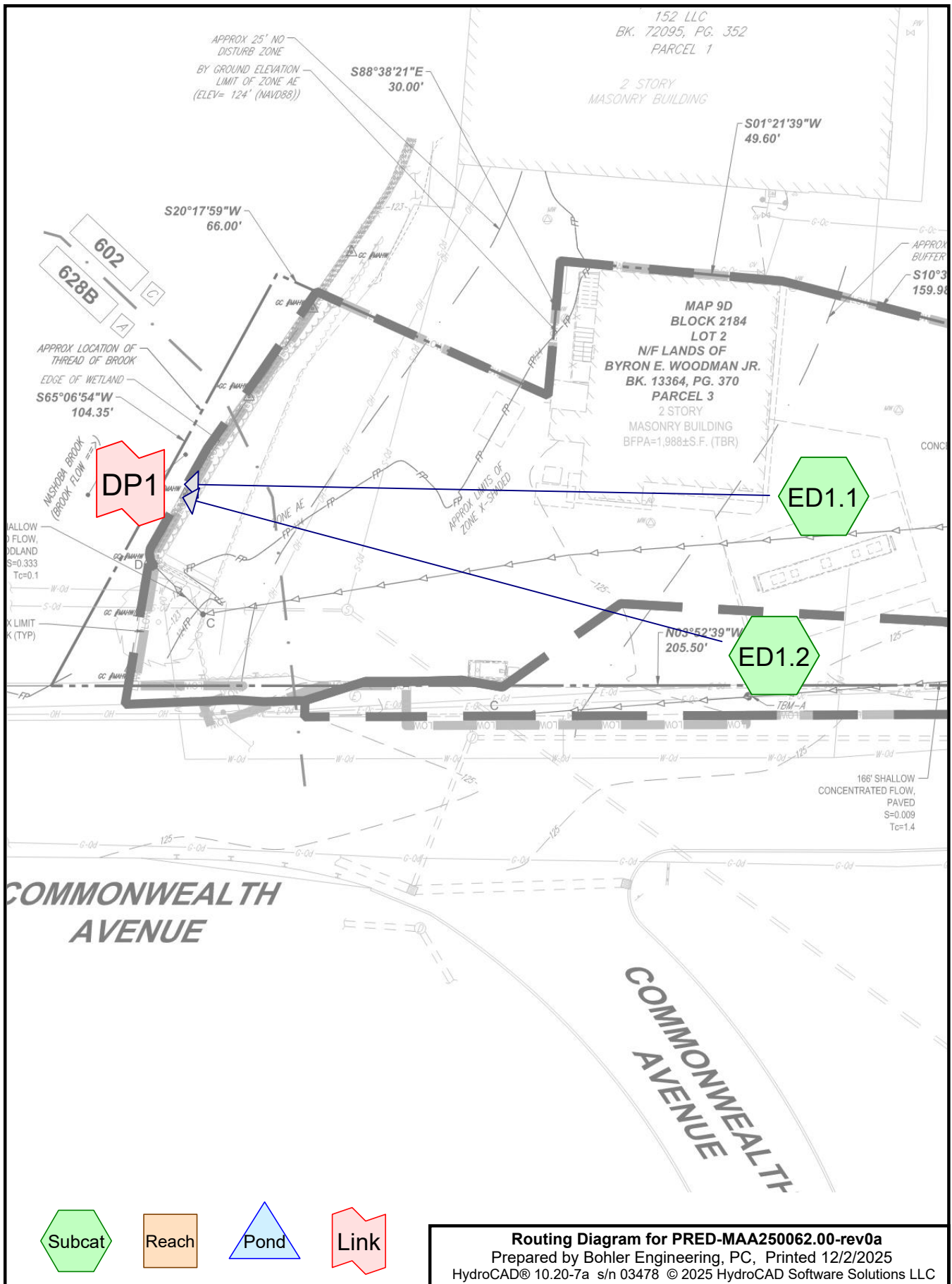

**Routing Diagram for PRED-MAA250062.00-rev0a**  
 Prepared by Bohler Engineering, PC, Printed 12/2/2025  
 HydroCAD® 10.20-7a s/n 03478 © 2025 HydroCAD Software Solutions LLC

**Rainfall Events Listing**

Event#	Event Name	Storm Type	Curve	Mode	Duration (hours)	B/B	Depth (inches)	AMC
1	2-Year	Type III 24-hr		Default	24.00	1	3.23	2
2	10-Year	Type III 24-hr		Default	24.00	1	5.02	2
3	25-Year	Type III 24-hr		Default	24.00	1	6.14	2
4	100-Year	Type III 24-hr		Default	24.00	1	7.87	2

**Area Listing (all nodes)**

Area (acres)	CN	Description (subcatchment-numbers)
0.004	74	>75% Grass cover, Good, HSG C (ED1.1, ED1.2)
0.021	98	Paved parking, HSG A (ED1.1)
0.410	98	Paved parking, HSG C (ED1.1, ED1.2)
0.050	98	Roofs, HSG C (ED1.1)
0.016	30	Woods, Good, HSG A (ED1.1)
0.006	70	Woods, Good, HSG C (ED1.1)
<b>0.507</b>	<b>95</b>	<b>TOTAL AREA</b>

**Soil Listing (all nodes)**

Area (acres)	Soil Group	Subcatchment Numbers
0.037	HSG A	ED1.1
0.000	HSG B	
0.470	HSG C	ED1.1, ED1.2
0.000	HSG D	
0.000	Other	
<b>0.507</b>		<b>TOTAL AREA</b>

**Ground Covers (all nodes)**

HSG-A (acres)	HSG-B (acres)	HSG-C (acres)	HSG-D (acres)	Other (acres)	Total (acres)	Ground Cover	Subcatchment Numbers
0.000	0.000	0.004	0.000	0.000	0.004	>75% Grass cover, Good	ED1.1, ED1.2
0.021	0.000	0.410	0.000	0.000	0.431	Paved parking	ED1.1, ED1.2
0.000	0.000	0.050	0.000	0.000	0.050	Roofs	ED1.1
0.016	0.000	0.006	0.000	0.000	0.022	Woods, Good	ED1.1
<b>0.037</b>	<b>0.000</b>	<b>0.470</b>	<b>0.000</b>	<b>0.000</b>	<b>0.507</b>	<b>TOTAL AREA</b>	

Time span=0.00-72.00 hrs, dt=0.01 hrs, 7201 points  
Runoff by SCS TR-20 method, UH=SCS, Weighted-Q  
Reach routing by Dyn-Stor-Ind method - Pond routing by Dyn-Stor-Ind method

**SubcatchmentED1.1:** Runoff Area=18,341 sf 94.19% Impervious Runoff Depth=2.84"  
Flow Length=302' Tc=6.0 min CN=WQ Runoff=1.25 cfs 0.100 af

**SubcatchmentED1.2:** Runoff Area=3,724 sf 98.90% Impervious Runoff Depth=2.98"  
Flow Length=216' Slope=0.0090 '/' Tc=6.0 min CN=WQ Runoff=0.27 cfs 0.021 af

**Link DP1:** Inflow=1.52 cfs 0.121 af  
Primary=1.52 cfs 0.121 af

**Total Runoff Area = 0.507 ac Runoff Volume = 0.121 af Average Runoff Depth = 2.86"**  
**5.01% Pervious = 0.025 ac 94.99% Impervious = 0.481 ac**

**Summary for Subcatchment ED1.1:**

Runoff = 1.25 cfs @ 12.08 hrs, Volume= 0.100 af, Depth= 2.84"  
 Routed to Link DP1 :

Runoff by SCS TR-20 method, UH=SCS, Weighted-Q, Time Span= 0.00-72.00 hrs, dt= 0.01 hrs  
 Type III 24-hr 2-Year Rainfall=3.23"

Area (sf)	CN	Description
2,173	98	Roofs, HSG C
126	74	>75% Grass cover, Good, HSG C
246	70	Woods, Good, HSG C
14,198	98	Paved parking, HSG C
693	30	Woods, Good, HSG A
905	98	Paved parking, HSG A
18,341		Weighted Average
1,065		5.81% Pervious Area
17,276		94.19% Impervious Area

Tc (min)	Length (feet)	Slope (ft/ft)	Velocity (ft/sec)	Capacity (cfs)	Description
1.0	50	0.0090	0.87		<b>Sheet Flow, A-B</b> Smooth surfaces n= 0.011 P2= 3.23"
2.1	237	0.0090	1.93		<b>Shallow Concentrated Flow, B-C</b> Paved Kv= 20.3 fps
0.1	15	0.3330	2.89		<b>Shallow Concentrated Flow, C-D</b> Woodland Kv= 5.0 fps
3.2	302	Total, Increased to minimum Tc = 6.0 min			

**Summary for Subcatchment ED1.2:**

Runoff = 0.27 cfs @ 12.08 hrs, Volume= 0.021 af, Depth= 2.98"

Routed to Link DP1 :

Runoff by SCS TR-20 method, UH=SCS, Weighted-Q, Time Span= 0.00-72.00 hrs, dt= 0.01 hrs  
 Type III 24-hr 2-Year Rainfall=3.23"

Area (sf)	CN	Description
41	74	>75% Grass cover, Good, HSG C
3,683	98	Paved parking, HSG C
3,724		Weighted Average
41		1.10% Pervious Area
3,683		98.90% Impervious Area

Tc (min)	Length (feet)	Slope (ft/ft)	Velocity (ft/sec)	Capacity (cfs)	Description
1.0	50	0.0090	0.87		<b>Sheet Flow, A-B</b> Smooth surfaces n= 0.011 P2= 3.23"
1.4	166	0.0090	1.93		<b>Shallow Concentrated Flow, B-C</b> Paved Kv= 20.3 fps
2.4	216	Total, Increased to minimum Tc = 6.0 min			

**Summary for Link DP1:**

Inflow Area = 0.507 ac, 94.99% Impervious, Inflow Depth = 2.86" for 2-Year event  
Inflow = 1.52 cfs @ 12.08 hrs, Volume= 0.121 af  
Primary = 1.52 cfs @ 12.08 hrs, Volume= 0.121 af, Atten= 0%, Lag= 0.0 min

Primary outflow = Inflow, Time Span= 0.00-72.00 hrs, dt= 0.01 hrs

Time span=0.00-72.00 hrs, dt=0.01 hrs, 7201 points  
Runoff by SCS TR-20 method, UH=SCS, Weighted-Q  
Reach routing by Dyn-Stor-Ind method - Pond routing by Dyn-Stor-Ind method

**SubcatchmentED1.1:** Runoff Area=18,341 sf 94.19% Impervious Runoff Depth=4.55"  
Flow Length=302' Tc=6.0 min CN=WQ Runoff=1.97 cfs 0.160 af

**SubcatchmentED1.2:** Runoff Area=3,724 sf 98.90% Impervious Runoff Depth=4.76"  
Flow Length=216' Slope=0.0090 '/' Tc=6.0 min CN=WQ Runoff=0.42 cfs 0.034 af

**Link DP1:** Inflow=2.39 cfs 0.194 af  
Primary=2.39 cfs 0.194 af

**Total Runoff Area = 0.507 ac Runoff Volume = 0.194 af Average Runoff Depth = 4.58"**  
**5.01% Pervious = 0.025 ac 94.99% Impervious = 0.481 ac**

**Summary for Subcatchment ED1.1:**

Runoff = 1.97 cfs @ 12.08 hrs, Volume= 0.160 af, Depth= 4.55"  
 Routed to Link DP1 :

Runoff by SCS TR-20 method, UH=SCS, Weighted-Q, Time Span= 0.00-72.00 hrs, dt= 0.01 hrs  
 Type III 24-hr 10-Year Rainfall=5.02"

Area (sf)	CN	Description
2,173	98	Roofs, HSG C
126	74	>75% Grass cover, Good, HSG C
246	70	Woods, Good, HSG C
14,198	98	Paved parking, HSG C
693	30	Woods, Good, HSG A
905	98	Paved parking, HSG A
18,341		Weighted Average
1,065		5.81% Pervious Area
17,276		94.19% Impervious Area

Tc (min)	Length (feet)	Slope (ft/ft)	Velocity (ft/sec)	Capacity (cfs)	Description
1.0	50	0.0090	0.87		<b>Sheet Flow, A-B</b> Smooth surfaces n= 0.011 P2= 3.23"
2.1	237	0.0090	1.93		<b>Shallow Concentrated Flow, B-C</b> Paved Kv= 20.3 fps
0.1	15	0.3330	2.89		<b>Shallow Concentrated Flow, C-D</b> Woodland Kv= 5.0 fps
3.2	302	Total, Increased to minimum Tc = 6.0 min			

**Summary for Subcatchment ED1.2:**

Runoff = 0.42 cfs @ 12.08 hrs, Volume= 0.034 af, Depth= 4.76"  
 Routed to Link DP1 :

Runoff by SCS TR-20 method, UH=SCS, Weighted-Q, Time Span= 0.00-72.00 hrs, dt= 0.01 hrs  
 Type III 24-hr 10-Year Rainfall=5.02"

Area (sf)	CN	Description
41	74	>75% Grass cover, Good, HSG C
3,683	98	Paved parking, HSG C
3,724		Weighted Average
41		1.10% Pervious Area
3,683		98.90% Impervious Area

Tc (min)	Length (feet)	Slope (ft/ft)	Velocity (ft/sec)	Capacity (cfs)	Description
1.0	50	0.0090	0.87		<b>Sheet Flow, A-B</b> Smooth surfaces n= 0.011 P2= 3.23"
1.4	166	0.0090	1.93		<b>Shallow Concentrated Flow, B-C</b> Paved Kv= 20.3 fps
2.4	216	Total, Increased to minimum Tc = 6.0 min			

**Summary for Link DP1:**

Inflow Area = 0.507 ac, 94.99% Impervious, Inflow Depth = 4.58" for 10-Year event  
Inflow = 2.39 cfs @ 12.08 hrs, Volume= 0.194 af  
Primary = 2.39 cfs @ 12.08 hrs, Volume= 0.194 af, Atten= 0%, Lag= 0.0 min

Primary outflow = Inflow, Time Span= 0.00-72.00 hrs, dt= 0.01 hrs

Time span=0.00-72.00 hrs, dt=0.01 hrs, 7201 points  
Runoff by SCS TR-20 method, UH=SCS, Weighted-Q  
Reach routing by Dyn-Stor-Ind method - Pond routing by Dyn-Stor-Ind method

**SubcatchmentED1.1:** Runoff Area=18,341 sf 94.19% Impervious Runoff Depth=5.62"  
Flow Length=302' Tc=6.0 min CN=WQ Runoff=2.42 cfs 0.197 af

**SubcatchmentED1.2:** Runoff Area=3,724 sf 98.90% Impervious Runoff Depth=5.87"  
Flow Length=216' Slope=0.0090 '/' Tc=6.0 min CN=WQ Runoff=0.51 cfs 0.042 af

**Link DP1:** Inflow=2.93 cfs 0.239 af  
Primary=2.93 cfs 0.239 af

**Total Runoff Area = 0.507 ac Runoff Volume = 0.239 af Average Runoff Depth = 5.67"**  
**5.01% Pervious = 0.025 ac 94.99% Impervious = 0.481 ac**

**Summary for Subcatchment ED1.1:**

Runoff = 2.42 cfs @ 12.08 hrs, Volume= 0.197 af, Depth= 5.62"  
 Routed to Link DP1 :

Runoff by SCS TR-20 method, UH=SCS, Weighted-Q, Time Span= 0.00-72.00 hrs, dt= 0.01 hrs  
 Type III 24-hr 25-Year Rainfall=6.14"

Area (sf)	CN	Description
2,173	98	Roofs, HSG C
126	74	>75% Grass cover, Good, HSG C
246	70	Woods, Good, HSG C
14,198	98	Paved parking, HSG C
693	30	Woods, Good, HSG A
905	98	Paved parking, HSG A
18,341		Weighted Average
1,065		5.81% Pervious Area
17,276		94.19% Impervious Area

Tc (min)	Length (feet)	Slope (ft/ft)	Velocity (ft/sec)	Capacity (cfs)	Description
1.0	50	0.0090	0.87		<b>Sheet Flow, A-B</b> Smooth surfaces n= 0.011 P2= 3.23"
2.1	237	0.0090	1.93		<b>Shallow Concentrated Flow, B-C</b> Paved Kv= 20.3 fps
0.1	15	0.3330	2.89		<b>Shallow Concentrated Flow, C-D</b> Woodland Kv= 5.0 fps
3.2	302	Total, Increased to minimum Tc = 6.0 min			

**Summary for Subcatchment ED1.2:**

Runoff = 0.51 cfs @ 12.08 hrs, Volume= 0.042 af, Depth= 5.87"  
 Routed to Link DP1 :

Runoff by SCS TR-20 method, UH=SCS, Weighted-Q, Time Span= 0.00-72.00 hrs, dt= 0.01 hrs  
 Type III 24-hr 25-Year Rainfall=6.14"

Area (sf)	CN	Description
41	74	>75% Grass cover, Good, HSG C
3,683	98	Paved parking, HSG C
3,724		Weighted Average
41		1.10% Pervious Area
3,683		98.90% Impervious Area

Tc (min)	Length (feet)	Slope (ft/ft)	Velocity (ft/sec)	Capacity (cfs)	Description
1.0	50	0.0090	0.87		<b>Sheet Flow, A-B</b> Smooth surfaces n= 0.011 P2= 3.23"
1.4	166	0.0090	1.93		<b>Shallow Concentrated Flow, B-C</b> Paved Kv= 20.3 fps
2.4	216	Total, Increased to minimum Tc = 6.0 min			

**Summary for Link DP1:**

Inflow Area = 0.507 ac, 94.99% Impervious, Inflow Depth = 5.67" for 25-Year event

Inflow = 2.93 cfs @ 12.08 hrs, Volume= 0.239 af

Primary = 2.93 cfs @ 12.08 hrs, Volume= 0.239 af, Atten= 0%, Lag= 0.0 min

Primary outflow = Inflow, Time Span= 0.00-72.00 hrs, dt= 0.01 hrs

Time span=0.00-72.00 hrs, dt=0.01 hrs, 7201 points  
Runoff by SCS TR-20 method, UH=SCS, Weighted-Q  
Reach routing by Dyn-Stor-Ind method - Pond routing by Dyn-Stor-Ind method

**SubcatchmentED1.1:** Runoff Area=18,341 sf 94.19% Impervious Runoff Depth=7.29"  
Flow Length=302' Tc=6.0 min CN=WQ Runoff=3.11 cfs 0.256 af

**SubcatchmentED1.2:** Runoff Area=3,724 sf 98.90% Impervious Runoff Depth=7.60"  
Flow Length=216' Slope=0.0090 '/' Tc=6.0 min CN=WQ Runoff=0.66 cfs 0.054 af

**Link DP1:** Inflow=3.77 cfs 0.310 af  
Primary=3.77 cfs 0.310 af

**Total Runoff Area = 0.507 ac Runoff Volume = 0.310 af Average Runoff Depth = 7.34"**  
**5.01% Pervious = 0.025 ac 94.99% Impervious = 0.481 ac**

**Summary for Subcatchment ED1.1:**

Runoff = 3.11 cfs @ 12.08 hrs, Volume= 0.256 af, Depth= 7.29"  
 Routed to Link DP1 :

Runoff by SCS TR-20 method, UH=SCS, Weighted-Q, Time Span= 0.00-72.00 hrs, dt= 0.01 hrs  
 Type III 24-hr 100-Year Rainfall=7.87"

Area (sf)	CN	Description
2,173	98	Roofs, HSG C
126	74	>75% Grass cover, Good, HSG C
246	70	Woods, Good, HSG C
14,198	98	Paved parking, HSG C
693	30	Woods, Good, HSG A
905	98	Paved parking, HSG A
18,341		Weighted Average
1,065		5.81% Pervious Area
17,276		94.19% Impervious Area

Tc (min)	Length (feet)	Slope (ft/ft)	Velocity (ft/sec)	Capacity (cfs)	Description
1.0	50	0.0090	0.87		<b>Sheet Flow, A-B</b> Smooth surfaces n= 0.011 P2= 3.23"
2.1	237	0.0090	1.93		<b>Shallow Concentrated Flow, B-C</b> Paved Kv= 20.3 fps
0.1	15	0.3330	2.89		<b>Shallow Concentrated Flow, C-D</b> Woodland Kv= 5.0 fps
3.2	302	Total, Increased to minimum Tc = 6.0 min			

**Summary for Subcatchment ED1.2:**

Runoff = 0.66 cfs @ 12.08 hrs, Volume= 0.054 af, Depth= 7.60"  
 Routed to Link DP1 :

Runoff by SCS TR-20 method, UH=SCS, Weighted-Q, Time Span= 0.00-72.00 hrs, dt= 0.01 hrs  
 Type III 24-hr 100-Year Rainfall=7.87"

Area (sf)	CN	Description
41	74	>75% Grass cover, Good, HSG C
3,683	98	Paved parking, HSG C
3,724		Weighted Average
41		1.10% Pervious Area
3,683		98.90% Impervious Area

Tc (min)	Length (feet)	Slope (ft/ft)	Velocity (ft/sec)	Capacity (cfs)	Description
1.0	50	0.0090	0.87		<b>Sheet Flow, A-B</b> Smooth surfaces n= 0.011 P2= 3.23"
1.4	166	0.0090	1.93		<b>Shallow Concentrated Flow, B-C</b> Paved Kv= 20.3 fps
2.4	216	Total, Increased to minimum Tc = 6.0 min			

**Summary for Link DP1:**

Inflow Area = 0.507 ac, 94.99% Impervious, Inflow Depth = 7.34" for 100-Year event  
Inflow = 3.77 cfs @ 12.08 hrs, Volume= 0.310 af  
Primary = 3.77 cfs @ 12.08 hrs, Volume= 0.310 af, Atten= 0%, Lag= 0.0 min

Primary outflow = Inflow, Time Span= 0.00-72.00 hrs, dt= 0.01 hrs

## **APPENDIX E: PROPOSED CONDITIONS HYDROLOGIC ANALYSIS**

- PROPOSED CONDITIONS DRAINAGE MAP
- PROPOSED CONDITIONS HYDROCAD CALCULATIONS

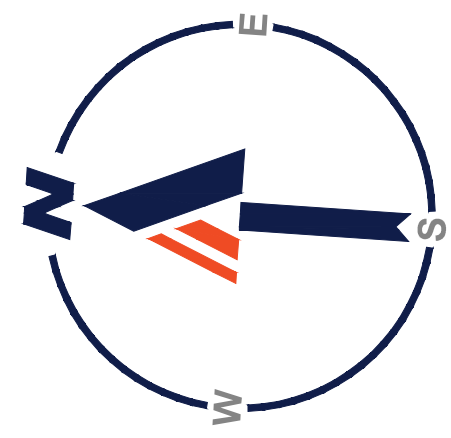

LEGEND	
PROPOSED WATERSHED	
DESIGN POINT	
SUBCATCHMENT ID	
SUBCATCHMENT BOUNDARY	
TIME OF CONCENTRATION PATH	
SOIL BOUNDARY WITH NRCS MAP UNIT AND HYDROLOGIC SOIL GROUP RATINGS	

**BOHLER**  
 SITE CIVIL AND CONSULTING ENGINEERING  
 PROGRAM MANAGEMENT  
 LANDSCAPE ARCHITECTURE  
 SUSTAINABLE DESIGN  
 PERMITTING SERVICES  
 TRANSPORTATION SERVICES

REVISIONS				
REV	DATE	COMMENT	DRAWN BY	CHECKED BY

**811**  
 Know what's below.  
 Call before you dig.  
 ALWAYS CALL 811  
 It's fast. It's free. It's the law.

**ISSUED FOR ENTITLEMENTS**

PROJECT No.: MAA250062.00-0B  
 DRAWN BY: JDG  
 CHECKED BY: CSE  
 DATE: 11/06/2025  
 CAD I.D.: P-DMAP-HYDR

**PROPOSED SITE PLAN DOCUMENTS**

FOR  
**ROUTE 85 REALTY CORP.**  
 PROPOSED  
 RETAIL STORE AND  
 AUTO SERVICE STATION  
 166 COMMONWEALTH AVENUE  
 MIDDLESEX COUNTY  
 CONCORD, MASSACHUSETTS  
 MAP: 9D | BLOCK: 2184 | LOT: 2

**BOHLER**  
 50 WASHINGTON ST., SUITE 2000  
 WESTBOROUGH, MA 01581  
 Phone: (508) 480-9900  
[www.BohlerEngineering.com](http://www.BohlerEngineering.com)

**J.A. KUCICH**  
 PROFESSIONAL ENGINEER  
 MASSACHUSETTS LICENSE No. 41530  
 NEW HAMPSHIRE LICENSE No. 15476  
 CONNECTICUT LICENSE No. 29177  
 RHODE ISLAND LICENSE No. 9616  
 MAINE LICENSE No. 12553

**PROPOSED CONDITIONS WATERSHED PLAN**

SHEET NUMBER:  
**C-403**

ORG. DATE - 11/06/2025

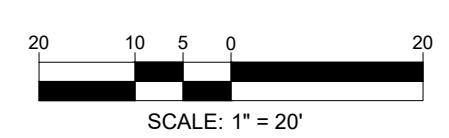
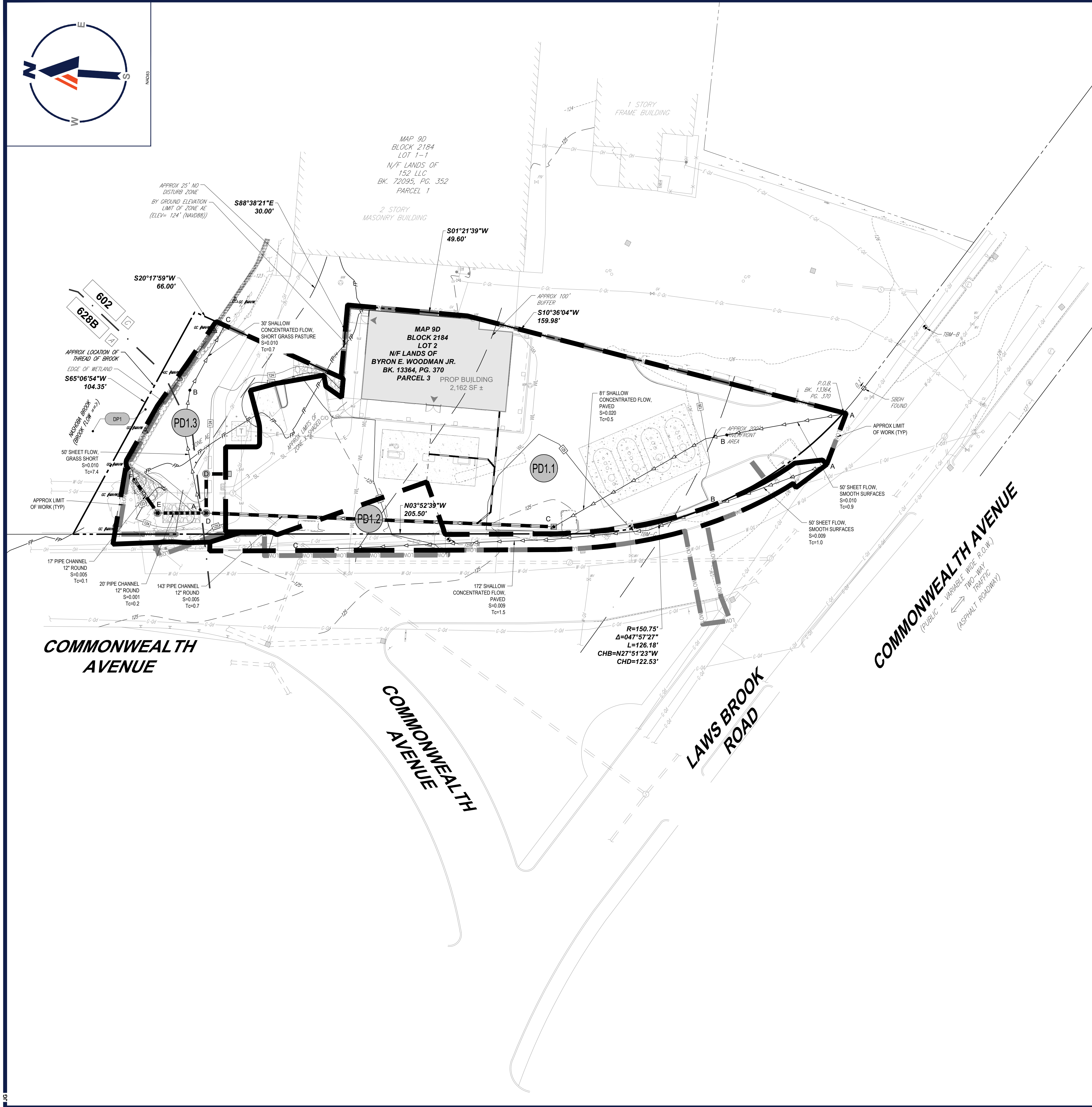

D:\02\_2025\18\BOHLER\NET\SHARES\MA-PROJECTS\2025\MAA250062.00\DRAWINGS\PLAN SETS\DRAINAGE AREA MAP\SP-DMAP-HYDR-MAA250062.00-0B-1-LAYOUT-C-403.PSTB

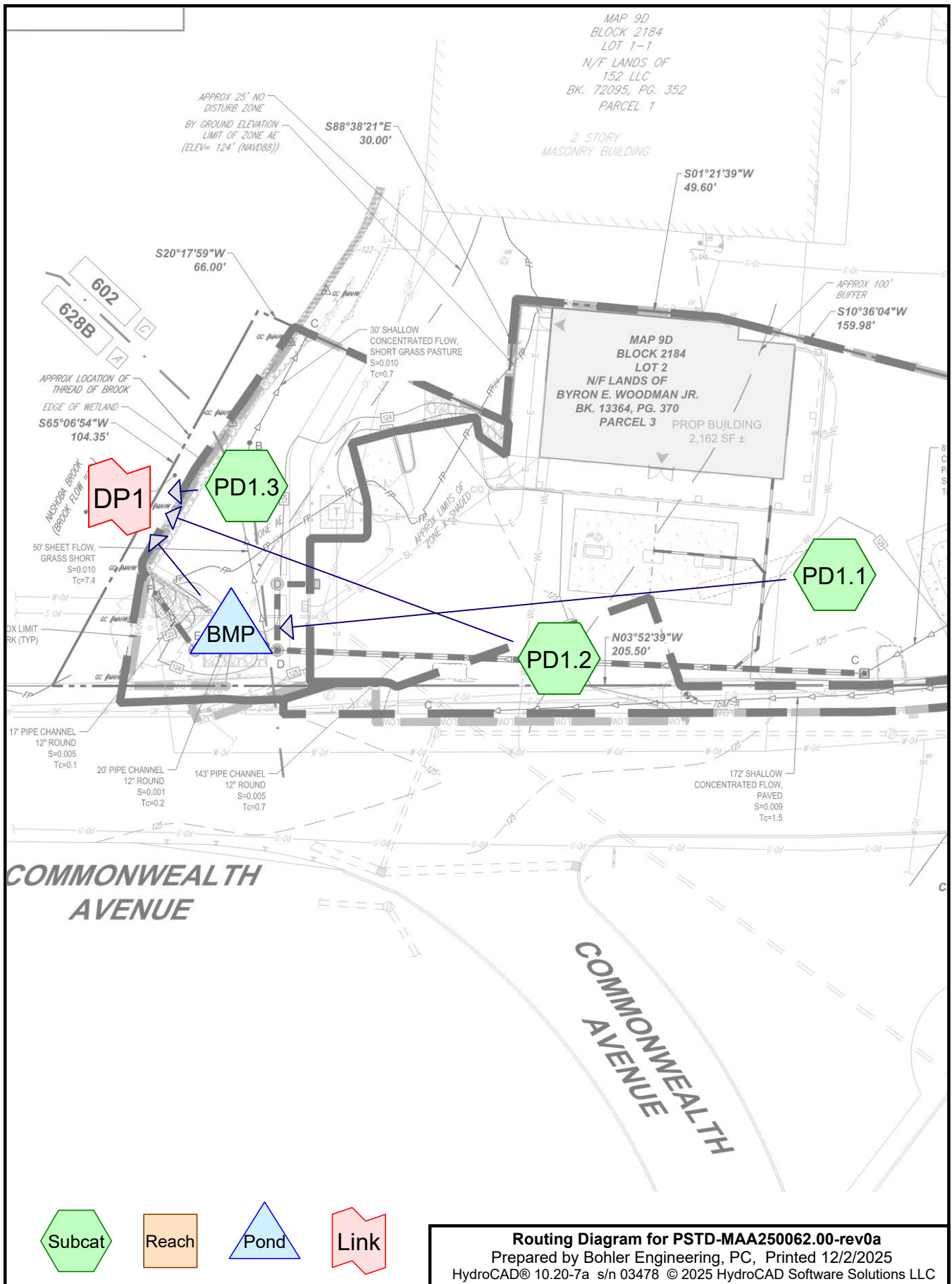

**Rainfall Events Listing**

Event#	Event Name	Storm Type	Curve	Mode	Duration (hours)	B/B	Depth (inches)	AMC
1	2-Year	Type III 24-hr		Default	24.00	1	3.23	2
2	10-Year	Type III 24-hr		Default	24.00	1	5.02	2
3	25-Year	Type III 24-hr		Default	24.00	1	6.14	2
4	100-Year	Type III 24-hr		Default	24.00	1	7.87	2

**Area Listing (all nodes)**

Area (acres)	CN	Description (subcatchment-numbers)
0.022	39	>75% Grass cover, Good, HSG A (PD1.3)
0.055	74	>75% Grass cover, Good, HSG C (PD1.1, PD1.2, PD1.3)
0.007	98	Paved parking, HSG A (PD1.3)
0.330	98	Paved parking, HSG C (PD1.1, PD1.2, PD1.3)
0.084	98	Roofs, HSG C (PD1.1)
0.008	30	Woods, Good, HSG A (PD1.3)
0.001	70	Woods, Good, HSG C (PD1.3)
<b>0.507</b>	<b>92</b>	<b>TOTAL AREA</b>

**Soil Listing (all nodes)**

Area (acres)	Soil Group	Subcatchment Numbers
0.037	HSG A	PD1.3
0.000	HSG B	
0.470	HSG C	PD1.1, PD1.2, PD1.3
0.000	HSG D	
0.000	Other	
<b>0.507</b>		<b>TOTAL AREA</b>

**Ground Covers (all nodes)**

HSG-A (acres)	HSG-B (acres)	HSG-C (acres)	HSG-D (acres)	Other (acres)	Total (acres)	Ground Cover	Subcatchment Numbers
0.022	0.000	0.055	0.000	0.000	0.077	>75% Grass cover, Good	PD1.1, PD1.2, PD1.3
0.007	0.000	0.330	0.000	0.000	0.337	Paved parking	PD1.1, PD1.2, PD1.3
0.000	0.000	0.084	0.000	0.000	0.084	Roofs	PD1.1
0.008	0.000	0.001	0.000	0.000	0.009	Woods, Good	PD1.3
<b>0.037</b>	<b>0.000</b>	<b>0.470</b>	<b>0.000</b>	<b>0.000</b>	<b>0.507</b>	<b>TOTAL AREA</b>	

**PSTD-MAA250062.00-rev0a**

Prepared by Bohler Engineering, PC

HydroCAD® 10.20-7a s/n 03478 © 2025 HydroCAD Software Solutions LLC

Printed 12/2/2025

Page 6

**Pipe Listing (all nodes)**

Line#	Node Number	In-Invert (feet)	Out-Invert (feet)	Length (feet)	Slope (ft/ft)	n	Width (inches)	Diam/Height (inches)	Inside-Fill (inches)	Node Name
1	PD1.1	0.00	0.00	143.0	0.0050	0.013	0.0	12.0	0.0	
2	PD1.1	0.00	0.00	20.0	0.0010	0.013	0.0	12.0	0.0	
3	PD1.1	0.00	0.00	17.0	0.0050	0.013	0.0	12.0	0.0	
4	BMP	120.40	120.30	17.0	0.0059	0.013	0.0	12.0	0.0	

Time span=0.00-72.00 hrs, dt=0.01 hrs, 7201 points  
Runoff by SCS TR-20 method, UH=SCS, Weighted-Q  
Reach routing by Dyn-Stor-Ind method - Pond routing by Dyn-Stor-Ind method

**SubcatchmentPD1.1:** Runoff Area=15,874 sf 94.63% Impervious Runoff Depth=2.89"  
Flow Length=311' Tc=6.0 min CN=WQ Runoff=1.10 cfs 0.088 af

**SubcatchmentPD1.2:** Runoff Area=2,438 sf 99.75% Impervious Runoff Depth=2.99"  
Flow Length=222' Slope=0.0090 '/' Tc=6.0 min CN=WQ Runoff=0.18 cfs 0.014 af

**SubcatchmentPD1.3:** Runoff Area=3,754 sf 23.26% Impervious Runoff Depth=1.14"  
Flow Length=80' Slope=0.0100 '/' Tc=8.1 min CN=WQ Runoff=0.10 cfs 0.008 af

**Pond BMP:** Peak Elev=121.79' Storage=96 cf Inflow=1.10 cfs 0.088 af  
Discarded=0.01 cfs 0.014 af Primary=1.10 cfs 0.074 af Outflow=1.10 cfs 0.088 af

**Link DP1:** Inflow=1.37 cfs 0.096 af  
Primary=1.37 cfs 0.096 af

**Total Runoff Area = 0.507 ac Runoff Volume = 0.110 af Average Runoff Depth = 2.61"**  
**16.95% Pervious = 0.086 ac 83.05% Impervious = 0.421 ac**

**Summary for Subcatchment PD1.1:**

Runoff = 1.10 cfs @ 12.08 hrs, Volume= 0.088 af, Depth= 2.89"

Routed to Pond BMP :

Runoff by SCS TR-20 method, UH=SCS, Weighted-Q, Time Span= 0.00-72.00 hrs, dt= 0.01 hrs  
 Type III 24-hr 2-Year Rainfall=3.23"

Area (sf)	CN	Description
3,661	98	Roofs, HSG C
853	74	>75% Grass cover, Good, HSG C
11,360	98	Paved parking, HSG C
15,874		Weighted Average
853		5.37% Pervious Area
15,021		94.63% Impervious Area

Tc (min)	Length (feet)	Slope (ft/ft)	Velocity (ft/sec)	Capacity (cfs)	Description
0.9	50	0.0100	0.91		<b>Sheet Flow, A-B</b> Smooth surfaces n= 0.011 P2= 3.23"
0.5	81	0.0200	2.87		<b>Shallow Concentrated Flow, B-C</b> Paved Kv= 20.3 fps
0.7	143	0.0050	3.21	2.52	<b>Pipe Channel, C-D</b> 12.0" Round Area= 0.8 sf Perim= 3.1' r= 0.25' n= 0.013 Corrugated PE, smooth interior
0.2	20	0.0010	1.43	1.13	<b>Pipe Channel, D-E</b> 12.0" Round Area= 0.8 sf Perim= 3.1' r= 0.25' n= 0.013 Corrugated PE, smooth interior
0.1	17	0.0050	3.21	2.52	<b>Pipe Channel, E-F</b> 12.0" Round Area= 0.8 sf Perim= 3.1' r= 0.25' n= 0.013 Corrugated PE, smooth interior
2.4	311	Total, Increased to minimum Tc = 6.0 min			

**Summary for Subcatchment PD1.2:**

Runoff = 0.18 cfs @ 12.08 hrs, Volume= 0.014 af, Depth= 2.99"  
 Routed to Link DP1 :

Runoff by SCS TR-20 method, UH=SCS, Weighted-Q, Time Span= 0.00-72.00 hrs, dt= 0.01 hrs  
 Type III 24-hr 2-Year Rainfall=3.23"

Area (sf)	CN	Description
6	74	>75% Grass cover, Good, HSG C
2,432	98	Paved parking, HSG C
2,438		Weighted Average
6		0.25% Pervious Area
2,432		99.75% Impervious Area

Tc (min)	Length (feet)	Slope (ft/ft)	Velocity (ft/sec)	Capacity (cfs)	Description
1.0	50	0.0090	0.87		<b>Sheet Flow, A-B</b> Smooth surfaces n= 0.011 P2= 3.23"
1.5	172	0.0090	1.93		<b>Shallow Concentrated Flow, B-C</b> Paved Kv= 20.3 fps
2.5	222	Total, Increased to minimum Tc = 6.0 min			

**Summary for Subcatchment PD1.3:**

Runoff = 0.10 cfs @ 12.12 hrs, Volume= 0.008 af, Depth= 1.14"  
 Routed to Link DP1 :

Runoff by SCS TR-20 method, UH=SCS, Weighted-Q, Time Span= 0.00-72.00 hrs, dt= 0.01 hrs  
 Type III 24-hr 2-Year Rainfall=3.23"

Area (sf)	CN	Description
573	98	Paved parking, HSG C
1,539	74	>75% Grass cover, Good, HSG C
43	70	Woods, Good, HSG C
300	98	Paved parking, HSG A
964	39	>75% Grass cover, Good, HSG A
335	30	Woods, Good, HSG A
3,754		Weighted Average
2,881		76.74% Pervious Area
873		23.26% Impervious Area

Tc (min)	Length (feet)	Slope (ft/ft)	Velocity (ft/sec)	Capacity (cfs)	Description
7.4	50	0.0100	0.11		<b>Sheet Flow, A-B</b>
					Grass: Short n= 0.150 P2= 3.23"
0.7	30	0.0100	0.70		<b>Shallow Concentrated Flow, B-C</b>
					Short Grass Pasture Kv= 7.0 fps
8.1	80	Total			

**Summary for Pond BMP:**

Inflow Area = 0.364 ac, 94.63% Impervious, Inflow Depth = 2.89" for 2-Year event  
 Inflow = 1.10 cfs @ 12.08 hrs, Volume= 0.088 af  
 Outflow = 1.10 cfs @ 12.09 hrs, Volume= 0.088 af, Atten= 0%, Lag= 0.1 min  
 Discarded = 0.01 cfs @ 3.98 hrs, Volume= 0.014 af  
 Primary = 1.10 cfs @ 12.09 hrs, Volume= 0.074 af

Routed to Link DP1 :

Routing by Dyn-Stor-Ind method, Time Span= 0.00-72.00 hrs, dt= 0.01 hrs  
 Peak Elev= 121.79' @ 12.09 hrs Surf.Area= 120 sf Storage= 96 cf

Plug-Flow detention time= 26.8 min calculated for 0.088 af (100% of inflow)  
 Center-of-Mass det. time= 26.8 min ( 785.1 - 758.3 )

Volume	Invert	Avail.Storage	Storage Description
#1	119.90'	94 cf	<b>Custom Stage Data (Prismatic)</b> Listed below (Recalc) 252 cf Overall - 17 cf Embedded = 235 cf x 40.0% Voids
#2	120.40'	12 cf	<b>12.0" Round Pipe Storage</b> Inside #1 L= 15.0' 17 cf Overall - 1.2" Wall Thickness = 12 cf
		106 cf	Total Available Storage

Elevation (feet)	Surf.Area (sq-ft)	Inc.Store (cubic-feet)	Cum.Store (cubic-feet)
119.90	120	0	0
120.00	120	12	12
121.00	120	120	132
122.00	120	120	252

Device	Routing	Invert	Outlet Devices
#1	Primary	120.40'	<b>12.0" Round Culvert</b> L= 17.0' CPP, square edge headwall, Ke= 0.500 Inlet / Outlet Invert= 120.40' / 120.30' S= 0.0059 '/' Cc= 0.900 n= 0.013 Corrugated PE, smooth interior, Flow Area= 0.79 sf
#2	Device 1	121.60'	<b>4.0' long Sharp-Crested Rectangular Weir</b> 2 End Contraction(s)
#3	Discarded	119.90'	<b>2.410 in/hr Exfiltration over Surface area</b> Phase-In= 0.01'

**Discarded OutFlow** Max=0.01 cfs @ 3.98 hrs HW=119.92' (Free Discharge)  
 ↳ **3=Exfiltration** (Exfiltration Controls 0.01 cfs)

**Primary OutFlow** Max=1.10 cfs @ 12.09 hrs HW=121.79' TW=0.00' (Dynamic Tailwater)  
 ↳ **1=Culvert** (Passes 1.10 cfs of 3.10 cfs potential flow)  
 ↳ **2=Sharp-Crested Rectangular Weir**(Weir Controls 1.10 cfs @ 1.44 fps)

**Summary for Link DP1:**

Inflow Area = 0.507 ac, 83.05% Impervious, Inflow Depth = 2.28" for 2-Year event  
Inflow = 1.37 cfs @ 12.09 hrs, Volume= 0.096 af  
Primary = 1.37 cfs @ 12.09 hrs, Volume= 0.096 af, Atten= 0%, Lag= 0.0 min

Primary outflow = Inflow, Time Span= 0.00-72.00 hrs, dt= 0.01 hrs

Time span=0.00-72.00 hrs, dt=0.01 hrs, 7201 points  
Runoff by SCS TR-20 method, UH=SCS, Weighted-Q  
Reach routing by Dyn-Stor-Ind method - Pond routing by Dyn-Stor-Ind method

**SubcatchmentPD1.1:** Runoff Area=15,874 sf 94.63% Impervious Runoff Depth=4.65"  
Flow Length=311' Tc=6.0 min CN=WQ Runoff=1.75 cfs 0.141 af

**SubcatchmentPD1.2:** Runoff Area=2,438 sf 99.75% Impervious Runoff Depth=4.78"  
Flow Length=222' Slope=0.0090 '/' Tc=6.0 min CN=WQ Runoff=0.27 cfs 0.022 af

**SubcatchmentPD1.3:** Runoff Area=3,754 sf 23.26% Impervious Runoff Depth=2.16"  
Flow Length=80' Slope=0.0100 '/' Tc=8.1 min CN=WQ Runoff=0.18 cfs 0.016 af

**Pond BMP:** Peak Elev=121.86' Storage=99 cf Inflow=1.75 cfs 0.141 af  
Discarded=0.01 cfs 0.015 af Primary=1.74 cfs 0.127 af Outflow=1.75 cfs 0.141 af

**Link DP1:** Inflow=2.19 cfs 0.165 af  
Primary=2.19 cfs 0.165 af

**Total Runoff Area = 0.507 ac Runoff Volume = 0.179 af Average Runoff Depth = 4.24"**  
**16.95% Pervious = 0.086 ac 83.05% Impervious = 0.421 ac**

**Summary for Subcatchment PD1.1:**

[47] Hint: Peak is 155% of capacity of segment #4

Runoff = 1.75 cfs @ 12.08 hrs, Volume= 0.141 af, Depth= 4.65"  
 Routed to Pond BMP :

Runoff by SCS TR-20 method, UH=SCS, Weighted-Q, Time Span= 0.00-72.00 hrs, dt= 0.01 hrs  
 Type III 24-hr 10-Year Rainfall=5.02"

Area (sf)	CN	Description
3,661	98	Roofs, HSG C
853	74	>75% Grass cover, Good, HSG C
11,360	98	Paved parking, HSG C
15,874		Weighted Average
853		5.37% Pervious Area
15,021		94.63% Impervious Area

Tc (min)	Length (feet)	Slope (ft/ft)	Velocity (ft/sec)	Capacity (cfs)	Description
0.9	50	0.0100	0.91		<b>Sheet Flow, A-B</b> Smooth surfaces n= 0.011 P2= 3.23"
0.5	81	0.0200	2.87		<b>Shallow Concentrated Flow, B-C</b> Paved Kv= 20.3 fps
0.7	143	0.0050	3.21	2.52	<b>Pipe Channel, C-D</b> 12.0" Round Area= 0.8 sf Perim= 3.1' r= 0.25' n= 0.013 Corrugated PE, smooth interior
0.2	20	0.0010	1.43	1.13	<b>Pipe Channel, D-E</b> 12.0" Round Area= 0.8 sf Perim= 3.1' r= 0.25' n= 0.013 Corrugated PE, smooth interior
0.1	17	0.0050	3.21	2.52	<b>Pipe Channel, E-F</b> 12.0" Round Area= 0.8 sf Perim= 3.1' r= 0.25' n= 0.013 Corrugated PE, smooth interior
2.4	311	Total, Increased to minimum Tc = 6.0 min			

**Summary for Subcatchment PD1.2:**

Runoff = 0.27 cfs @ 12.08 hrs, Volume= 0.022 af, Depth= 4.78"  
 Routed to Link DP1 :

Runoff by SCS TR-20 method, UH=SCS, Weighted-Q, Time Span= 0.00-72.00 hrs, dt= 0.01 hrs  
 Type III 24-hr 10-Year Rainfall=5.02"

Area (sf)	CN	Description
6	74	>75% Grass cover, Good, HSG C
2,432	98	Paved parking, HSG C
2,438		Weighted Average
6		0.25% Pervious Area
2,432		99.75% Impervious Area

Tc (min)	Length (feet)	Slope (ft/ft)	Velocity (ft/sec)	Capacity (cfs)	Description
1.0	50	0.0090	0.87		<b>Sheet Flow, A-B</b> Smooth surfaces n= 0.011 P2= 3.23"
1.5	172	0.0090	1.93		<b>Shallow Concentrated Flow, B-C</b> Paved Kv= 20.3 fps
2.5	222	Total, Increased to minimum Tc = 6.0 min			

**Summary for Subcatchment PD1.3:**

Runoff = 0.18 cfs @ 12.11 hrs, Volume= 0.016 af, Depth= 2.16"  
 Routed to Link DP1 :

Runoff by SCS TR-20 method, UH=SCS, Weighted-Q, Time Span= 0.00-72.00 hrs, dt= 0.01 hrs  
 Type III 24-hr 10-Year Rainfall=5.02"

Area (sf)	CN	Description
573	98	Paved parking, HSG C
1,539	74	>75% Grass cover, Good, HSG C
43	70	Woods, Good, HSG C
300	98	Paved parking, HSG A
964	39	>75% Grass cover, Good, HSG A
335	30	Woods, Good, HSG A
3,754		Weighted Average
2,881		76.74% Pervious Area
873		23.26% Impervious Area

Tc (min)	Length (feet)	Slope (ft/ft)	Velocity (ft/sec)	Capacity (cfs)	Description
7.4	50	0.0100	0.11		<b>Sheet Flow, A-B</b>
					Grass: Short n= 0.150 P2= 3.23"
0.7	30	0.0100	0.70		<b>Shallow Concentrated Flow, B-C</b>
					Short Grass Pasture Kv= 7.0 fps
8.1	80	Total			

**Summary for Pond BMP:**

Inflow Area = 0.364 ac, 94.63% Impervious, Inflow Depth = 4.65" for 10-Year event  
 Inflow = 1.75 cfs @ 12.08 hrs, Volume= 0.141 af  
 Outflow = 1.75 cfs @ 12.08 hrs, Volume= 0.141 af, Atten= 0%, Lag= 0.1 min  
 Discarded = 0.01 cfs @ 2.28 hrs, Volume= 0.015 af  
 Primary = 1.74 cfs @ 12.08 hrs, Volume= 0.127 af

Routed to Link DP1 :

Routing by Dyn-Stor-Ind method, Time Span= 0.00-72.00 hrs, dt= 0.01 hrs  
 Peak Elev= 121.86' @ 12.08 hrs Surf.Area= 120 sf Storage= 99 cf

Plug-Flow detention time= 18.6 min calculated for 0.141 af (100% of inflow)  
 Center-of-Mass det. time= 18.6 min ( 769.0 - 750.4 )

Volume	Invert	Avail.Storage	Storage Description
#1	119.90'	94 cf	<b>Custom Stage Data (Prismatic)</b> Listed below (Recalc) 252 cf Overall - 17 cf Embedded = 235 cf x 40.0% Voids
#2	120.40'	12 cf	<b>12.0" Round Pipe Storage</b> Inside #1 L= 15.0' 17 cf Overall - 1.2" Wall Thickness = 12 cf
		106 cf	Total Available Storage

Elevation (feet)	Surf.Area (sq-ft)	Inc.Store (cubic-feet)	Cum.Store (cubic-feet)
119.90	120	0	0
120.00	120	12	12
121.00	120	120	132
122.00	120	120	252

Device	Routing	Invert	Outlet Devices
#1	Primary	120.40'	<b>12.0" Round Culvert</b> L= 17.0' CPP, square edge headwall, Ke= 0.500 Inlet / Outlet Invert= 120.40' / 120.30' S= 0.0059 '/' Cc= 0.900 n= 0.013 Corrugated PE, smooth interior, Flow Area= 0.79 sf
#2	Device 1	121.60'	<b>4.0' long Sharp-Crested Rectangular Weir</b> 2 End Contraction(s)
#3	Discarded	119.90'	<b>2.410 in/hr Exfiltration over Surface area</b> Phase-In= 0.01'

**Discarded OutFlow** Max=0.01 cfs @ 2.28 hrs HW=119.92' (Free Discharge)  
 ↳ **3=Exfiltration** (Exfiltration Controls 0.01 cfs)

**Primary OutFlow** Max=1.74 cfs @ 12.08 hrs HW=121.86' TW=0.00' (Dynamic Tailwater)  
 ↳ **1=Culvert** (Passes 1.74 cfs of 3.32 cfs potential flow)  
 ↳ **2=Sharp-Crested Rectangular Weir**(Weir Controls 1.74 cfs @ 1.68 fps)

**Summary for Link DP1:**

Inflow Area = 0.507 ac, 83.05% Impervious, Inflow Depth = 3.90" for 10-Year event  
Inflow = 2.19 cfs @ 12.09 hrs, Volume= 0.165 af  
Primary = 2.19 cfs @ 12.09 hrs, Volume= 0.165 af, Atten= 0%, Lag= 0.0 min

Primary outflow = Inflow, Time Span= 0.00-72.00 hrs, dt= 0.01 hrs

Time span=0.00-72.00 hrs, dt=0.01 hrs, 7201 points  
Runoff by SCS TR-20 method, UH=SCS, Weighted-Q  
Reach routing by Dyn-Stor-Ind method - Pond routing by Dyn-Stor-Ind method

**SubcatchmentPD1.1:** Runoff Area=15,874 sf 94.63% Impervious Runoff Depth=5.76"  
Flow Length=311' Tc=6.0 min CN=WQ Runoff=2.15 cfs 0.175 af

**SubcatchmentPD1.2:** Runoff Area=2,438 sf 99.75% Impervious Runoff Depth=5.90"  
Flow Length=222' Slope=0.0090 '/' Tc=6.0 min CN=WQ Runoff=0.34 cfs 0.027 af

**SubcatchmentPD1.3:** Runoff Area=3,754 sf 23.26% Impervious Runoff Depth=2.89"  
Flow Length=80' Slope=0.0100 '/' Tc=8.1 min CN=WQ Runoff=0.24 cfs 0.021 af

**Pond BMP:** Peak Elev=121.90' Storage=101 cf Inflow=2.15 cfs 0.175 af  
Discarded=0.01 cfs 0.015 af Primary=2.14 cfs 0.160 af Outflow=2.15 cfs 0.175 af

**Link DP1:** Inflow=2.71 cfs 0.209 af  
Primary=2.71 cfs 0.209 af

**Total Runoff Area = 0.507 ac Runoff Volume = 0.223 af Average Runoff Depth = 5.29"**  
**16.95% Pervious = 0.086 ac 83.05% Impervious = 0.421 ac**

**Summary for Subcatchment PD1.1:**

[47] Hint: Peak is 191% of capacity of segment #4

Runoff = 2.15 cfs @ 12.08 hrs, Volume= 0.175 af, Depth= 5.76"  
 Routed to Pond BMP :

Runoff by SCS TR-20 method, UH=SCS, Weighted-Q, Time Span= 0.00-72.00 hrs, dt= 0.01 hrs  
 Type III 24-hr 25-Year Rainfall=6.14"

Area (sf)	CN	Description
3,661	98	Roofs, HSG C
853	74	>75% Grass cover, Good, HSG C
11,360	98	Paved parking, HSG C
15,874		Weighted Average
853		5.37% Pervious Area
15,021		94.63% Impervious Area

Tc (min)	Length (feet)	Slope (ft/ft)	Velocity (ft/sec)	Capacity (cfs)	Description
0.9	50	0.0100	0.91		<b>Sheet Flow, A-B</b> Smooth surfaces n= 0.011 P2= 3.23"
0.5	81	0.0200	2.87		<b>Shallow Concentrated Flow, B-C</b> Paved Kv= 20.3 fps
0.7	143	0.0050	3.21	2.52	<b>Pipe Channel, C-D</b> 12.0" Round Area= 0.8 sf Perim= 3.1' r= 0.25' n= 0.013 Corrugated PE, smooth interior
0.2	20	0.0010	1.43	1.13	<b>Pipe Channel, D-E</b> 12.0" Round Area= 0.8 sf Perim= 3.1' r= 0.25' n= 0.013 Corrugated PE, smooth interior
0.1	17	0.0050	3.21	2.52	<b>Pipe Channel, E-F</b> 12.0" Round Area= 0.8 sf Perim= 3.1' r= 0.25' n= 0.013 Corrugated PE, smooth interior
2.4	311	Total, Increased to minimum Tc = 6.0 min			

**Summary for Subcatchment PD1.2:**

Runoff = 0.34 cfs @ 12.08 hrs, Volume= 0.027 af, Depth= 5.90"  
 Routed to Link DP1 :

Runoff by SCS TR-20 method, UH=SCS, Weighted-Q, Time Span= 0.00-72.00 hrs, dt= 0.01 hrs  
 Type III 24-hr 25-Year Rainfall=6.14"

Area (sf)	CN	Description
6	74	>75% Grass cover, Good, HSG C
2,432	98	Paved parking, HSG C
2,438		Weighted Average
6		0.25% Pervious Area
2,432		99.75% Impervious Area

Tc (min)	Length (feet)	Slope (ft/ft)	Velocity (ft/sec)	Capacity (cfs)	Description
1.0	50	0.0090	0.87		<b>Sheet Flow, A-B</b> Smooth surfaces n= 0.011 P2= 3.23"
1.5	172	0.0090	1.93		<b>Shallow Concentrated Flow, B-C</b> Paved Kv= 20.3 fps
2.5	222	Total, Increased to minimum Tc = 6.0 min			

**Summary for Subcatchment PD1.3:**

Runoff = 0.24 cfs @ 12.11 hrs, Volume= 0.021 af, Depth= 2.89"  
 Routed to Link DP1 :

Runoff by SCS TR-20 method, UH=SCS, Weighted-Q, Time Span= 0.00-72.00 hrs, dt= 0.01 hrs  
 Type III 24-hr 25-Year Rainfall=6.14"

Area (sf)	CN	Description
573	98	Paved parking, HSG C
1,539	74	>75% Grass cover, Good, HSG C
43	70	Woods, Good, HSG C
300	98	Paved parking, HSG A
964	39	>75% Grass cover, Good, HSG A
335	30	Woods, Good, HSG A
3,754		Weighted Average
2,881		76.74% Pervious Area
873		23.26% Impervious Area

Tc (min)	Length (feet)	Slope (ft/ft)	Velocity (ft/sec)	Capacity (cfs)	Description
7.4	50	0.0100	0.11		<b>Sheet Flow, A-B</b>
					Grass: Short n= 0.150 P2= 3.23"
0.7	30	0.0100	0.70		<b>Shallow Concentrated Flow, B-C</b>
					Short Grass Pasture Kv= 7.0 fps
8.1	80	Total			

**Summary for Pond BMP:**

Inflow Area = 0.364 ac, 94.63% Impervious, Inflow Depth = 5.76" for 25-Year event  
 Inflow = 2.15 cfs @ 12.08 hrs, Volume= 0.175 af  
 Outflow = 2.15 cfs @ 12.08 hrs, Volume= 0.175 af, Atten= 0%, Lag= 0.1 min  
 Discarded = 0.01 cfs @ 1.66 hrs, Volume= 0.015 af  
 Primary = 2.14 cfs @ 12.08 hrs, Volume= 0.160 af  
 Routed to Link DP1 :

Routing by Dyn-Stor-Ind method, Time Span= 0.00-72.00 hrs, dt= 0.01 hrs  
 Peak Elev= 121.90' @ 12.08 hrs Surf.Area= 120 sf Storage= 101 cf

Plug-Flow detention time= 15.6 min calculated for 0.175 af (100% of inflow)  
 Center-of-Mass det. time= 15.6 min ( 763.0 - 747.4 )

Volume	Invert	Avail.Storage	Storage Description
#1	119.90'	94 cf	<b>Custom Stage Data (Prismatic)</b> Listed below (Recalc) 252 cf Overall - 17 cf Embedded = 235 cf x 40.0% Voids
#2	120.40'	12 cf	<b>12.0" Round Pipe Storage</b> Inside #1 L= 15.0' 17 cf Overall - 1.2" Wall Thickness = 12 cf
		106 cf	Total Available Storage

Elevation (feet)	Surf.Area (sq-ft)	Inc.Store (cubic-feet)	Cum.Store (cubic-feet)
119.90	120	0	0
120.00	120	12	12
121.00	120	120	132
122.00	120	120	252

Device	Routing	Invert	Outlet Devices
#1	Primary	120.40'	<b>12.0" Round Culvert</b> L= 17.0' CPP, square edge headwall, Ke= 0.500 Inlet / Outlet Invert= 120.40' / 120.30' S= 0.0059 '/' Cc= 0.900 n= 0.013 Corrugated PE, smooth interior, Flow Area= 0.79 sf
#2	Device 1	121.60'	<b>4.0' long Sharp-Crested Rectangular Weir</b> 2 End Contraction(s)
#3	Discarded	119.90'	<b>2.410 in/hr Exfiltration over Surface area</b> Phase-In= 0.01'

**Discarded OutFlow** Max=0.01 cfs @ 1.66 hrs HW=119.92' (Free Discharge)  
 ↳ **3=Exfiltration** (Exfiltration Controls 0.01 cfs)

**Primary OutFlow** Max=2.14 cfs @ 12.08 hrs HW=121.90' TW=0.00' (Dynamic Tailwater)  
 ↳ **1=Culvert** (Passes 2.14 cfs of 3.43 cfs potential flow)  
 ↳ **2=Sharp-Crested Rectangular Weir**(Weir Controls 2.14 cfs @ 1.80 fps)

**Summary for Link DP1:**

Inflow Area = 0.507 ac, 83.05% Impervious, Inflow Depth = 4.94" for 25-Year event  
Inflow = 2.71 cfs @ 12.09 hrs, Volume= 0.209 af  
Primary = 2.71 cfs @ 12.09 hrs, Volume= 0.209 af, Atten= 0%, Lag= 0.0 min

Primary outflow = Inflow, Time Span= 0.00-72.00 hrs, dt= 0.01 hrs

Time span=0.00-72.00 hrs, dt=0.01 hrs, 7201 points  
Runoff by SCS TR-20 method, UH=SCS, Weighted-Q  
Reach routing by Dyn-Stor-Ind method - Pond routing by Dyn-Stor-Ind method

**SubcatchmentPD1.1:** Runoff Area=15,874 sf 94.63% Impervious Runoff Depth=7.48"  
Flow Length=311' Tc=6.0 min CN=WQ Runoff=2.77 cfs 0.227 af

**SubcatchmentPD1.2:** Runoff Area=2,438 sf 99.75% Impervious Runoff Depth=7.62"  
Flow Length=222' Slope=0.0090 '/' Tc=6.0 min CN=WQ Runoff=0.43 cfs 0.036 af

**SubcatchmentPD1.3:** Runoff Area=3,754 sf 23.26% Impervious Runoff Depth=4.11"  
Flow Length=80' Slope=0.0100 '/' Tc=8.1 min CN=WQ Runoff=0.35 cfs 0.030 af

**Pond BMP:** Peak Elev=121.96' Storage=104 cf Inflow=2.77 cfs 0.227 af  
Discarded=0.01 cfs 0.015 af Primary=2.77 cfs 0.212 af Outflow=2.77 cfs 0.227 af

**Link DP1:** Inflow=3.53 cfs 0.277 af  
Primary=3.53 cfs 0.277 af

**Total Runoff Area = 0.507 ac Runoff Volume = 0.292 af Average Runoff Depth = 6.92"**  
**16.95% Pervious = 0.086 ac 83.05% Impervious = 0.421 ac**

**Summary for Subcatchment PD1.1:**

[47] Hint: Peak is 110% of capacity of segment #3

[47] Hint: Peak is 246% of capacity of segment #4

[47] Hint: Peak is 110% of capacity of segment #5

Runoff = 2.77 cfs @ 12.08 hrs, Volume= 0.227 af, Depth= 7.48"  
 Routed to Pond BMP :

Runoff by SCS TR-20 method, UH=SCS, Weighted-Q, Time Span= 0.00-72.00 hrs, dt= 0.01 hrs  
 Type III 24-hr 100-Year Rainfall=7.87"

Area (sf)	CN	Description
3,661	98	Roofs, HSG C
853	74	>75% Grass cover, Good, HSG C
11,360	98	Paved parking, HSG C
15,874		Weighted Average
853		5.37% Pervious Area
15,021		94.63% Impervious Area

Tc (min)	Length (feet)	Slope (ft/ft)	Velocity (ft/sec)	Capacity (cfs)	Description
0.9	50	0.0100	0.91		<b>Sheet Flow, A-B</b> Smooth surfaces n= 0.011 P2= 3.23"
0.5	81	0.0200	2.87		<b>Shallow Concentrated Flow, B-C</b> Paved Kv= 20.3 fps
0.7	143	0.0050	3.21	2.52	<b>Pipe Channel, C-D</b> 12.0" Round Area= 0.8 sf Perim= 3.1' r= 0.25' n= 0.013 Corrugated PE, smooth interior
0.2	20	0.0010	1.43	1.13	<b>Pipe Channel, D-E</b> 12.0" Round Area= 0.8 sf Perim= 3.1' r= 0.25' n= 0.013 Corrugated PE, smooth interior
0.1	17	0.0050	3.21	2.52	<b>Pipe Channel, E-F</b> 12.0" Round Area= 0.8 sf Perim= 3.1' r= 0.25' n= 0.013 Corrugated PE, smooth interior
2.4	311	Total, Increased to minimum Tc = 6.0 min			

**Summary for Subcatchment PD1.2:**

Runoff = 0.43 cfs @ 12.08 hrs, Volume= 0.036 af, Depth= 7.62"  
 Routed to Link DP1 :

Runoff by SCS TR-20 method, UH=SCS, Weighted-Q, Time Span= 0.00-72.00 hrs, dt= 0.01 hrs  
 Type III 24-hr 100-Year Rainfall=7.87"

Area (sf)	CN	Description
6	74	>75% Grass cover, Good, HSG C
2,432	98	Paved parking, HSG C
2,438		Weighted Average
6		0.25% Pervious Area
2,432		99.75% Impervious Area

Tc (min)	Length (feet)	Slope (ft/ft)	Velocity (ft/sec)	Capacity (cfs)	Description
1.0	50	0.0090	0.87		<b>Sheet Flow, A-B</b> Smooth surfaces n= 0.011 P2= 3.23"
1.5	172	0.0090	1.93		<b>Shallow Concentrated Flow, B-C</b> Paved Kv= 20.3 fps
2.5	222	Total, Increased to minimum Tc = 6.0 min			

**Summary for Subcatchment PD1.3:**

Runoff = 0.35 cfs @ 12.11 hrs, Volume= 0.030 af, Depth= 4.11"  
 Routed to Link DP1 :

Runoff by SCS TR-20 method, UH=SCS, Weighted-Q, Time Span= 0.00-72.00 hrs, dt= 0.01 hrs  
 Type III 24-hr 100-Year Rainfall=7.87"

Area (sf)	CN	Description
573	98	Paved parking, HSG C
1,539	74	>75% Grass cover, Good, HSG C
43	70	Woods, Good, HSG C
300	98	Paved parking, HSG A
964	39	>75% Grass cover, Good, HSG A
335	30	Woods, Good, HSG A
3,754		Weighted Average
2,881		76.74% Pervious Area
873		23.26% Impervious Area

Tc (min)	Length (feet)	Slope (ft/ft)	Velocity (ft/sec)	Capacity (cfs)	Description
7.4	50	0.0100	0.11		<b>Sheet Flow, A-B</b>
					Grass: Short n= 0.150 P2= 3.23"
0.7	30	0.0100	0.70		<b>Shallow Concentrated Flow, B-C</b>
					Short Grass Pasture Kv= 7.0 fps
8.1	80	Total			

**Summary for Pond BMP:**

Inflow Area = 0.364 ac, 94.63% Impervious, Inflow Depth = 7.48" for 100-Year event  
 Inflow = 2.77 cfs @ 12.08 hrs, Volume= 0.227 af  
 Outflow = 2.77 cfs @ 12.08 hrs, Volume= 0.227 af, Atten= 0%, Lag= 0.1 min  
 Discarded = 0.01 cfs @ 1.16 hrs, Volume= 0.015 af  
 Primary = 2.77 cfs @ 12.08 hrs, Volume= 0.212 af

Routed to Link DP1 :

Routing by Dyn-Stor-Ind method, Time Span= 0.00-72.00 hrs, dt= 0.01 hrs  
 Peak Elev= 121.96' @ 12.08 hrs Surf.Area= 120 sf Storage= 104 cf

Plug-Flow detention time= 12.5 min calculated for 0.227 af (100% of inflow)  
 Center-of-Mass det. time= 12.5 min ( 756.6 - 744.0 )

Volume	Invert	Avail.Storage	Storage Description
#1	119.90'	94 cf	<b>Custom Stage Data (Prismatic)</b> Listed below (Recalc) 252 cf Overall - 17 cf Embedded = 235 cf x 40.0% Voids
#2	120.40'	12 cf	<b>12.0" Round Pipe Storage</b> Inside #1 L= 15.0' 17 cf Overall - 1.2" Wall Thickness = 12 cf
		106 cf	Total Available Storage

Elevation (feet)	Surf.Area (sq-ft)	Inc.Store (cubic-feet)	Cum.Store (cubic-feet)
119.90	120	0	0
120.00	120	12	12
121.00	120	120	132
122.00	120	120	252

Device	Routing	Invert	Outlet Devices
#1	Primary	120.40'	<b>12.0" Round Culvert</b> L= 17.0' CPP, square edge headwall, Ke= 0.500 Inlet / Outlet Invert= 120.40' / 120.30' S= 0.0059 '/' Cc= 0.900 n= 0.013 Corrugated PE, smooth interior, Flow Area= 0.79 sf
#2	Device 1	121.60'	<b>4.0' long Sharp-Crested Rectangular Weir</b> 2 End Contraction(s)
#3	Discarded	119.90'	<b>2.410 in/hr Exfiltration over Surface area</b> Phase-In= 0.01'

**Discarded OutFlow** Max=0.01 cfs @ 1.16 hrs HW=119.92' (Free Discharge)  
 ↳ **3=Exfiltration** (Exfiltration Controls 0.01 cfs)

**Primary OutFlow** Max=2.76 cfs @ 12.08 hrs HW=121.96' TW=0.00' (Dynamic Tailwater)  
 ↳ **1=Culvert** (Passes 2.76 cfs of 3.59 cfs potential flow)  
 ↳ **2=Sharp-Crested Rectangular Weir** (Weir Controls 2.76 cfs @ 1.96 fps)

**Summary for Link DP1:**

Inflow Area = 0.507 ac, 83.05% Impervious, Inflow Depth = 6.57" for 100-Year event  
Inflow = 3.53 cfs @ 12.09 hrs, Volume= 0.277 af  
Primary = 3.53 cfs @ 12.09 hrs, Volume= 0.277 af, Atten= 0%, Lag= 0.0 min

Primary outflow = Inflow, Time Span= 0.00-72.00 hrs, dt= 0.01 hrs

## **APPENDIX F: STORMWATER CALCULATIONS**

- MA STANDARD #3 – RECHARGE AND DRAWDOWN TIME
- MA STANDARD #4 – WATER QUALITY AND TSS REMOVAL
- NOAA RAINFALL DATA
- PIPE AND INLET SIZING
- OUTLET PROTECTION SIZING

Route 85 Realty - Fuel Station  
 166 Commonwealth Avenue  
 Concord, MA  
 Bohler Job Number: MAA250062.00  
 December 2, 2025

**MA DEP Standard 3: Recharge Volume Calculations**

<b>Required Recharge Volume - A Soils (0.60 in.)</b>	
Existing Site Impervious Area (ac)	0.021
Proposed Site Impervious Area (ac)	0.007
Proposed Increase in Site Impervious Area (ac)	-0.014
<b>Recharge Volume Required (cf)</b>	<b>0</b>

<b>Required Recharge Volume - B Soils (0.35 in.)</b>	
Existing Site Impervious Area (ac)	0.000
Proposed Site Impervious Area (ac)	0.000
Proposed Increase in Site Impervious Area (ac)	0.000
<b>Recharge Volume Required (cf)</b>	<b>0</b>

<b>Required Recharge Volume - C Soils (0.25 in.)</b>	
Existing Site Impervious Area (ac)	0.460
Proposed Site Impervious Area (ac)	0.414
Proposed Increase in Site Impervious Area (ac)	-0.046
<b>Recharge Volume Required (cf)</b>	<b>0</b>

<b>Required Recharge Volume - D Soils (0.10 in.)</b>	
Existing Site Impervious Area (ac)	0.000
Proposed Site Impervious Area (ac)	0.000
Proposed Increase in Site Impervious Area (ac)	0.000
<b>Recharge Volume Required (cf)</b>	<b>0</b>

<b>Total Recharge Volume Required (cf)</b>	<b>0</b>
--	----------

<b>Recharge Volume Adjustment Factor</b>	
Impervious Area Directed to Infiltration BMP (ac)	<b>0.345</b>
%Impervious Directed to Infiltration BMP	82%
Adjustment Factor	1.22
<b>Adjusted Total Recharge Volume Required (cf)</b>	<b>0</b>

<b>Provided Recharge Volume*</b>	
BMP	87
<b>Total Recharge Volume Provided (cf)</b>	<b>87</b>

**Provided greater than or Equal to Required**

\*Volume provided below lowest outlet in cubic feet (cf)

**Stage-Area-Storage for Pond BMP:**

Elevation (feet)	Surface (sq-ft)	Storage (cubic-feet)
119.90	<b>120</b>	0
119.95	120	2
120.00	120	5
120.05	120	7
120.10	120	10
120.15	120	12
120.20	120	14
120.25	120	17
120.30	120	19
120.35	120	22
120.40	120	24
120.45	120	26
120.50	120	29
120.55	120	31
120.60	120	34
120.65	120	37
120.70	120	39
120.75	120	42
120.80	120	45
120.85	120	48
120.90	120	50
120.95	120	53
121.00	120	56
121.05	120	59
121.10	120	62
121.15	120	64
121.20	120	67
121.25	120	70
121.30	120	72
121.35	120	75
121.40	120	77
121.45	120	79
121.50	120	82
121.55	120	84
<b>121.60</b>	<b>120</b>	<b>87</b>
121.65	120	89
121.70	120	91
121.75	120	94
121.80	120	96
121.85	120	99
121.90	120	101
121.95	120	103
122.00	120	<b>106</b>

weir elevation = 121.60  
volume = 87 cf

**Route 85 Realty - Fuel Station  
166 Commonwealth Avenue  
Concord, MA  
Bohler Job Number: MAA250062.00  
December 2, 2025**

**MA DEP Standard 3: Drawdown Time Calculations**

---

<b>Drawdown Time - BMP</b>	
Volume below outlet pipe (Rv) (cf)	87
Soil Type	Loamy Sand - A
Infiltration rate (K)*	2.41
Bottom Area (sf)	120
<b>Drawdown time (Hours)*</b>	<b>3.6</b>

\*Infiltration Rates taken from Rawls Table

\*\*Drawdown time =  $Rv / (K) \times (\text{bottom area})$

Prepared By:

**BOHLER** //  
50 Washington Street  
Westborough, MA 01581  
(508) 480-9900

12/2/2025

Route 85 Realty - Fuel Station  
 166 Commonwealth Avenue  
 Concord, MA  
 Bohler Job Number: MAA250062.00  
 12/2/2025

**1" Water Quality Volume to Flow Rate Calculation Sheet**

---

**Compute Water Quality Flow with the following Equation**

$WQF = (qu)(A)(WQV)$

Site Plan Callout	qu (from 1" - qu Table)	Impervious Area (SF)	Ai (sq/mi)	WQV (inches)		WQF (cfs)
WQU (A-30)	774	15021	0.000539	1	=	0.42

Water Quality Flow Rate = WQF  
 Water Quality Volume = WQV\*  
 Unit peak discharge (csm/in) = qu\*\*  
 Impervious Area in watershed (square miles) = Ai

\*WQV is expressed in watershed inches (you must use 1.0-inches in all cases with this method and not 0.5-inches)

\*\* calculate the qu based on the time of concentration (see 1" - qu Table)

Figure 4: for First 1-inch Runoff, Table of qu values for Ia/P Curve = 0.034, listed by tc, for Type III Storm Distribution

Tc (Hours)	qu (csm/in)	Tc (Hours)	qu (csm/in)	Tc (Hours)	qu (csm/in)
0.01	835	2.7	197	7.1	95
0.03	835	2.8	192	7.2	94
0.05	831	2.9	187	7.3	93
0.067	814	3	183	7.4	92
0.083	795	3.1	179	7.5	91
0.1	774	3.2	175	7.6	90
0.116	755	3.3	171	7.7	89
0.133	736	3.4	168	7.8	88
0.15	717	3.5	164	7.9	87
0.167	700	3.6	161	8	86
0.183	685	3.7	158	8.1	85
0.2	669	3.8	155	8.2	84
0.217	654	3.9	152	8.3	84
0.233	641	4	149	8.4	83
0.25	628	4.1	146	8.5	82
0.3	593	4.2	144	8.6	81
0.333	572	4.3	141	8.7	80
0.35	563	4.4	139	8.8	79
0.4	536	4.5	137	8.9	79
0.416	528	4.6	134	9	78
0.5	491	4.7	132	9.1	77
0.583	460	4.8	130	9.2	76
0.6	454	4.9	128	9.3	76
0.667	433	5	126	9.4	75
0.7	424	5.1	124	9.5	74
0.8	398	5.2	122	9.6	74
0.9	376	5.3	120	9.7	73
1	356	5.4	119	9.8	72
1.1	339	5.5	117	9.9	72
1.2	323	5.6	115	10	71
1.3	309	5.7	114		
1.4	296	5.8	112		
1.5	285	5.9	111		
1.6	274	6	109		
1.7	264	6.1	108		
1.8	255	6.2	106		
1.9	247	6.3	105		
2	239	6.4	104		
2.1	232	6.5	102		
2.2	225	6.6	101		
2.3	219	6.7	100		
2.4	213	6.8	99		
2.5	207	6.9	98		
2.6	202	7	96		

# Available Models

CDS Model	Treatment Capacity <sup>3</sup> (cfs)	Maximum Sediment Storage Capacity (CF)
1515	1.0	26
w/ 1' added sump	1.0	33
w/ 2' added sump	1.0	40
w/ 3' added sump	1.0	47
<b>2015_4</b>	<b>1.4</b>	<b>50</b>
w/ 1' added sump	1.4	63
w/ 2' added sump	1.4	75
w/ 3' added sump	1.4	88
2015	1.4	79
w/ 1' added sump	1.4	98
w/ 2' added sump	1.4	118
2020	2.2	90
w/ 1' added sump	2.2	110
w/ 2' added sump	2.2	129
2025	3.2	97
w/ 1' added sump	3.2	117
w/ 2' added sump	3.2	136
3020	3.9	134
w/ 1' added sump	3.9	163
w/ 2' added sump	3.9	191
3030	6.1	157
w/ 1' added sump	6.1	185
w/ 2' added sump	6.1	213
4030	7.9	329
w/ 1' added sump	7.9	379
w/ 2' added sump	7.9	429
4040	12.4	381
w/ 1' added sump	12.4	431
w/ 2' added sump	12.4	482

1. Structure diameter represents the typical inside dimension of the concrete structure. Offline systems will require additional concrete diversion components
2. Depth below pipe can vary to accommodate site specific design. Depth below pipe invert represents the depth from the pipe invert to the inside bottom of concrete structure.
3. Treatment Capacity is based on laboratory testing using OK-110 (average d50 particle size of approximately 100 microns) and a 2400 micron screen.

Sediment Depths Indicating Required Servicing*			
CDS Model	Standard Sediment Depth (in.)	w/ 1' added Sump Sediment Depth (in.)	w/ 2' added Sump Sediment Depth (in.)
1515	18	27	36
2015_4	18	30	42
2015	18	30	42
2020	18	30	42
2025	18	30	42
3020	18	30	42
3030	18	39	42
4030	27	39	51
4040	27	39	51

\* Based on 75% capacity of isolated sump.

Route 85 Realty - Fuel Station  
 166 Commonwealth Avenue  
 Concord, MA  
 Bohler Job Number: MAA250062.00  
 December 2, 2025

**MA DEP Standard 4: TSS Removal Calculation Worksheet**

---

BMP Treatment Train: Deep-Sump Hooded Catch Basins to Proprietary Water Quality Unit (A-30) to Infiltration Trench (BMP)

A BMP	B TSS Removal Rate	C Starting TSS Load*	D Amount Removed (B*C)	E Remaining Load (C-D)
Deep-Sump Hooded Catch Basins	0.25	1.00	0.25	0.75
Proprietary Water Quality Unit (A-30)	0.85	0.75	0.64	0.11
Infiltration Trench (BMP)	0.80	0.11	0.09	0.02
			<b>Total TSS Removal =</b>	<b>98%</b>

\*Equals remaining load from previous BMP (E) which enters BMP



**NOAA Atlas 14, Volume 10, Version 3**  
**Location name: Concord, Massachusetts, USA\***  
**Latitude: 42.4585°, Longitude: -71.397°**  
**Elevation: 126 ft\*\***  
 \* source: ESRI Maps  
 \*\* source: USGS



**POINT PRECIPITATION FREQUENCY ESTIMATES**

Sanja Perica, Sandra Pavlovic, Michael St. Laurent, Carl Trypaluk, Dale Unruh, Orlan Wilhite

NOAA, National Weather Service, Silver Spring, Maryland

[PF\\_tabular](#) | [PF\\_graphical](#) | [Maps\\_&\\_aerials](#)

**PF tabular**

<b>PDS-based point precipitation frequency estimates with 90% confidence intervals (in inches)<sup>1</sup></b>										
Duration	Average recurrence interval (years)									
	1	2	5	10	25	50	100	200	500	1000
<b>5-min</b>	<b>0.316</b> (0.244-0.403)	<b>0.383</b> (0.294-0.488)	<b>0.492</b> (0.377-0.629)	<b>0.582</b> (0.443-0.748)	<b>0.705</b> (0.522-0.947)	<b>0.797</b> (0.580-1.09)	<b>0.895</b> (0.636-1.28)	<b>1.01</b> (0.678-1.46)	<b>1.18</b> (0.764-1.77)	<b>1.33</b> (0.840-2.02)
<b>10-min</b>	<b>0.448</b> (0.345-0.571)	<b>0.542</b> (0.417-0.691)	<b>0.696</b> (0.533-0.889)	<b>0.823</b> (0.627-1.06)	<b>0.998</b> (0.740-1.34)	<b>1.13</b> (0.822-1.55)	<b>1.27</b> (0.901-1.81)	<b>1.43</b> (0.960-2.07)	<b>1.68</b> (1.08-2.50)	<b>1.88</b> (1.19-2.86)
<b>15-min</b>	<b>0.527</b> (0.406-0.672)	<b>0.638</b> (0.490-0.813)	<b>0.819</b> (0.627-1.05)	<b>0.968</b> (0.738-1.24)	<b>1.17</b> (0.870-1.58)	<b>1.33</b> (0.967-1.82)	<b>1.49</b> (1.06-2.13)	<b>1.68</b> (1.13-2.44)	<b>1.97</b> (1.28-2.94)	<b>2.21</b> (1.40-3.36)
<b>30-min</b>	<b>0.718</b> (0.553-0.915)	<b>0.870</b> (0.669-1.11)	<b>1.12</b> (0.857-1.43)	<b>1.32</b> (1.01-1.70)	<b>1.61</b> (1.19-2.16)	<b>1.82</b> (1.32-2.50)	<b>2.04</b> (1.45-2.91)	<b>2.31</b> (1.55-3.34)	<b>2.70</b> (1.75-4.04)	<b>3.04</b> (1.92-4.62)
<b>60-min</b>	<b>0.909</b> (0.700-1.16)	<b>1.10</b> (0.847-1.40)	<b>1.42</b> (1.09-1.81)	<b>1.68</b> (1.28-2.16)	<b>2.04</b> (1.51-2.74)	<b>2.31</b> (1.68-3.17)	<b>2.59</b> (1.84-3.70)	<b>2.93</b> (1.97-4.24)	<b>3.44</b> (2.22-5.13)	<b>3.86</b> (2.44-5.87)
<b>2-hr</b>	<b>1.16</b> (0.901-1.46)	<b>1.42</b> (1.10-1.79)	<b>1.84</b> (1.43-2.34)	<b>2.20</b> (1.69-2.80)	<b>2.68</b> (2.01-3.58)	<b>3.04</b> (2.24-4.15)	<b>3.43</b> (2.47-4.88)	<b>3.91</b> (2.63-5.60)	<b>4.64</b> (3.01-6.87)	<b>5.28</b> (3.35-7.96)
<b>3-hr</b>	<b>1.34</b> (1.05-1.68)	<b>1.65</b> (1.28-2.07)	<b>2.14</b> (1.67-2.70)	<b>2.56</b> (1.98-3.24)	<b>3.12</b> (2.35-4.16)	<b>3.54</b> (2.62-4.82)	<b>4.00</b> (2.89-5.68)	<b>4.57</b> (3.08-6.51)	<b>5.46</b> (3.55-8.03)	<b>6.23</b> (3.96-9.33)
<b>6-hr</b>	<b>1.72</b> (1.36-2.15)	<b>2.11</b> (1.66-2.63)	<b>2.75</b> (2.16-3.44)	<b>3.28</b> (2.56-4.12)	<b>4.00</b> (3.03-5.27)	<b>4.54</b> (3.38-6.11)	<b>5.12</b> (3.73-7.20)	<b>5.85</b> (3.97-8.25)	<b>6.98</b> (4.56-10.2)	<b>7.97</b> (5.09-11.8)
<b>12-hr</b>	<b>2.20</b> (1.75-2.71)	<b>2.68</b> (2.13-3.30)	<b>3.47</b> (2.74-4.29)	<b>4.12</b> (3.24-5.13)	<b>5.02</b> (3.84-6.55)	<b>5.69</b> (4.26-7.58)	<b>6.41</b> (4.68-8.90)	<b>7.30</b> (4.98-10.2)	<b>8.67</b> (5.68-12.5)	<b>9.85</b> (6.30-14.5)
<b>24-hr</b>	<b>2.63</b> (2.11-3.21)	<b>3.23</b> (2.59-3.95)	<b>4.21</b> (3.36-5.16)	<b>5.02</b> (3.99-6.19)	<b>6.14</b> (4.73-7.94)	<b>6.97</b> (5.26-9.20)	<b>7.87</b> (5.79-10.8)	<b>8.98</b> (6.15-12.4)	<b>10.7</b> (7.03-15.3)	<b>12.2</b> (7.81-17.7)
<b>2-day</b>	<b>2.98</b> (2.41-3.60)	<b>3.71</b> (3.00-4.49)	<b>4.90</b> (3.95-5.95)	<b>5.90</b> (4.72-7.20)	<b>7.26</b> (5.64-9.32)	<b>8.27</b> (6.30-10.9)	<b>9.37</b> (6.96-12.8)	<b>10.8</b> (7.40-14.8)	<b>13.0</b> (8.56-18.4)	<b>14.9</b> (9.60-21.5)
<b>3-day</b>	<b>3.25</b> (2.65-3.91)	<b>4.04</b> (3.28-4.86)	<b>5.32</b> (4.31-6.42)	<b>6.39</b> (5.14-7.75)	<b>7.85</b> (6.13-10.0)	<b>8.93</b> (6.83-11.7)	<b>10.1</b> (7.55-13.8)	<b>11.6</b> (8.02-15.8)	<b>14.0</b> (9.27-19.7)	<b>16.1</b> (10.4-23.1)
<b>4-day</b>	<b>3.51</b> (2.87-4.20)	<b>4.32</b> (3.53-5.18)	<b>5.65</b> (4.60-6.79)	<b>6.75</b> (5.46-8.16)	<b>8.27</b> (6.47-10.5)	<b>9.38</b> (7.20-12.2)	<b>10.6</b> (7.93-14.4)	<b>12.2</b> (8.40-16.5)	<b>14.6</b> (9.69-20.5)	<b>16.8</b> (10.8-23.9)
<b>7-day</b>	<b>4.25</b> (3.50-5.04)	<b>5.09</b> (4.19-6.05)	<b>6.47</b> (5.30-7.72)	<b>7.62</b> (6.20-9.13)	<b>9.19</b> (7.24-11.5)	<b>10.3</b> (7.98-13.3)	<b>11.6</b> (8.71-15.6)	<b>13.2</b> (9.18-17.8)	<b>15.7</b> (10.5-21.8)	<b>17.9</b> (11.6-25.3)
<b>10-day</b>	<b>4.93</b> (4.08-5.82)	<b>5.79</b> (4.79-6.85)	<b>7.21</b> (5.94-8.56)	<b>8.39</b> (6.86-10.0)	<b>10.0</b> (7.90-12.5)	<b>11.2</b> (8.65-14.3)	<b>12.5</b> (9.36-16.6)	<b>14.1</b> (9.81-18.8)	<b>16.5</b> (11.0-22.8)	<b>18.7</b> (12.1-26.2)
<b>20-day</b>	<b>6.90</b> (5.77-8.08)	<b>7.84</b> (6.55-9.19)	<b>9.38</b> (7.80-11.0)	<b>10.7</b> (8.79-12.6)	<b>12.4</b> (9.85-15.2)	<b>13.7</b> (10.6-17.2)	<b>15.1</b> (11.3-19.5)	<b>16.6</b> (11.7-22.0)	<b>18.8</b> (12.6-25.7)	<b>20.6</b> (13.4-28.6)
<b>30-day</b>	<b>8.54</b> (7.18-9.94)	<b>9.54</b> (8.01-11.1)	<b>11.2</b> (9.34-13.1)	<b>12.5</b> (10.4-14.7)	<b>14.4</b> (11.5-17.5)	<b>15.8</b> (12.3-19.6)	<b>17.3</b> (12.8-22.0)	<b>18.8</b> (13.2-24.6)	<b>20.8</b> (14.0-28.1)	<b>22.3</b> (14.5-30.8)
<b>45-day</b>	<b>10.6</b> (8.96-12.3)	<b>11.7</b> (9.86-13.5)	<b>13.4</b> (11.3-15.6)	<b>14.9</b> (12.4-17.4)	<b>16.9</b> (13.5-20.3)	<b>18.5</b> (14.3-22.6)	<b>20.0</b> (14.8-25.1)	<b>21.4</b> (15.2-27.9)	<b>23.3</b> (15.7-31.3)	<b>24.6</b> (16.1-33.8)
<b>60-day</b>	<b>12.3</b> (10.5-14.2)	<b>13.5</b> (11.4-15.5)	<b>15.3</b> (12.9-17.7)	<b>16.9</b> (14.1-19.6)	<b>19.0</b> (15.2-22.7)	<b>20.6</b> (16.1-25.1)	<b>22.2</b> (16.5-27.7)	<b>23.7</b> (16.8-30.7)	<b>25.5</b> (17.2-34.1)	<b>26.7</b> (17.4-36.5)

<sup>1</sup> Precipitation frequency (PF) estimates in this table are based on frequency analysis of partial duration series (PDS).  
 Numbers in parenthesis are PF estimates at lower and upper bounds of the 90% confidence interval. The probability that precipitation frequency estimates (for a given duration and average recurrence interval) will be greater than the upper bound (or less than the lower bound) is 5%. Estimates at upper bounds are not checked against probable maximum precipitation (PMP) estimates and may be higher than currently valid PMP values.  
 Please refer to NOAA Atlas 14 document for more information.

[Back to Top](#)

**PF graphical**



**NOAA Atlas 14, Volume 10, Version 3**  
**Location name: Concord, Massachusetts, USA\***  
**Latitude: 42.4585°, Longitude: -71.397°**  
**Elevation: 126 ft\*\***  
 \* source: ESRI Maps  
 \*\* source: USGS



**POINT PRECIPITATION FREQUENCY ESTIMATES**

Sanja Perica, Sandra Pavlovic, Michael St. Laurent, Carl Trypaluk, Dale Unruh, Orlan Wilhite

NOAA, National Weather Service, Silver Spring, Maryland

[PF\\_tabular](#) | [PF\\_graphical](#) | [Maps\\_&\\_aerials](#)

**PF tabular**

<b>PDS-based point precipitation frequency estimates with 90% confidence intervals (in inches/hour)<sup>1</sup></b>										
<b>Duration</b>	<b>Average recurrence interval (years)</b>									
	<b>1</b>	<b>2</b>	<b>5</b>	<b>10</b>	<b>25</b>	<b>50</b>	<b>100</b>	<b>200</b>	<b>500</b>	<b>1000</b>
<b>5-min</b>	<b>3.79</b> (2.93-4.84)	<b>4.60</b> (3.53-5.86)	<b>5.90</b> (4.52-7.55)	<b>6.98</b> (5.32-8.98)	<b>8.46</b> (6.26-11.4)	<b>9.56</b> (6.96-13.1)	<b>10.7</b> (7.63-15.3)	<b>12.1</b> (8.14-17.5)	<b>14.2</b> (9.17-21.2)	<b>15.9</b> (10.1-24.2)
<b>10-min</b>	<b>2.69</b> (2.07-3.43)	<b>3.25</b> (2.50-4.15)	<b>4.18</b> (3.20-5.33)	<b>4.94</b> (3.76-6.35)	<b>5.99</b> (4.44-8.05)	<b>6.77</b> (4.93-9.30)	<b>7.61</b> (5.41-10.8)	<b>8.59</b> (5.76-12.4)	<b>10.0</b> (6.50-15.0)	<b>11.3</b> (7.14-17.2)
<b>15-min</b>	<b>2.11</b> (1.62-2.69)	<b>2.55</b> (1.96-3.25)	<b>3.28</b> (2.51-4.19)	<b>3.87</b> (2.95-4.98)	<b>4.70</b> (3.48-6.31)	<b>5.31</b> (3.87-7.29)	<b>5.97</b> (4.24-8.51)	<b>6.74</b> (4.52-9.74)	<b>7.88</b> (5.10-11.8)	<b>8.85</b> (5.60-13.5)
<b>30-min</b>	<b>1.44</b> (1.11-1.83)	<b>1.74</b> (1.34-2.22)	<b>2.24</b> (1.71-2.86)	<b>2.65</b> (2.02-3.40)	<b>3.21</b> (2.38-4.32)	<b>3.63</b> (2.65-4.99)	<b>4.09</b> (2.90-5.83)	<b>4.62</b> (3.10-6.67)	<b>5.41</b> (3.50-8.07)	<b>6.07</b> (3.84-9.24)
<b>60-min</b>	<b>0.909</b> (0.700-1.16)	<b>1.10</b> (0.847-1.40)	<b>1.42</b> (1.09-1.81)	<b>1.68</b> (1.28-2.16)	<b>2.04</b> (1.51-2.74)	<b>2.31</b> (1.68-3.17)	<b>2.59</b> (1.84-3.70)	<b>2.93</b> (1.97-4.24)	<b>3.44</b> (2.22-5.13)	<b>3.86</b> (2.44-5.87)
<b>2-hr</b>	<b>0.580</b> (0.450-0.732)	<b>0.710</b> (0.551-0.897)	<b>0.922</b> (0.713-1.17)	<b>1.10</b> (0.844-1.40)	<b>1.34</b> (1.00-1.79)	<b>1.52</b> (1.12-2.08)	<b>1.71</b> (1.23-2.44)	<b>1.95</b> (1.31-2.80)	<b>2.32</b> (1.51-3.44)	<b>2.64</b> (1.68-3.98)
<b>3-hr</b>	<b>0.446</b> (0.348-0.560)	<b>0.548</b> (0.427-0.688)	<b>0.713</b> (0.555-0.900)	<b>0.851</b> (0.657-1.08)	<b>1.04</b> (0.782-1.38)	<b>1.18</b> (0.872-1.60)	<b>1.33</b> (0.963-1.89)	<b>1.52</b> (1.03-2.17)	<b>1.82</b> (1.18-2.67)	<b>2.08</b> (1.32-3.11)
<b>6-hr</b>	<b>0.288</b> (0.226-0.358)	<b>0.353</b> (0.277-0.439)	<b>0.459</b> (0.360-0.573)	<b>0.547</b> (0.426-0.687)	<b>0.668</b> (0.506-0.880)	<b>0.757</b> (0.563-1.02)	<b>0.855</b> (0.622-1.20)	<b>0.976</b> (0.662-1.38)	<b>1.17</b> (0.761-1.70)	<b>1.33</b> (0.849-1.97)
<b>12-hr</b>	<b>0.182</b> (0.145-0.224)	<b>0.222</b> (0.176-0.274)	<b>0.287</b> (0.227-0.356)	<b>0.342</b> (0.269-0.425)	<b>0.417</b> (0.318-0.543)	<b>0.472</b> (0.353-0.629)	<b>0.532</b> (0.388-0.738)	<b>0.606</b> (0.413-0.846)	<b>0.719</b> (0.471-1.04)	<b>0.817</b> (0.522-1.20)
<b>24-hr</b>	<b>0.109</b> (0.088-0.133)	<b>0.134</b> (0.107-0.164)	<b>0.175</b> (0.140-0.215)	<b>0.209</b> (0.166-0.257)	<b>0.256</b> (0.197-0.330)	<b>0.290</b> (0.219-0.383)	<b>0.327</b> (0.241-0.451)	<b>0.374</b> (0.256-0.517)	<b>0.445</b> (0.292-0.636)	<b>0.507</b> (0.325-0.737)
<b>2-day</b>	<b>0.061</b> (0.050-0.074)	<b>0.077</b> (0.062-0.093)	<b>0.102</b> (0.082-0.124)	<b>0.122</b> (0.098-0.149)	<b>0.151</b> (0.117-0.194)	<b>0.172</b> (0.131-0.226)	<b>0.195</b> (0.145-0.267)	<b>0.224</b> (0.154-0.307)	<b>0.270</b> (0.178-0.382)	<b>0.310</b> (0.199-0.446)
<b>3-day</b>	<b>0.045</b> (0.036-0.054)	<b>0.056</b> (0.045-0.067)	<b>0.073</b> (0.059-0.089)	<b>0.088</b> (0.071-0.107)	<b>0.109</b> (0.085-0.139)	<b>0.124</b> (0.094-0.161)	<b>0.140</b> (0.104-0.191)	<b>0.161</b> (0.111-0.220)	<b>0.194</b> (0.128-0.273)	<b>0.223</b> (0.144-0.320)
<b>4-day</b>	<b>0.036</b> (0.029-0.043)	<b>0.045</b> (0.036-0.053)	<b>0.058</b> (0.047-0.070)	<b>0.070</b> (0.056-0.084)	<b>0.086</b> (0.067-0.109)	<b>0.097</b> (0.074-0.126)	<b>0.110</b> (0.082-0.149)	<b>0.126</b> (0.087-0.171)	<b>0.152</b> (0.100-0.213)	<b>0.174</b> (0.113-0.249)
<b>7-day</b>	<b>0.025</b> (0.020-0.030)	<b>0.030</b> (0.024-0.036)	<b>0.038</b> (0.031-0.045)	<b>0.045</b> (0.036-0.054)	<b>0.054</b> (0.043-0.068)	<b>0.061</b> (0.047-0.079)	<b>0.069</b> (0.051-0.092)	<b>0.078</b> (0.054-0.105)	<b>0.093</b> (0.062-0.129)	<b>0.106</b> (0.069-0.150)
<b>10-day</b>	<b>0.020</b> (0.016-0.024)	<b>0.024</b> (0.019-0.028)	<b>0.030</b> (0.024-0.035)	<b>0.034</b> (0.028-0.041)	<b>0.041</b> (0.032-0.051)	<b>0.046</b> (0.036-0.059)	<b>0.052</b> (0.039-0.069)	<b>0.058</b> (0.040-0.078)	<b>0.068</b> (0.045-0.095)	<b>0.077</b> (0.050-0.109)
<b>20-day</b>	<b>0.014</b> (0.012-0.016)	<b>0.016</b> (0.013-0.019)	<b>0.019</b> (0.016-0.022)	<b>0.022</b> (0.018-0.026)	<b>0.025</b> (0.020-0.031)	<b>0.028</b> (0.022-0.035)	<b>0.031</b> (0.023-0.040)	<b>0.034</b> (0.024-0.045)	<b>0.039</b> (0.026-0.053)	<b>0.042</b> (0.027-0.059)
<b>30-day</b>	<b>0.011</b> (0.009-0.013)	<b>0.013</b> (0.011-0.015)	<b>0.015</b> (0.012-0.018)	<b>0.017</b> (0.014-0.020)	<b>0.019</b> (0.015-0.024)	<b>0.021</b> (0.017-0.027)	<b>0.023</b> (0.017-0.030)	<b>0.026</b> (0.018-0.034)	<b>0.028</b> (0.019-0.039)	<b>0.030</b> (0.020-0.042)
<b>45-day</b>	<b>0.009</b> (0.008-0.011)	<b>0.010</b> (0.009-0.012)	<b>0.012</b> (0.010-0.014)	<b>0.013</b> (0.011-0.016)	<b>0.015</b> (0.012-0.018)	<b>0.017</b> (0.013-0.020)	<b>0.018</b> (0.013-0.023)	<b>0.019</b> (0.014-0.025)	<b>0.021</b> (0.014-0.028)	<b>0.022</b> (0.014-0.031)
<b>60-day</b>	<b>0.008</b> (0.007-0.009)	<b>0.009</b> (0.007-0.010)	<b>0.010</b> (0.008-0.012)	<b>0.011</b> (0.009-0.013)	<b>0.013</b> (0.010-0.015)	<b>0.014</b> (0.011-0.017)	<b>0.015</b> (0.011-0.019)	<b>0.016</b> (0.011-0.021)	<b>0.017</b> (0.011-0.023)	<b>0.018</b> (0.012-0.025)

<sup>1</sup> Precipitation frequency (PF) estimates in this table are based on frequency analysis of partial duration series (PDS). Numbers in parenthesis are PF estimates at lower and upper bounds of the 90% confidence interval. The probability that precipitation frequency estimates (for a given duration and average recurrence interval) will be greater than the upper bound (or less than the lower bound) is 5%. Estimates at upper bounds are not checked against probable maximum precipitation (PMP) estimates and may be higher than currently valid PMP values. Please refer to NOAA Atlas 14 document for more information.

[Back to Top](#)

**PF graphical**



## **APPENDIX G: OPERATION AND MAINTENANCE**

- STORMWATER OPERATION AND MAINTENANCE PLAN
- INSPECTION REPORT
- INSPECTION AND MAINTENANCE LOG FORM
- LONG-TERM POLLUTION PREVENTION PLAN
- ILLICIT DISCHARGE STATEMENT
- SPILL PREVENTION
- PROPOSED OPERATION AND MAINTENANCE MAP
- MANUFACTURER'S INSPECTION AND MAINTENANCE MANUALS

# **STORMWATER OPERATION AND MAINTENANCE PLAN**

***Concord Country Store LLC  
166 Commonwealth Avenue  
Concord, MA***

## **RESPONSIBLE PARTY DURING CONSTRUCTION:**

***Concord Country Store LLC  
8 Uxbridge Road  
Mendon, MA 01756***

## **RESPONSIBLE PARTY POST CONSTRUCTION:**

***Concord Country Store LLC  
8 Uxbridge Road  
Mendon, MA 01756***

### **Construction Phase**

During the construction phase, all erosion control devices and measures shall be maintained in accordance with the final record plans, local/state approvals and conditions, the EPA Construction General Permit and the Stormwater Pollution Prevention Plan (SWPPP) if applicable. Additionally, the maintenance of all erosion / siltation control measures during construction shall be the responsibility of the general contractor. Contact information of the OWNER and CONTRACTOR shall be listed in the SWPPP for this site. The SWPPP also includes information regarding construction period allowable and illicit discharges, housekeeping and emergency response procedures. Upon proper notice to the property owner, the Town/City or its authorized designee shall be allowed to enter the property at a reasonable time and in a reasonable manner for the purposes of inspection.

### **Post Development Controls**

Once construction is completed, the post development stormwater controls are to be operated and maintained in compliance with the following permanent procedures (note that the continued implementation of these procedures shall be the responsibility of the Owner or its assignee):

1. Parking lots: Sweep at least two (2) times per year and on a more frequent basis depending on sanding operations. Swept areas shall include all parking, drive aisles, and access aisles. All resulting sweepings shall be collected and properly disposed of offsite in accordance with MADEP and other applicable requirements.

Approximate Maintenance Budget: \$1,000/year

2. Catch basins, yard drains, trench drains, manholes and piping: Inspect two (2) times per year and at the end of foliage and snow-removal seasons. These features shall be cleaned two (2) times per year or whenever the depth of deposits is greater than or equal to one half the depth from the bottom of the invert of the lowest pipe in the catch basin or underground system. Accumulated sediment and hydrocarbons present must be removed

and properly disposed of off-site in accordance with MADEP and other applicable requirements.

Approximate Maintenance Budget: \$500/year per structure.

3. Riprap apron / Scour Hole: Riprap and scour holes should be checked at least annually and after every major storm event (generally equal or greater to 3.0 inches in 24 hours) for displaced stones, slumping, and erosion at edges, especially downstream or downslope. If the riprap is damaged, it should be repaired before further damage can take place. Note and repair any erosion, stone displacement or low spots in the areas. Woody vegetation should be removed from the riprap annually.

Approximate Maintenance Budget: \$250/year per location.

4. Water Quality Unit (Proprietary Separator): Follow manufacturer's recommendations (attached).

Approximate Maintenance Budget: \$1,000/year per unit.

All components of the stormwater system will be accessible by the owner or their assignee.

**STORMWATER MANAGEMENT SYSTEM**  
**POST-CONSTRUCTION INSPECTION REPORT**

**LOCATION:**

**Concord Country Store LLC  
166 Commonwealth Avenue  
Concord, MA**

**RESPONSIBLE PARTY:**

**Concord Country Store LLC  
8 Uxbridge Road  
Mendon, MA 01756**

NAME OF INSPECTOR:	INSPECTION DATE:
Note Condition of the Following (sediment depth, debris, standing water, damage, etc.):	
Catch Basins:	
Discharge Points/ Flared End Sections / Rip Rap:	
Infiltration Trench:	
Water Quality Units:	
Other:	

Note Recommended Actions to be taken on the Following (sediment and/or debris removal, repairs, etc.):

Catch Basins:

Discharge Points / Flared End Sections / Rip Rap:

Infiltration Trench:

Water Quality Units:

Other:

Comments:



## **LONG-TERM POLLUTION PREVENTION PLAN**

***Concord Country Store LLC  
166 Commonwealth Avenue  
Concord, MA***

### **RESPONSIBLE PARTY DURING CONSTRUCTION:**

***Concord Country Store LLC  
8 Uxbridge Road  
Mendon, MA 01756***

### **RESPONSIBLE PARTY POST CONSTRUCTION:**

***Concord Country Store LLC  
8 Uxbridge Road  
Mendon, MA 01756***

For this site, the Long-Term Pollution Prevention Plan will consist of the following:

- The property owner shall be responsible for “good housekeeping” including proper periodic maintenance of building and pavement areas, curbing, landscaping, etc.
- Proper storage and removal of solid waste (dumpsters).
- Sweeping of parking lots, drive aisles and access aisles a minimum of twice per year with a commercial cleaning unit. Any sediment removed shall be disposed of in accordance with applicable local and state requirements.
- Regular inspections and maintenance of Stormwater Management System as noted in the “O&M Plan”.
- Snow removal shall be the responsibility of the property owner. Snow shall not be plowed, dumped and/or placed in forebays, infiltration basins or similar stormwater controls. Salting and/or sanding of pavement / walkway areas during winter conditions shall only be done in accordance with all state/local requirements and approvals.
- Trash and other debris shall be removed from all areas of the site at least twice yearly.

## **OPERATON AND MAINTENANCE TRAINING PROGRAM**

The Owner will coordinate an annual in-house training session to discuss the Operations and Maintenance Plan, the Long-Term Pollution Prevention Plan, and the Spill Prevention Plan and response procedures. Annual training will include the following:

### **Discuss the Operations and Maintenance Plan:**

- Explain the general operations of the stormwater management system and its BMPs
- Identify potential sources of stormwater pollution and measures / methods of reducing or eliminating that pollution
- Emphasize good housekeeping measures

### **Discuss the Spill Prevention and Response Procedures:**

- Explain the process in the event of a spill
- Identify potential sources of spills and procedures for cleanup and /or reporting and notification
- Complete a yearly inventory or Materials Safety Data sheets of all tenants and confirm that no potentially harmful chemicals are in use.

## **ILLICIT DISCHARGE STATEMENT**

Certain types of non-stormwater discharges are allowed under the U.S. Environmental Protection Agency Construction General Permit. These types of discharges will be allowed under the conditions that no pollutants will be allowed to come in contact with the water prior to or after its discharge. The control measures which have been outlined previously in this LTPPP will be strictly followed to ensure that no contamination of these non-storm water discharges takes place. Any existing illicit discharges, if discovered during the course of the work, will be reported to MassDEP and the local DPW, as applicable, to be addressed in accordance with their respective policies. No illicit discharges will be allowed in conjunction with the proposed improvements.

Duly Acknowledged:

---

Name & Title	Date
--------------	------

## **SPILL PREVENTION AND RESPONSE PROCEDURES** **(POST CONSTRUCTION)**

In order to prevent or minimize the potential for a spill of Hazardous Substances or Oil or come into contact with stormwater, the following steps will be implemented:

1. All Hazardous Substances or Oil (such as pesticides, petroleum products, fertilizers, detergents, acids, paints, paint solvents, cleaning solvents, etc.) will be stored in a secure location, with their lids on, preferably under cover, when not in use.
2. The minimum practical quantity of all such materials will be kept on site.
3. A spill control and containment kit (containing, for example, absorbent materials, acid neutralizing powder, brooms, dust pans, mops, rags, gloves, goggles, plastic and metal trash containers, etc.) will be provided on site.
4. Manufacturer's recommended methods for spill cleanup will be clearly posted and site personnel will be trained regarding these procedures and the location of the information and cleanup supplies.
5. It is the OWNER's responsibility to ensure that all Hazardous Waste on site is disposed of properly by a licensed hazardous material disposal company. The OWNER is responsible for not exceeding Hazardous Waste storage requirements mandated by the EPA or state and local authorities.

In the event of a spill of Hazardous Substances or Oil, the following procedures should be followed:

1. All measures should be taken to contain and abate the spill and to prevent the discharge of the Hazardous Substance or Oil to stormwater or off-site. (The spill area should be kept well ventilated and personnel should wear appropriate protective clothing to prevent injury from contact with the Hazardous Substances.)
2. For spills of less than five (5) gallons of material, proceed with source control and containment, clean-up with absorbent materials or other applicable means unless an imminent hazard or other circumstances dictate that the spill should be treated by a professional emergency response contractor.
3. For spills greater than five (5) gallons of material immediately contact the MADEP at the toll-free 24-hour statewide emergency number: **1-888-304-1133**, the local fire department (**9-1-1**) and an approved emergency response contractor. Provide information on the type of material spilled, the location of the spill, the quantity spilled, and the time of the spill to the emergency response contractor or coordinator, and proceed with prevention, containment and/or clean-up if so desired. (Use the form provided, or similar).
4. If there is a Reportable Quantity (RQ) release, then the National Response Center should be notified immediately at (800) 424-8802; within 14 days a report should be submitted to the EPA regional office describing the release, the date and circumstances of the release and the steps taken to prevent another release. This Pollution Prevention Plan should be updated to reflect any such steps or actions taken and measures to prevent the same from reoccurring.



Cause of Spill: \_\_\_\_\_  
\_\_\_\_\_

Measures Taken to Clean up Spill: \_\_\_\_\_  
\_\_\_\_\_

Type of equipment: \_\_\_\_\_ Make: \_\_\_\_\_ Size: \_\_\_\_\_

License or S/N: \_\_\_\_\_

Location and Method of Disposal \_\_\_\_\_  
\_\_\_\_\_

Procedures, method, and precautions instituted to prevent a similar occurrence from recurring: \_\_\_\_\_  
\_\_\_\_\_  
\_\_\_\_\_

Additional Contact Numbers:

- DEPARTMENT OF ENVIRONMENTAL PROTECTION (DEP) EMERGENCY PHONE: 1-888-304-1133
- NATIONAL RESPONSE CENTER PHONE: (800) 424-8802
- U.S. ENVIRONMENTAL PROTECTION AGENCY PHONE: (888) 372-7341

# CDS Guide

## Operation, Design, Performance and Maintenance



## CDS®

Using patented continuous deflective separation technology, the CDS system screens, separates and traps debris, sediment, and oil and grease from stormwater runoff. The indirect screening capability of the system allows for 100% removal of floatables and neutrally buoyant material without blinding. Flow and screening controls physically separate captured solids, and minimize the re-suspension and release of previously trapped pollutants. Inline units can treat up to 6 cfs, and internally bypass flows in excess of 50 cfs (1416 L/s). Available precast or cast-in-place, offline units can treat flows from 1 to 300 cfs (28.3 to 8495 L/s). The pollutant removal capacity of the CDS system has been proven in lab and field testing.

## Operation Overview

Stormwater enters the diversion chamber where the diversion weir guides the flow into the unit's separation chamber and pollutants are removed from the flow. All flows up to the system's treatment design capacity enter the separation chamber and are treated.

Swirl concentration and screen deflection force floatables and solids to the center of the separation chamber where 100% of floatables and neutrally buoyant debris larger than the screen apertures are trapped.

Stormwater then moves through the separation screen, under the oil baffle and exits the system. The separation screen remains clog free due to continuous deflection.

During the flow events exceeding the treatment design capacity, the diversion weir bypasses excessive flows around the separation chamber, so captured pollutants are retained in the separation cylinder.

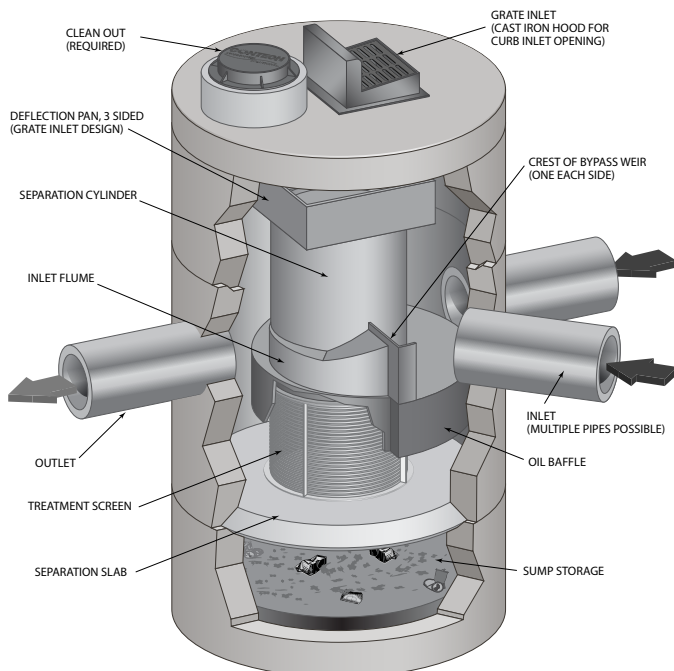

## Design Basics

There are three primary methods of sizing a CDS system. The Water Quality Flow Rate Method determines which model size provides the desired removal efficiency at a given flow rate for a defined particle size. The Rational Rainfall Method™ or the Probabilistic Method is used when a specific removal efficiency of the net annual sediment load is required.

Typically in the United States, CDS systems are designed to achieve an 80% annual solids load reduction based on lab generated performance curves for a gradation with an average particle size (d50) of 125 microns ( $\mu\text{m}$ ). For some regulatory environments, CDS systems can also be designed to achieve an 80% annual solids load reduction based on an average particle size (d50) of 75 microns ( $\mu\text{m}$ ) or 50 microns ( $\mu\text{m}$ ).

### Water Quality Flow Rate Method

In some cases, regulations require that a specific treatment rate, often referred to as the water quality design flow (WQQ), be treated. This WQQ represents the peak flow rate from either an event with a specific recurrence interval, e.g. the six-month storm, or a water quality depth, e.g. 1/2-inch (13 mm) of rainfall.

The CDS is designed to treat all flows up to the WQQ. At influent rates higher than the WQQ, the diversion weir will direct most flow exceeding the WQQ around the separation chamber. This allows removal efficiency to remain relatively constant in the separation chamber and eliminates the risk of washout during bypass flows regardless of influent flow rates.

Treatment flow rates are defined as the rate at which the CDS will remove a specific gradation of sediment at a specific removal efficiency. Therefore the treatment flow rate is variable, based on the gradation and removal efficiency specified by the design engineer.

### Rational Rainfall Method™

Differences in local climate, topography and scale make every site hydraulically unique. It is important to take these factors into consideration when estimating the long-term performance of any stormwater treatment system. The Rational Rainfall Method combines site-specific information with laboratory generated performance data, and local historical precipitation records to estimate removal efficiencies as accurately as possible.

Short duration rain gauge records from across the United States and Canada were analyzed to determine the percent of the total annual rainfall that fell at a range of intensities. US stations' depths were totaled every 15 minutes, or hourly, and recorded in 0.01-inch increments. Depths were recorded hourly with 1-mm resolution at Canadian stations. One trend was consistent at all sites; the vast majority of precipitation fell at low intensities and high intensity storms contributed relatively little to the total annual depth.

These intensities, along with the total drainage area and runoff coefficient for each specific site, are translated into flow rates using the Rational Rainfall Method. Since most sites are relatively small and highly impervious, the Rational Rainfall Method is appropriate. Based on the runoff flow rates calculated for each intensity, operating rates within a proposed CDS system are

determined. Performance efficiency curve determined from full scale laboratory tests on defined sediment PSDs is applied to calculate solids removal efficiency. The relative removal efficiency at each operating rate is added to produce a net annual pollutant removal efficiency estimate.

### Probabilistic Rational Method

The Probabilistic Rational Method is a sizing program Contech developed to estimate a net annual sediment load reduction for a particular CDS model based on site size, site runoff coefficient, regional rainfall intensity distribution, and anticipated pollutant characteristics.

The Probabilistic Method is an extension of the Rational Method used to estimate peak discharge rates generated by storm events of varying statistical return frequencies (e.g. 2-year storm event). Under the Rational Method, an adjustment factor is used to adjust the runoff coefficient estimated for the 10-year event, correlating a known hydrologic parameter with the target storm event. The rainfall intensities vary depending on the return frequency of the storm event under consideration. In general, these two frequency dependent parameters (rainfall intensity and runoff coefficient) increase as the return frequency increases while the drainage area remains constant.

These intensities, along with the total drainage area and runoff coefficient for each specific site, are translated into flow rates using the Rational Method. Since most sites are relatively small and highly impervious, the Rational Method is appropriate. Based on the runoff flow rates calculated for each intensity, operating rates within a proposed CDS are determined. Performance efficiency curve on defined sediment PSDs is applied to calculate solids removal efficiency. The relative removal efficiency at each operating rate is added to produce a net annual pollutant removal efficiency estimate.

### Treatment Flow Rate

The inlet throat area is sized to ensure that the WQQ passes through the separation chamber at a water surface elevation equal to the crest of the diversion weir. The diversion weir bypasses excessive flows around the separation chamber, thus preventing re-suspension or re-entrainment of previously captured particles.

### Hydraulic Capacity

The hydraulic capacity of a CDS system is determined by the length and height of the diversion weir and by the maximum allowable head in the system. Typical configurations allow hydraulic capacities of up to ten times the treatment flow rate. The crest of the diversion weir may be lowered and the inlet throat may be widened to increase the capacity of the system at a given water surface elevation. The unit is designed to meet project specific hydraulic requirements.

## Performance

### Full-Scale Laboratory Test Results

A full-scale CDS system (Model CDS2020-5B) was tested at the facility of University of Florida, Gainesville, FL. This CDS unit was evaluated under controlled laboratory conditions of influent flow rate and addition of sediment.

Two different gradations of silica sand material (UF Sediment & OK-110) were used in the CDS performance evaluation. The particle size distributions (PSDs) of the test materials were analyzed using standard method "Gradation ASTM D-422 "Standard Test Method for Particle-Size Analysis of Soils" by a certified laboratory.

UF Sediment is a mixture of three different products produced by the U.S. Silica Company: "Sil-Co-Sil 106", "#1 DRY" and "20/40 Oil Frac". Particle size distribution analysis shows that the UF Sediment has a very fine gradation ( $d_{50} = 20$  to  $30 \mu\text{m}$ ) covering a wide size range (Coefficient of Uniformity, C averaged at 10.6). In comparison with the hypothetical TSS gradation specified in the NJDEP (New Jersey Department of Environmental Protection) and NJCAT (New Jersey Corporation for Advanced Technology) protocol for lab testing, the UF Sediment covers a similar range of particle size but with a finer  $d_{50}$  ( $d_{50}$  for NJDEP is approximately  $50 \mu\text{m}$ ) (NJDEP, 2003).

The OK-110 silica sand is a commercial product of U.S. Silica Sand. The particle size distribution analysis of this material, also included in Figure 1, shows that 99.9% of the OK-110 sand is finer than 250 microns, with a mean particle size ( $d_{50}$ ) of 106 microns. The PSDs for the test material are shown in Figure 1.

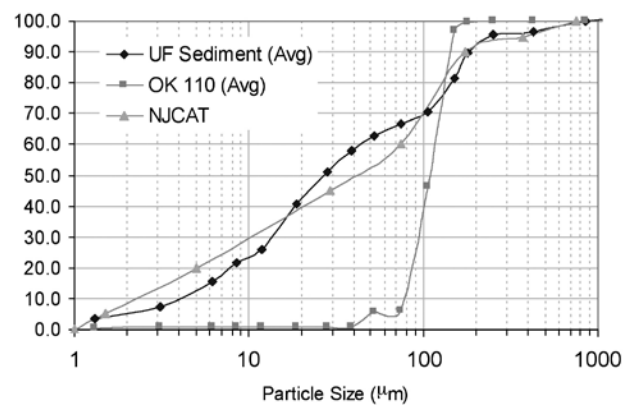

Figure 1. Particle size distributions

Tests were conducted to quantify the performance of a specific CDS unit (1.1 cfs (31.3-L/s) design capacity) at various flow rates, ranging from 1% up to 125% of the treatment design capacity of the unit, using the 2400 micron screen. All tests were conducted with controlled influent concentrations of approximately 200 mg/L. Effluent samples were taken at equal time intervals across the entire duration of each test run. These samples were then processed with a Dekaport Cone sample splitter to obtain representative sub-samples for Suspended Sediment Concentration (SSC) testing using ASTM D3977-97 "Standard Test Methods for Determining Sediment Concentration in Water Samples", and particle size distribution analysis.

## Results and Modeling

Based on the data from the University of Florida, a performance model was developed for the CDS system. A regression analysis was used to develop a fitting curve representative of the scattered data points at various design flow rates. This model, which demonstrated good agreement with the laboratory data, can then be used to predict CDS system performance with respect

to SSC removal for any particle size gradation, assuming the particles are inorganic sandy-silt. Figure 2 shows CDS predictive performance for two typical particle size gradations (NJCAT gradation and OK-110 sand) as a function of operating rate.

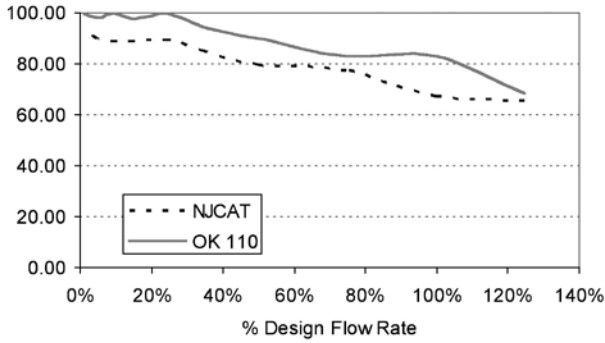

Figure 2. CDS stormwater treatment predictive performance for various particle gradations as a function of operating rate.

Many regulatory jurisdictions set a performance standard for hydrodynamic devices by stating that the devices shall be capable of achieving an 80% removal efficiency for particles having a mean particle size ( $d_{50}$ ) of 125 microns (e.g. Washington State Department of Ecology — WASDOE - 2008). The model can be used to calculate the expected performance of such a PSD (shown in Figure 3). The model indicates (Figure 4) that the CDS system with 2400 micron screen achieves approximately 80% removal at the design (100%) flow rate, for this particle size distribution ( $d_{50} = 125 \mu\text{m}$ ).

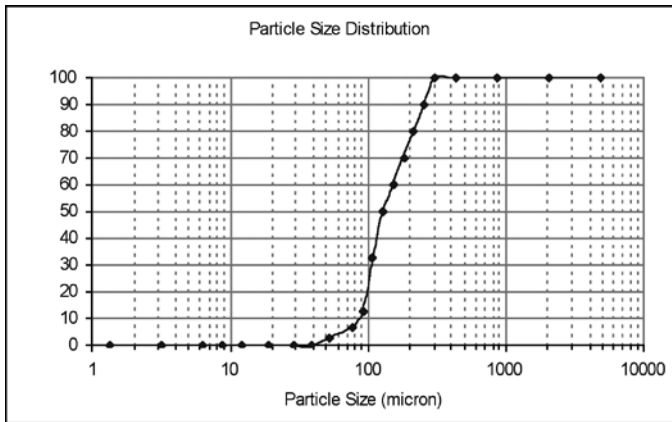

Figure 3. WASDOE PSD

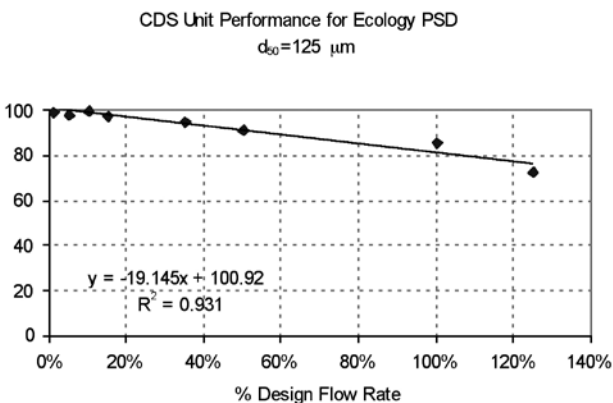

Figure 4. Modeled performance for WASDOE PSD.

## Maintenance

The CDS system should be inspected at regular intervals and maintained when necessary to ensure optimum performance. The rate at which the system collects pollutants will depend more heavily on site activities than the size of the unit. For example, unstable soils or heavy winter sanding will cause the grit chamber to fill more quickly but regular sweeping of paved surfaces will slow accumulation.

## Inspection

Inspection is the key to effective maintenance and is easily performed. Pollutant transport and deposition may vary from year to year and regular inspections will help ensure that the system is cleaned out at the appropriate time. At a minimum, inspections should be performed twice per year (e.g. spring and fall) however more frequent inspections may be necessary in climates where winter sanding operations may lead to rapid accumulations, or in equipment washdown areas. Installations should also be inspected more frequently where excessive amounts of trash are expected.

The visual inspection should ascertain that the system components are in working order and that there are no blockages or obstructions in the inlet and separation screen. The inspection should also quantify the accumulation of hydrocarbons, trash, and sediment in the system. Measuring pollutant accumulation can be done with a calibrated dipstick, tape measure or other measuring instrument. If absorbent material is used for enhanced removal of hydrocarbons, the level of discoloration of the sorbent material should also be identified



during inspection. It is useful and often required as part of an operating permit to keep a record of each inspection. A simple form for doing so is provided.

Access to the CDS unit is typically achieved through two manhole access covers. One opening allows for inspection and cleanout of the separation chamber (cylinder and screen) and isolated sump. The other allows for inspection and cleanout of sediment captured and retained outside the screen. For deep units, a single manhole access point would allow both sump cleanout and access outside the screen.

The CDS system should be cleaned when the level of sediment has reached 75% of capacity in the isolated sump or when an appreciable level of hydrocarbons and trash has accumulated. If absorbent material is used, it should be replaced when significant discoloration has occurred. Performance will not be impacted until 100% of the sump capacity is exceeded however it is recommended that the system be cleaned prior to that for easier removal of sediment. The level of sediment is easily determined by measuring from finished grade down to the top of the sediment pile. To avoid underestimating the level of sediment in the chamber, the measuring device must be lowered to the top of the sediment pile carefully. Particles at the top of the pile typically offer less resistance to the end of the rod than consolidated particles toward the bottom of the pile. Once this measurement is recorded, it should be compared to the as-built drawing for the unit to determine whether the height of the sediment pile off the bottom of the sump floor exceeds 75% of the total height of isolated sump.

## Cleaning

Cleaning of a CDS system should be done during dry weather conditions when no flow is entering the system. The use of a vacuum truck is generally the most effective and convenient method of removing pollutants from the system. Simply remove the manhole covers and insert the vacuum hose into the sump. The system should be completely drained down and the sump fully evacuated of sediment. The area outside the screen should also be cleaned out if pollutant build-up exists in this area.

In installations where the risk of petroleum spills is small, liquid contaminants may not accumulate as quickly as sediment. However, the system should be cleaned out immediately in the event of an oil or gasoline spill. Motor oil and other hydrocarbons that accumulate on a more routine basis should be removed when an appreciable layer has been captured. To remove these pollutants, it may be preferable to use absorbent pads since they are usually less expensive to dispose than the oil/water emulsion that may be created by vacuuming the oily layer. Trash and debris can be netted out to separate it from the other pollutants. The screen should be cleaned to ensure it is free of trash and debris.

Manhole covers should be securely seated following cleaning activities to prevent leakage of runoff into the system from above and also to ensure that proper safety precautions have been followed. Confined space entry procedures need to be followed if physical access is required. Disposal of all material removed from the CDS system should be done in accordance with local regulations. In many jurisdictions, disposal of the sediments may be handled in the same manner as the disposal of sediments removed from catch basins or deep sump manholes. Check your local regulations for specific requirements on disposal.



CDS Model	Diameter		Distance from Water Surface to Top of Sediment Pile		Sediment Storage Capacity	
	ft	m	ft	m	y <sup>3</sup>	m <sup>3</sup>
CDS1515	3	0.9	3.0	0.9	0.5	0.4
CDS2015	4	1.2	3.0	0.9	0.9	0.7
CDS2015	5	1.5	3.0	0.9	1.3	1.0
CDS2020	5	1.5	3.5	1.1	1.3	1.0
CDS2025	5	1.5	4.0	1.2	1.3	1.0
CDS3020	6	1.8	4.0	1.2	2.1	1.6
CDS3025	6	1.8	4.0	1.2	2.1	1.6
CDS3030	6	1.8	4.6	1.4	2.1	1.6
CDS3035	6	1.8	5.0	1.5	2.1	1.6
CDS4030	8	2.4	4.6	1.4	5.6	4.3
CDS4040	8	2.4	5.7	1.7	5.6	4.3
CDS4045	8	2.4	6.2	1.9	5.6	4.3
CDS5640	10	3.0	6.3	1.9	8.7	6.7
CDS5653	10	3.0	7.7	2.3	8.7	6.7
CDS5668	10	3.0	9.3	2.8	8.7	6.7
CDS5678	10	3.0	10.3	3.1	8.7	6.7

Table 1: CDS Maintenance Indicators and Sediment Storage Capacities

Note: To avoid underestimating the volume of sediment in the chamber, carefully lower the measuring device to the top of the sediment pile. Finer silty particles at the top of the pile may be more difficult to feel with a measuring stick. These finer particles typically offer less resistance to the end of the rod than larger particles toward the bottom of the pile.

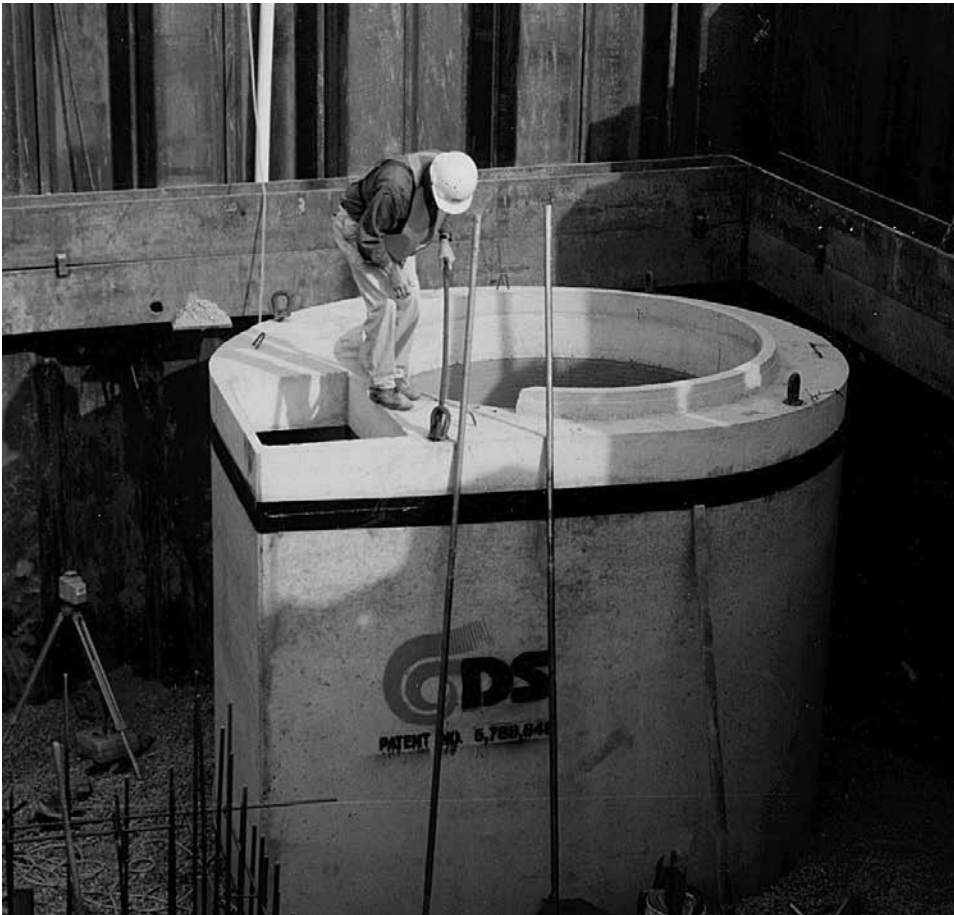



## SUPPORT

- Drawings and specifications are available at [www.ContechES.com](http://www.ContechES.com).
- Site-specific design support is available from our engineers.



800-338-1122

[www.ContechES.com](http://www.ContechES.com)

©2017 Contech Engineered Solutions LLC, a QUIKRETE Company

Contech Engineered Solutions provides site solutions for the civil engineering industry. Contech's portfolio includes bridges, drainage, sanitary sewer, earth stabilization and stormwater treatment products. For information on other Contech division offerings, visit [www.ContechES.com](http://www.ContechES.com) or call 800.338.1122

NOTHING IN THIS CATALOG SHOULD BE CONSTRUED AS A WARRANTY. APPLICATIONS SUGGESTED HEREIN ARE DESCRIBED ONLY TO HELP READERS MAKE THEIR OWN EVALUATIONS AND DECISIONS, AND ARE NEITHER GUARANTEES NOR WARRANTIES OF SUITABILITY FOR ANY APPLICATION. CONTECH MAKES NO WARRANTY WHATSOEVER, EXPRESS OR IMPLIED, RELATED TO THE APPLICATIONS, MATERIALS, COATINGS, OR PRODUCTS DISCUSSED HEREIN. ALL IMPLIED WARRANTIES OF MERCHANTABILITY AND ALL IMPLIED WARRANTIES OF FITNESS FOR ANY PARTICULAR PURPOSE ARE DISCLAIMED BY CONTECH. SEE CONTECH'S CONDITIONS OF SALE (AVAILABLE AT [WWW.CONTECHES.COM/COS](http://WWW.CONTECHES.COM/COS)) FOR MORE INFORMATION.

The product(s) described may be protected by one or more of the following US patents: 5,322,629; 5,624,576; 5,707,527; 5,759,415; 5,788,848; 5,985,157; 6,027,639; 6,350,374; 6,406,218; 6,641,720; 6,511,595; 6,649,048; 6,991,114; 6,998,038; 7,186,058; 7,296,692; 7,297,266; related foreign patents or other patents pending.